



April 13, 2017

Mr. Michael Surguine  
Sanctuary on Camelback Mountain Resort & Spa  
5700 East McDonald Drive  
Paradise Valley, Arizona 85253



**RE: Amendment No.2 to the Jade Bar Parking Analysis dated February 25, 2013 PLUS  
Partial Response to Statement of Direction from Town Council Regarding  
The Views Ballroom Expansion and Interstitial Bungalows**

Dear Mr. Surguine:

At the request of George Burton of the Town of Paradise Valley, CivTech has prepared this comprehensive letter to serve as Amendment No. 2 to the *Jade Bar at Sanctuary Camelback Mountain Parking Analysis* prepared by CivTech and dated February 25, 2013 as well as to provide partial responses to items discussed by Paradise Valley's Town Council in study sessions on February 9 and 23, 2017 and subsequently included in a Statement of Direction (SOD), a draft of which was reviewed by the Council at the former session, and approved at the latter session. The discussion centered on recent improvements proposed for the Sanctuary on Camelback Mountain Resort & Spa.

**BACKGROUND**

The Sanctuary site consists of two types of facilities in addition to the Main Resort. The Casitas are rental units that cannot be permanent residences. The Casas are privately-owned resort homes for individual families and guests for overnight accommodations; at an owner's request a Casa can be added to the resort rental pool. (Please note that these designations were taken directly from a report by Town staff and "Casitas" is used herein for consistency.) In this analysis, an addition of units proposed within the area in which the Casitas are located will be addressed.

The Sanctuary operated under Special Use Permit (SUP) stipulations of Town Ordinance Number 645 approved on April 12, 2012 and the stipulations approved on March 5, 2013 for a minor amendment of the SUP, a total of some 70 stipulations. The minor amendment application package approved in March 2013 included the Jade Bar parking analysis.

Amendment No. 1 to the parking analysis was finalized on August 29, 2014 after revision in response to comments received from the Town. That first amendment was requested to document the effect on parking of resort improvements proposed at that time and of any of the proposed modifications to several of the stipulations under which the resort operated. The Town consolidated all of the past stipulations and revisions to those stipulations, issuing two new SUPs (14-05 and 14-06) to replace those under which The Sanctuary had been operating. Amendment No. 1 addressed only those items that were considered parking-related, however remotely. It also allowed for four new guest units in a building that would replace a tennis court

**PROPOSED IMPROVEMENTS**

Since the first amendment was completed in 2014, an additional expansion of The Sanctuary has been proposed. The architect of the proposed improvements to the property has designated the improvements as "interstitial bungalows." Since the staff report noted above does not define the

term “bungalow” and the proposed bungalows are within the Casitas area, the Casitas and bungalows will be more-generically considered “rental units” for the purposes of this study. All are units that will be available for rent to hotel guests of The Sanctuary for purposes of this parking analysis.

The site plan provided to CivTech (see **Attachment 1**) shows that 39 1- and 2-floor bungalows will be constructed on the ends of or beneath the existing 41 Casitas. Two clusters of three more bungalows (6 total) will stand free among the Casitas, bringing the total number of new units to 45. Thus, the total number of rental units will be increased from the existing 41 Casitas to a total of 86 Casitas and bungalows. On-site guest units could increase to totals of 155 in the interim condition and 174 in the ultimate condition.

As part of the bungalow construction, one of the bungalow clusters will be constructed on the site of a small, existing swimming pool. This pool will be replaced by a new, larger pool elsewhere within the Casitas area. (The pool is considered an amenity that will not generate new vehicular trips or the need for parking spaces.)

The number of parking spaces for the Casitas-area rental units will be increased by 18 from the existing 79 spaces (including 1 ADA-compliant space) to 97 spaces. Overall on-site parking will increase to 368 in the interim condition and 391 in the ultimate condition.

Since Amendment No. 2 was drafted, additional improvements have been proposed. Including the above, the improvements now before Council include a 2,189-square foot (SF) expansion of The Views Ballroom. The architect indicated to CivTech that, per the International Building Code (an industry reference), the ballroom expansion would accommodate 146 additional guests at 15 SF per person.

### ***ADA COMPLIANCE***

The issue of compliance with the Americans with Disabilities Act of 1990 (ADA) in regard to the entire site and elsewhere was addressed in Amendment No. 1. Since the number of parking spaces is expected to increase, it will be addressed again here.

With respect to the rental units in the Casitas area, there is, as noted, one existing ADA space provided near Casita Unit 10 on the site plan. CivTech assumes that Unit 10 was either designed (or retrofitted) to be accessible under the *2010 ADA Standards for Accessible Design* and, therefore, an ADA-compliant space was provided for the unit.

In regard to the other rental units, Exception 2 of Section 216.5 of the 2010 ADA Standards indicates that, “In residential facilities, where parking spaces are assigned to specific residential dwelling units, identification of accessible parking spaces shall not be required.” Parking spaces are and will continue to be interspersed among the units to keep them close to the units and convenient for the occupants. From this it can be concluded that no other parking spaces identified as ADA-compliant are required for the new bungalows.

Another issue is whether The Sanctuary will continue to provide a sufficient number of ADA-compliant parking spaces with the addition of the bungalows. The original Jade Bar analysis and Amendment No. 1 indicated that there would be 369 permanent traditional parking spaces on site in what was then considered the ultimate condition. With the proposed addition of 18 parking spaces for the bungalows, the new ultimate total would be 387 parking spaces (369+18=387). The ADA standards indicate in Table 208.2 that a total of 8 ADA-compliant spaces is required at facilities that provide from 301 to 400 parking spaces. There are currently provided 8 ADA-compliant spaces on The Sanctuary property; thus, The Sanctuary will continue to provide a sufficient number of ADA-compliant parking spaces on the property with the addition of the 45 proposed bungalows.

**PARKING RATIO**

Upon completion of the project, there will be 86 rental units consisting of 41 existing Casitas and 45 new bungalows. With 18 new spaces added to the 79 existing spaces, a total of 97 parking spaces will be provided on the subject parcel. The resulting parking ratio is 1.13 parking spaces per rental unit or just over eight spaces for every seven rental units in this area of the resort. This ratio falls less than six percent short of a Town requirement that a minimum of 1.20 spaces be provided per each guest unit.

Overall, however, The Sanctuary will be well-parked, as will be demonstrated. In the interim and ultimate conditions, there will be 155 and 174 on-site guest units with 368 and 391 parking spaces provided, respectively. These yield ratios of 2.37 and 2.25 spaces per key or guest unit, nearly double the Town requirement of 1.20 spaces per key. **Table 1** is a summary of the parking for other resorts within the Town limits. A review of **Table 1** reveals that other resorts provide (or will provide) an average of fewer than two spaces per key; therefore, The Sanctuary will provide a sufficient number of parking spaces overall.

**Table 1 – Comparison of Parking Provided at Town Resorts**

<b>Resort</b>	<b>Size (Acres)</b>	<b>Guest Units</b>	<b>Other Facilities</b>	<b>Parking Provided</b>	<b>Spaces per Key</b>
Camelback Inn	117	453	Restaurant Conference Spa	1,157	2.55
Doubletree Paradise Valley	20	378	Retail Restaurant Ballroom Meeting Space	559 on-site 45 off-site	1.60
Montelucia	28	293	Retail Restaurant	610	2.08
Hermosa Inn	6.4	35	Restaurant Meeting Space	111	3.17
Renaissance Scottsdale Resort	22.75	171	Restaurant Meeting/Banquet Tennis Courts	230	1.35
Smoketree Resort	5	28	Restaurant Salon	74	2.64
Scottsdale Plaza	36.5	404	Restaurant Ballroom/Banquet Meeting Space	403	1.00
Ritz Carlton (Proposed)	110	200 / 320	Restaurant Ballroom/Banquet Meeting Space	460 / 700	2.30 / 2.19
<b>Average</b>	<b>43.2</b>	<b>254 / 260</b>		<b>456 / 486</b>	<b>1.80 / 1.87</b>
<b>The Sanctuary</b> Current / Ultimate <b>Proposed</b>	<b>53</b>	106 / 125 <b>155 / 174</b>	Restaurant Meeting Space Spa Tennis Courts	346 / 369 <b>368 / 391</b>	3.26 / 2.95 <b>2.37 / 2.25</b>

## **SHARED-PARKING ANALYSIS**

One of the tables in Appendix D of the approved 2013 parking analysis was a peak use shared parking analysis for the weekend condition, which was demonstrated in the study to require a higher number of shared parking spaces than the typical weekday condition. In Amendment No.1, Appendix D was updated to reflect The Sanctuary being permitted to allow the conference center, where large events could be hosted, to remain open longer in the evening. Since the changes affected only the hours after 10 PM and the highest number of parking spaces under the shared-use analysis was identified as being from 8 to 9 PM, the maximum number of shared parking spaces, 287 spaces, did not change. That shared-parking analysis was based in part on 125 rental units.

The 4 guest units noted in the 2014 amendment plus 45 proposed bungalows bring the rental unit total to 174 (125+4+45=174). **Attachment 2** is a revised version of Appendix D that was attached to Amendment No. 1 with the late-night hour changes incorporated into the table. *Please note that the only change necessary was the increase in the Resort Guest Rooms from 125 to 174 in the left-most column of facilities. As noted, the new pool is an amenity for Casitas-area guests and does not generate the need for new parking spaces.*

With respect to the expansion of The Views ballroom, CivTech reviewed its previous studies to determine if the expansion of The Views had been accounted for as a then-planned “future” improvement now being realized. CivTech did not find that the 2,189-SF ballroom expansion was envisioned before now; thus, the effect of this expansion on parking should also be considered on **Attachment 2** in order to provide a complete accounting of the proposed improvements and their effects. As can be seen on the attachment, the conference floor area has been increased by 2,189 from 6,211 SF to 8,400 SF.

A review of **Attachment 2** reveals that the addition of 45 new bungalows and a 2,189 SF expansion of The Views ballroom would increase the maximum need for parking spaces on The Sanctuary property to 371 spaces, a net increase of 84 spaces from the reported maximum of 287 under prior shared-parking analyses. The need would be greatest from 8 to 9 PM on a weekend. With a new expected total of 391 spaces on the property, there will still be sufficient parking spaces at The Sanctuary to accommodate the parking needs of the proposed bungalows ballroom expansion and no additional parking is warranted beyond any planned new spaces.

## **TOTAL APPROVED PARKING AND SHARED PARKING**

As noted in the introductory paragraph, a reviewer for the Town of Paradise Valley commented that this amendment “should address total approved parking and shared parking.” This section has been added to do that for two parking conditions, an Interim Condition and an Ultimate Condition. Both will be described below in this brief summary of CivTech efforts to date.

In February 2013, CivTech prepared the *Jade Bar at the Sanctuary Resort Parking Analysis*. In this study CivTech evaluated two parking conditions:

1. **Interim Condition**, described on Page 1 as “the number of parking spaces required to support the interim condition of the Resort with an expansion to the Jade Bar.”
2. **Ultimate Condition**, described on Page 1 a future condition “which includes the addition of guest rooms and spa area...20 additional guest rooms (Spa Suites) and the 1,350 square feet of additional spa area (Spa Pavilion)...[T]he tennis courts will be removed and the lower level parking will be reconfigured[, ] provid[ing] more parking than currently exists today.”

On page 8, CivTech noted that, in the Interim Condition, “The site plan shows 346 parking spaces available for sharing in the main parking areas.” Also on that page, CivTech noted that, in the Ultimate Condition, “369 parking spaces will be available for sharing in the main parking areas.”

In Table 6 of the 2013 parking analysis, the peak demand for the Ultimate Condition was estimated at 276 shared parking spaces on a weekday during the peak season and at 287 on a weekend during the peak season. These are all as noted by the reviewer. On page 6 of the original study, the Non-Shared peak season parking spaces, that is, the number of spaces required by Code, are 320 for the Interim Condition and 345 for the Ultimate Condition. Thus, The Sanctuary provides a comfortable number of spaces more than is required by the shared parking analysis.

Appendix D of Amendment No. 1, the “Casa 2” amendment (as described by the reviewer) was prepared in August 2014 for the Ultimate Condition. This amendment shows a requirement for the same 287 shared parking spaces needed with 346 shared parking spaces available. These are the same as documented in the 2013 parking analysis. The renovations to the Casa del Sano, which converted garages into bedrooms warranted the addition of four new parking spaces; thus, the non-shared total increased by four spaces to 349 from the 345 documented in 2013.

As the reviewer noted, the site plan attached to the first submittal of this Amendment No. 2 clearly showed a net increase of 17 parking spaces, which is corrected herein to 18 new spaces. This fact was noted in the first submittal of the amendment and continues to be noted herein on page 2, in the sentence just before the “ADA Compliance” section.

**Table 2** summarizes the progression of the parking space counts from those documented in the approved 2013 parking analysis through this second submittal of Amendment No. 2.

**Table 2 – Resort Parking Summary**

Source	Phase	Parking Required		Parking Provided			Guest Keys	Spaces Per Key*	
		Per Code	Shared	Traditional		Valet Assist*			
				Prior	Added				Revised
<i>Jade Bar at the Sanctuary Camelback Mountain Parking Analysis (2013)</i>									
	Interim <sup>†</sup>	320	267			346	398	106	3.26
	Ultimate <sup>‡</sup>	345	287			369	424	125	2.95
<i>Amendment No. 1 (2014) – Casa del Sano Renovations</i>									
	Interim	325	272	346	+4	350	402	110	3.18
	Ultimate	350	292	369	+4	373	429	129	3.32
<i>Amendment No. 2 (2016) – Interstitial Bungalows and The Views ballroom Expansion</i>									
	Interim	380	351	350	+18	368	423	155	2.37
	Ultimate	404	371	373	+18	391	450	174	2.25

\* – Valet Assist is a yield approximately fifteen percent above “provided” spaces as documented in 2013 Jade Bar study and elsewhere by CivTech.

\* – Spaces per key calculated using “provided” [revised] traditional spaces divided by number of keys (i.e., guest units).

† – Interim Condition: “the number of parking spaces required to support the interim condition of the Resort with an expansion to the Jade Bar.”

‡ – Ultimate Condition: a future condition “which includes the addition of guest rooms and spa area...20 additional guest rooms (Spa Suites) and the 1,350 square feet of additional spa area (Spa Pavilion).”

**SOD ISSUES**

The SOD provides a list of five issues to be discussed. As many as three may be linked to traffic engineering and parking: the other two are in regard to the locations of utilities and architectural renderings. The primary one that will be addressed below is that “Traffic and circulation shall be studied.” In addition, in order to make certain that all of the councilmembers traffic-related concerns are addressed herein, CivTech reviewed the Town’s archived video footage of the two sessions. Before addressing the primary issue, in order to demonstrate that CivTech did consider all of the potential issues, CivTech will briefly address the other two, which are only remotely related to traffic engineering and on-site parking.

Item 1. “The applicant must identify the location of on-site retention basins and how this may affect parking and circulation.” The video footage showed that the councilmember was concerned how additional run off from any new impervious surfaces (parking areas, etc.) would affect cart paths, how the patterns of run off might be affected, etc.

*Response:* As traffic engineers, CivTech’s specialty is not expert in the area of drainage, a specific discipline within the broader category of civil engineering. CivTech presumes that a drainage engineer will provide the necessary calculations required by the Council. CivTech does suggest another, quick way to look at the issue. The existing lot coverage documented in the SOD is 19.1 percent. It will increase to 20.5 percent, an increase of 1.4 percentage points. Since 1.4 percent is 7.3 percent of the base lot coverage of 19.1 percent, it can be estimated that runoff across the property would average 7.3 percent (or  $\frac{1}{14}^{\text{th}}$ ) higher wherever there is runoff. If the runoff is 1 inch, it would increase to 1.07 inches, not an appreciably noticeable difference to motorized vehicles or pedestrians.

Item 2. “The hours of operation of the snack bar and pool area shall be reviewed.”

*Response:* The snack bar and pool are non-trip and parking-space generating amenities for residents and guests. Therefore, neither affects the previous parking analysis.

Other Issues. In the videos of the study sessions, CivTech heard councilmembers specifically express concerns about these other following issues, which will be addressed in the discussion that follows on traffic, parking, and circulation:

- How the improvements will affect “parking and circulation.”
- The improvements’ impacts on the sole site access at McDonald Drive (which is more-accurately described as the Town’s intersection of Superstition Lane, which is a public street south to Starlight Way, and McDonald Drive) the impact of additional site traffic along McDonald Drive.
- The staff parking seems to one councilmember to be always full now. Will the new interstitial bungalows require more staff and, if so, where will those new staff members park?
- How do ride-sourcing services such as Uber, Lyft, and Sidecar (the three largest of such services) affect trip generation?

### ***TRAFFIC, PARKING, AND CIRCULATION***

In order to respond to several of the issues raised above, a first step would be to estimate the number of trips generated by the improvements. Before doing so, it should be noted that the trip generation data used by CivTech were published in 2012. These are published in the 9<sup>th</sup> Edition of the Institute of Transportation Engineers’ (ITE) *Trip Generation Manual*. This was before the cell phone-facilitated phenomenon known as “ride-sourcing services” operated by “transportation network companies” (TNCs) had manifested itself to the degree it has since in American society.

Uber, founded in 2009, is the only one of the largest three companies operating such services (the others are Sidecar, founded in 2011, and Lyft, founded in 2012) to have been around long enough to have had any possible effect on the traffic data recorded for and submitted to the ITE for inclusion in the 2012 manual that CivTech uses. And, CivTech would point out, this effect would be minimal since new data is simply aggregated with long-standing data recorded before such services, some of which could have been recorded decades before. Therefore, before the trips generated are calculated, CivTech will begin by addressing the council-identified issue of what has been dubbed the “Uber effect.”

### **Uber Effect**

To understand the Uber effect, CivTech first conducted some on-line research to determine if there have been any studies that have measured the Uber effect. (The details of the technology, how it works, etc., are not important here.) Per a 2015 Masters' Thesis, demand for ride-sourcing services "has spread rapidly and become more important in urban transport [because] Companies such as Uber and Lyft may provide better service with less waiting time and higher vehicle occupancy when compared to traditional transportation services such as private auto, public transit and taxis." (Chen, Zhen, *Impact of Ride-Sourcing Services on Travel Habits and Transportation Planning*, University of Pittsburgh, 2015.) In fact, another degree candidate, in her thesis, "predict[ed] that at current conditions, TNCs such as Uber and Lyft will overtake taxi services. Thus, the taxi industry must focus on increasing TNC regulation, creating innovative technology, and modifying its service to appeal to consumers." (Wang, Alice, *The Economic Impact of Transportation Network Companies on the Taxi Industry*, Scripps College, April 2015.)

But has the so-called Uber effect been measured yet? The authors of *Factors Affecting Passenger Travel Demand In The United States: A White Paper from the National Center for Sustainable Transportation*, a study published in draft form in November 2015, indicate on page 6 that "new *shared mobility* options, such as...on-demand ride services (e.g. Uber) may also impact the current trends...However, new mobility options are a recent phenomenon: most of their impacts on travel demand and mode choice are expected to happen in future years" [Circella, et al., 2015. Emphasis in original.]

Although each of these studies cites several other studies, the focus of such studies tend away from asking the specific questions to which the councilmembers would like answers. Rather than focusing on how trips to a resort might be affected by use of these services, the research topics are much larger: will total vehicle miles traveled (VMT) each day in a particular urban area be reduced by the use of such services, will they affect the use of public transit, etc.

The consensus in early 2017 seems to be that ride-sourcing services have not yet reached peak usage and that they could eventually replace taxi services if taxi service providers do not become more competitive, convenient, etc. And, even as ride-sourcing increases the effect could be that it simply replaces taxi rides among a certain, generally-younger tech-savvy segment of the population, growing in use as that population grows.

For The Sanctuary, as long as the percentage of out-of-area guests not renting vehicles remains essentially the same as it is now, there would be little or no net effect on trip generation since these ride-sourcing services such as Uber, Lyft, and Sidecar operate similarly to taxi cabs with each ride to or from the site requiring two trips (one in, one out) and no permanent parking spaces required. Vehicles rented by guests arriving at an airport result in only half as many trips while requiring a parking space: one trip in upon arriving, a parking space while the vehicles is on-site, and one trip out when leaving the site (for a meal, sightseeing, or after checkout).

### **Employee Parking**

The comment regarding employee parking originated with a councilmember who lives in the area and frequently walks along McDonald Drive past the site. The councilmember noted that the lot often appears to be full and wondered out loud if it could accommodate additional employee vehicles. CivTech concurs that an additional 45 rooms would likely require the hiring of additional staff to clean the rooms and serve in various capacities the additional guests. CivTech is not equipped to address this issue and must defer to the property owner/manager in regard to the availability of sufficient employee parking.

**Traffic**

With respect to the traffic effects of the proposed improvements, the ITE *Trip Generation Manual* provides sufficient data to estimate the number of trips per day and per peak hour generated by the 45 new guest units. However, the increase in floor area of the ballroom is not specifically addressed, as ballrooms are ancillary to the hotel. Hence, the trip generation table is a hybrid that calculates trips generated by the rooms and estimates trips for the additional ballroom based on the additional parking spaces required to accommodate the additional 146 guests, which, as indicated above, is 39\* spaces. It is possible for two (or more, potentially) separate events, events that require the entire ballroom, to be scheduled in that ballroom in a day, so CivTech estimated trips for two events, an all-day corporate-type event and an evening affair. In this way, the PM peak hour could have trips both leaving arriving and arriving, the most conservative of all potential trips generation scenarios for the ballroom. In addition, there is no weekday trip generation rate for resort hotel rooms, so an estimated rate was used to calculate the average daily total (ADT) only. **Table 1** is the detailed trip generation for the proposed improvements.

**Table 3 – Trip Generation**

Land Use	ITE LUC	ITE Land Use Name	Quantity Units	AM Distribution		PM Distribution	
				In	Out	In	Out
Interstitial Bungalows	330	Resort Hotel	34 Rooms	72%	28%	43%	57%
The Views Ballroom Expansion	n/a	n/a	2,189† KSF*	100%	0%	50%	50%

Land Use	ADT		AM Peak Hour			PM Peak Hour				
	Avg. Rate	Total	Avg. Rate	In	Out	Total	Avg. Rate	In	Out	Total
Interstitial Bungalows	8.00‡	360	0.52‡	17	7	24	0.42	8	11	19
The Views Ballroom Expansion		78		39	0	39		39	39	78
<b>Totals</b>		<b>438</b>		<b>56</b>	<b>7</b>	<b>63</b>		<b>47</b>	<b>50</b>	<b>97</b>

\* KSF = 1,000 Square Feet  
 † Floor area shown is gross floor area of ballroom expansion only.  
 ‡ Daily rate not published; value is estimated

\*Note: Average rates were calculated by generating trips using equations for and dividing by total number of dwelling units. (See below.)

<b>CALCULATIONS (Equations shown only where available)</b>			
<b>Land Use [Units]</b>	<b>Daily</b>	<b>AM Peak Hour</b>	<b>PM Peak Hour</b>
Resort Hotel	Not available.	$T_{AM} = 45 \times 0.35 + 7.42 = 24$	Not available.

A review of the trip generation detailed in **Table 1** reveals that the proposed 45 interstitial bungalows and the 2,189-SF expansion of The Views ballroom are expected to generate fewer than 450 trips per day with 63 occurring during the AM peak hour (56 in/7 out) and 97 occurring during the PM peak hour (47 in/50 out).

*Impact of Site Traffic on Superstition Lane/McDonald Drive Intersection and on McDonald Drive.* Since The Sanctuary has but one site access, councilmembers expressed concern about the impact of these additional trips on the intersection of the site driveway with McDonald Drive. The related impact of the additional trips on McDonald drive in general were also questioned. First the issue of the classification of McDonald Drive needs to be addressed.

\* The total of 39 assumes ten percent of those attending events in the ballroom/conference area are resort guests. While the number of spaces required for just the expansion area calculates to more than 43, when aggregated with the existing conference area, the actual increase is just 43, ninety percent of which is 39 spaces.



*Classification of McDonald Drive.* During a council study sessions, one of the councilmembers was heard to remark that McDonald Drive is a “residential street.” Unfortunately, that is not the case in terms of how it functions. In chapter 4 of the ITE book, *Transportation and Land Development*, the authors describe how “Local streets serve to provide land access...Movement on local streets is incidental and involves traveling to or from a collector facility. Therefore, the trip length on the local street is short.” A collector facility “provides both land access and movement within residential...areas. Collectors penetrate, but should not have continuity through, residential areas.” The ITE’s *Guidelines for Residential Subdivision Street Design*, adds that “Collector streets have the primary purpose of intercepting traffic from intersecting local streets and carrying this movement to the nearest major streets. A secondary function is service to abutting land use.” [All emphasis in the original.] The *Guidelines* also add for local streets that “morning peak hour traffic [is] about 7 percent to 8 percent and afternoon peak hour traffic about 10 percent of ADT [Average Daily Traffic].” The Maricopa County Department of Transportation *MCDOT Roadway Design Manual* indicates that Major Collector roadways (collector roadways longer than one-half mile) can be expected to carry up to 8,500 vehicles per day (vpd) with just a single through lane in each direction. (It should be noted that the presence of a continuous two-way left turn lane and/or raised medians, both of which can be found along McDonald Drive, tends to allow some additional capacity as left-turning vehicles have a refuge in which they can safely wait to turn, thus not delaying vehicles traveling through and increasing the capacity in this manner.) Therefore, because McDonald Drive is longer than one-half mile and it carries traffic from the several residential streets intersecting it to major streets on either end (Scottsdale Road, Tatum Boulevard), McDonald Drive functions not only as a collector road, it should be considered to be a Major Collector roadway. The next section addresses existing traffic volumes on McDonald Drive.

*Existing McDonald Drive Traffic Volumes.* As noted above, as a Major Collector street, McDonald Drive could be expected to carry traffic volumes of 8,500 vpd. The Town recorded peak hour turning movements during three peak periods (AM, midday, and PM) at several intersections in early 2014 and made those available on-line. One of those intersections was Tatum Boulevard at McDonald Drive. In 2015, in conjunction with its traffic study for the new Ritz-Carlton resort now under construction at Mockingbird Lane and McDonald Drive, CivTech recorded AM and PM peak hour turning movement counts on McDonald Drive at Scottsdale Road and at Mockingbird Lane. The total eastbound and westbound movements approaching and/or departing these intersections are summarized in **Table 2**. Daily volumes can be estimated from the AM and Pm peak hour counts by dividing the hourly segment volume by the percentage-of-daily factors cited above, 8 percent for AM and 10 percent for PM. Copies of the traffic counts can be found as **Attachment 3**.

**Table 4 – Traffic Volumes**

Intersection <i>McDonald Drive at:</i>	Peak Period (Factor)	Volume East of Intersection EB/WB/Total (vph)	Volume West of Intersection EB/WB/Total (vph)	Estimated 2-Way ADT (vpd)
Scottsdale Road	AM (8%)	---	379 / 445 / 824	10,300
	PM (10%)	---	315 / 330 / 645	6,450
Mockingbird Lane	AM (8%)	---	271 / 338 / 609	7,615
	AM (8%)	296 / 319 / 615	---	7,690
	PM (10%)	---	261 / 333 / 594	5,940
Tatum Boulevard	PM (10%)	256 / 329 / 585	---	5,850
	AM (8%)	254 / 229 / 483	---	6,040
	PM (10%)	266 / 263 / 529	---	5,290

Since the Town did not report any roadway segment volumes, that is, volumes recorded over the course of a day or more, CivTech added a column to **Table 2**. The column is an estimate of daily volumes (ADTs) based on segment volumes during the peak hours and are calculated by dividing the hourly volume by either eight percent (AM) or ten percent (PM). A review of these results tends to show that the weekday volumes along McDonald Drive may be between 5,300 vpd and 7,700 vpd between Tatum Boulevard and Mockingbird Lane. (Please note that the substantially higher volumes immediately west of Scottsdale Road can be ascribed to the high-trip generating retail and office uses on both western corners of the intersection. To provide the capacity necessary for these trips, the City of Scottsdale has added several more lanes on the eastbound McDonald Drive approach to Scottsdale Road.) If the existing volumes on McDonald Drive are between 6,000 and 8,000 vpd as estimated, there is sufficient capacity to accommodate the additional weekday trips anticipated from the proposed expansion of The Sanctuary.

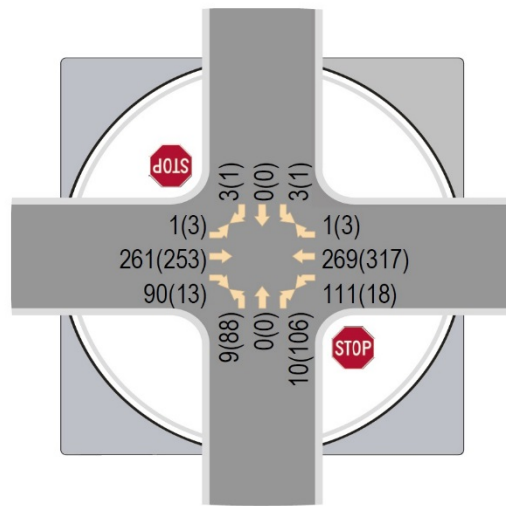

Superstition Ln/Nauni Vly Dr @ McDonald Dr

**Figure 1 – Estimated AM (PM) Turning Movements**

*Impact on Superstition Lane/McDonald Drive Intersection.* CivTech was not able to record turning movement volumes at intersection of Superstition Lane at McDonald Drive in the time allotted to prepare this study. In order to keep the approval process moving forward, for purposes of this study CivTech used eastbound and westbound traffic volumes on McDonald Drive from **Table 2** to simulate McDonald Drive approach volumes, volumes that include existing site driveway traffic as well as trips generated by some of The Sanctuary’s neighbors to the east and the Nauni Valley neighborhood on the north side of McDonald Drive. (Nauni Valley Drive, a private road that serves the neighborhood, intersects McDonald Drive across from Superstition Lane.) The volumes were “balanced,” that is, adjusted to show the number of vehicles entering intersection as the number leaving the intersection. The balancing added trips to several of the through movements; none of the recorded through movements was reduced, resulting in a conservative analysis.

CivTech estimated the number of site trips generated by The Sanctuary’s existing facilities and added to these estimates the trips anticipated during peak hours. For the ballroom, for example, since all of the new total of 152 parking spaces (113 existing, all of which would be in the existing traffic volumes on McDonald Drive, plus 39 new) would be needed just before an all-day event that begins at 9 AM, 152 trips would be considered as entering from 8-9 AM, just as those same 152 trips would be considered to be exiting from 5-6 PM after the event. Trips for the new total of 174 guest units were estimated using the same trip generation rates or equations as found in **Table 1**.

**Table 5 – Intersection Level of Service Criteria**

Level of Service	Control Delay (sec/veh)	
	Signalized	Unsignalized
A	≤ 10	≤ 10
B	> 10-20	> 10-15
C	> 20-35	> 15-25
D	> 35-55	> 25-35
E	> 55-80	> 35-50
F*	> 80	> 50

Source: Exhibit 18-4 and Exhibit 19-1, Highway Capacity Manual 2010

\* In addition, any movement that operates with a volume-to-capacity ratio greater than 1 (V:C>1), is considered to be operating at LOS F, no matter the control delay.

unsignalized intersections: LOS A represents the best operating conditions and LOS F the worst. Please note that levels of service are not calculated for uncontrolled and/or unopposed movements, such as through movements and right turns. Levels of service are calculated for left turn movements because they are opposed and a driver could be delayed by opposing through traffic.

**Table 4** summarizes the preliminary intersection level-of-service analysis for the intersection using the volumes in **Figure 1**. **Attachment 4** contains both printouts from the Synchro traffic analysis software, which uses the analysis methodology outlined in the latest (2010) edition of the *Highway Capacity Manual* for a two-way stop-controlled (TWSC) intersection. A review of the results summarized in **Table 3**, reveals that, with conservative estimated turning movement volumes, the intersection stop-controlled northbound Superstition Lane and southbound Nauri Valley Drive approaches to McDonald Drive should operate at acceptable levels of service of not less than LOS C with an average control delay of not more than 17.1 seconds per vehicle.

**Circulation**

The final issue to be addressed is on-site circulation. CivTech does not anticipate any on-site circulation issues with the addition of perhaps 100 total trips in either peak hour for several reasons. These trips represent, on average, fewer than one new trip per minute in either direction of the internal roadway network, trips that are further diluted as they travel via various routes to different destinations on-site. Also, CivTech previously documented that, if necessary, The Sanctuary would employ valets to park vehicles. The use of valets not only allows a greater density of parking, it provides a greater consistency of travel throughout the site as the valets are generally more familiar with the site than infrequent guests and with each other's driving habits. The few neighbors that live along Starlight Way that may use Superstition Lane, if they are aware of large events at The Sanctuary, have alternate routes to McDonald Drive (Dragoon Lane and Cameldale Way) and, therefore, should not be inconvenienced by traffic for such an event.

**Figure 1** shows CivTech's estimated future AM and PM peak hour turning movement volumes at the intersection of Superstition Lane/Nauri Valley Drive and McDonald Drive. CivTech conducted a (very) preliminary intersection level-of-service analysis for the intersection. The concept of level of service (LOS) uses qualitative measures that characterize operational conditions within the traffic stream. The analysis considers factors that include speed, travel time, freedom to maneuver, traffic interruptions, and comfort and convenience. At intersections, levels of service are defined within ranges of "average control delay per vehicle," that is, the number of seconds a vehicle can expect to wait due to the presence of a traffic control device. For reference, **Table 3** lists the level of service criteria for signalized and

**Table 6 – TWSC LOS Analysis Summary Superstition Lane & McDonald Drive**

Movement	AM LOS (delay)	PM LOS (delay)
NB Shared (Stop)	C (15.1 sec)	C (17.1 sec)
SB Shared (Stop)	B (14.9 sec)	B (14.0 sec)
EB Left	A (7.8 sec)	A (8.0 sec)
WB Left	A (8.4 sec)	A (7.9 sec)

**Attachment 5** is a graphic showing existing traffic volumes along McDonald Drive, those expected to be generated by the proposed changes to The Sanctuary, and the capacity of the roadway segments.

### **CONCLUSIONS AND RECOMMENDATIONS**

An addition of 45 bungalows and a 2,189-SF expansion of The Views ballroom are being proposed for The Sanctuary on Camelback Mountain Resort & Spa. The bungalows will be located within the area in which The Sanctuary's 41 rental Casita units are located. One free-standing cluster of three bungalows will be constructed on the site of a small existing swimming pool. The small pool will be replaced by a larger pool elsewhere in the casitas area. To accommodate the guests that rent the additional units, 17 new parking spaces will be provided. This document has been drafted to serve two purposes: as Amendment No. 2 to CivTech's February 2013 Jade Bar parking analysis for the resort to assess the effects of the proposed bungalows on parking at The Sanctuary and as a partial response to several issues raised by the Town Council (and documented in a Statement of Direction approved February 23, 2017) regarding traffic, parking, and circulation not addressed in previous studies or amendments to those studies.

From the foregoing, the following can be concluded:

- No other parking spaces identified as ADA-compliant are required for the new bungalows.
- With 8 ADA-compliant spaces of a new total of 386 traditional parking spaces provided on site, The Sanctuary will continue to provide a sufficient number of ADA-compliant parking spaces on the property with the addition of the 45 proposed bungalows.
- The Sanctuary will be well-parked: in the interim and ultimate conditions, there will be 155 and 174 on-site guest units with 368 and 391 parking spaces provided, respectively. These yield ratios of 2.37 and 2.25 spaces per key or guest unit, nearly double the Town requirement of 1.20 spaces per key.
- For The Sanctuary, as long as the percentage of out-of-area guests not renting vehicles remains essentially the same as it is now, there would be little or no net effect on trip generation since ride-sourcing services such as Uber, Lyft, and Sidecar operate similarly to taxi cabs.
- The addition of 45 new bungalows and a 2,189-SF expansion of The Views ballroom would increase the maximum need for parking spaces on The Sanctuary property to 371 spaces, a net increase of 84 spaces from the reported maximum of 287 under prior shared-parking analyses. The need would be greatest from 8 to 9 PM on a weekend. With a new expected total of 391 spaces on the property, there will be sufficient parking spaces at The Sanctuary to accommodate its parking needs.
- The proposed 45 interstitial bungalows and the 2,189-SF expansion of The Views ballroom are expected to generate fewer than 450 trips per day with 63 occurring during the AM peak hour (56 in/7 out) and 97 occurring during the PM peak hour (47 in/50 out).
- If the existing volumes on McDonald Drive are between 5,300 and 7,700 vpd as estimated, there is sufficient capacity to accommodate the additional weekday trips anticipated from the proposed expansion of The Sanctuary.
- With conservative estimated turning movement volumes, the intersection stop-controlled northbound Superstition Lane and southbound Nauni Valley Drive approaches to McDonald Drive should operate at acceptable levels of service of not less than LOS C with an average control delay of not more than 17.1 seconds per vehicle..

- CivTech does not anticipate any on-site circulation issues with the addition of perhaps 100 total trips in either peak hour for several reasons documented in the study.

Thank you. If you have any questions or comments, please contact me at (480) 659-4250.

Sincerely,



Joseph F. Spadafino, P.E., PTOE, PTP  
Project Manager/Senior Traffic Engineer

Attachments (5)

1/9/2017 10:29:19 AM Copyright © 2017 | R. Nicholas Loope FAIA, LLC | All Rights Reserved This document is a work product of R. Nicholas Loope, FAIA, LLC. It is confidential and contains proprietary information and is the intellectual property of R. Nicholas Loope, FAIA, LLC. It is for the exclusive use of our client toward constructing the design on the specific site indicated. Any or all of the information contained herein may not be shared, sold, reproduced, repurposed or disclosed under any circumstances without the express written permission of R. Nicholas Loope, FAIA, LLC.

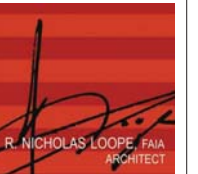

5070 N. 40th St., Suite 140  
 Phoenix AZ 85016

### PROJECT DATA

Site: 268,235 sf = 6.2 acres

<b>All Existing Units:</b> 41 total = 53,300 sf	
A Casitas	24 total = 31,200 sf
B Casitas	17 total = 22,100 sf
<b>All New Units:</b> 45 total = 20,666 sf (38.8%)	
Infill A	4 total = 2,296 sf
Infill B	6 total = 3,180 sf
B2 lock-outs	3 total = 2,550 sf
End Bungalows	23 total = 9,085 sf
Cluster Bungalows	9 total = 3,555 sf
<b>TOTAL UNITS</b>	<b>86 total = 73,966 sf</b>
<b>Total Parking:</b>	<b>97 spaces</b>
Existing Parking	79 spaces
Added Parking	18 spaces

NOTE: On-site stormwater retention will be provided for new additions/footprint.

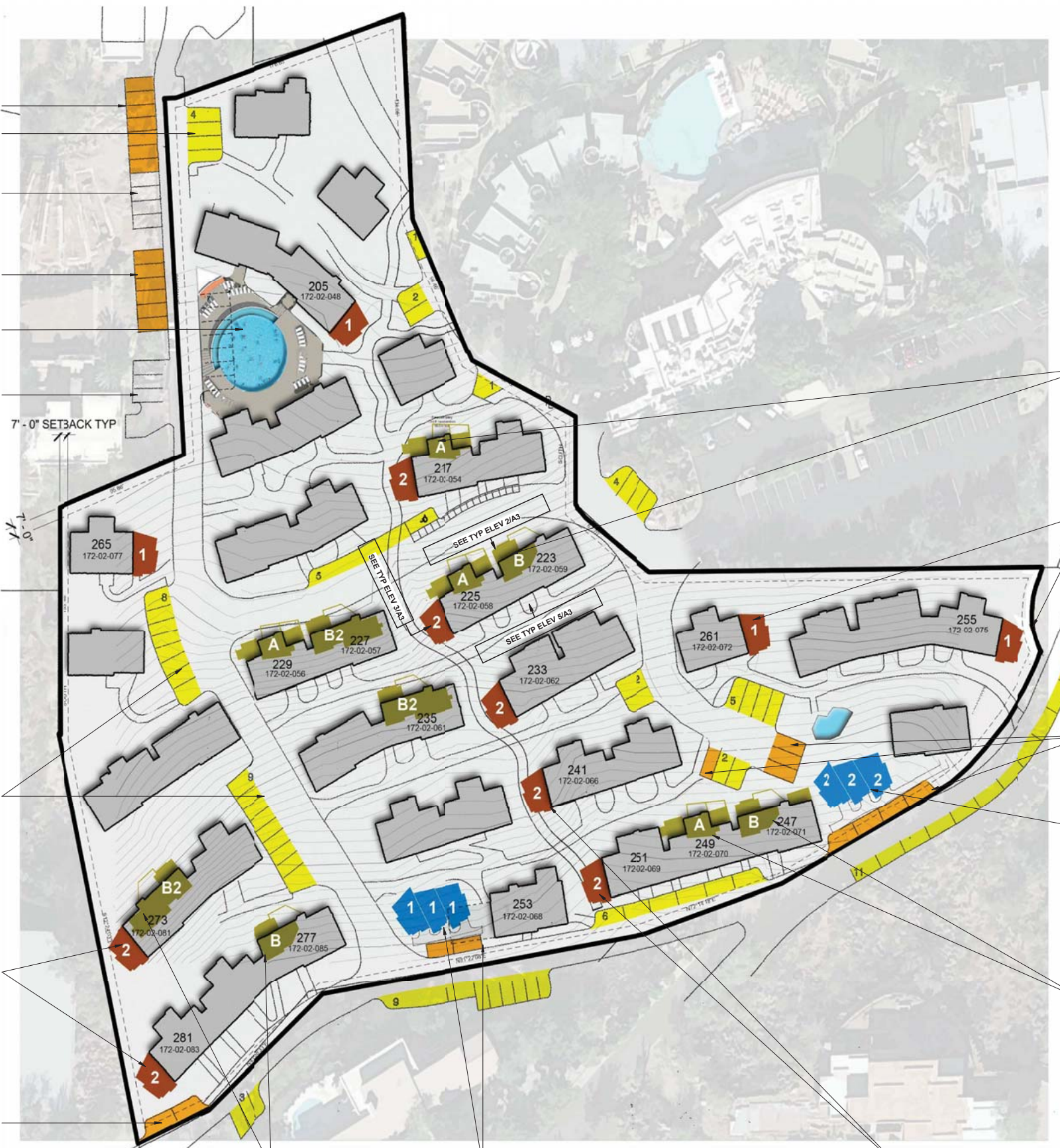

- 7 relocated parking spaces  
Existing parking Typ.
- Casa 2 parking not included
- 6 new parking spaces
- New Swimming Pool (see A4)  
7 parking spaces relocated
- Casa 2 parking not included

**LANDSCAPE NOTE**  
 NO NEW LANDSCAPE PLANTING WILL BE ADDED. AFFECTED SIGNIFICANT PLANTS AND TREES WITHIN CONSTRUCTION AREAS WILL BE RELOCATED NEARBY AND CLEAR OF NEW STRUCTURES. ANY PLANT LOST DURING CONSTRUCTION WILL BE REPLACED.

**SITE LIGHTING NOTE**  
 NEW STRUCTURES WILL NOT BE ILLUMINATED BY EXTERNAL SITE LIGHTING. THE ONLY EXTERIOR LIGHTING TO BE AT ENTRY/EGRESS DOORS AS REQUIRED, TO MATCH EXISTING LIGHTING AND COMPLIANT WITH DARK SKY ORDINANCES. PATHWAY AND GROUND LANDSCAPE LIGHTING WILL BE RELOCATED ONLY WHEN NECESSARY. ADDITIONAL PATH LIGHTING IS NOT ANTICIPATED. (SEE SHEET A4 FOR PHOTOS OF FIXTURES)

Infill Key under Existing Casita and Balcony

1-Story attached Bungalow Key adjacent to Existing Casita

Added Parking (8)

2-Story Freestanding Bungalow Keys Cluster

Infill Key under Existing Casita and Balcony

Existing Parking Typ.

2-Story attached Bungalow Keys adjacent to Existing Casita

Added Parking (2)

Infill Key under Existing Casita and Balcony

1-Story Freestanding Bungalow Keys Cluster & 2 new parking spaces after demo of part of Unit 24 & pool

2-Story attached Bungalow Keys adjacent to Existing Casita

① Site Plan  
1" = 40'-0"



**Sanctuary Interstitial Keys**  
 The Sanctuary Resort on Camelback Mountain

Project Site Plan

Project number	1605
Date	9 January 2017
Scale	1" = 40'-0"

**A3**  
Attachment 1

**WEEKEND**

**APPENDIX D**

**PEAK USE SHARED PARKING CALCULATIONS**

**WEEKEND**

**Ultimate**

**(Spa Expansion with Bungalows)**

Land Use	Sanctuary												SHARED PARKING DEMAND	
	Resort Guest Rooms	Resort Employees	Restaurant	Conference	Spa	Retail	Residential	% OF PEAK	# OF SPC	% OF PEAK	# OF SPC	% OF PEAK		# OF SPC
Gross Size	174±25 Rooms	3,529 SF	6,349 SF	8,400±414 SF	10,247 SF	640 SF	0 Units							
Percent Adjustment	None	None	None	None	None	None	None							
Net Size	174 Rooms	3,529 SF	6,349 SF	8,400 SF	10,247 SF	640 SF	48 Units							
Parking Rate	1.2 /Room	1 /300 SF	1 /50 SF	1 /50 SF	1 /300 SF	1 /300 SF	1.2 /Unit							
Req-d Spaces	210	15	45	152	19	2	0							
Adjustments	None	None	w/ 75% Non guest	w/ 90% Non-guest (ballroom) & 90% Non-guest (Lawn)	w/ 60% Non-guest	w/ 60% Non-guest	None							
Time of Day	% OF PEAK	# OF SPC	% OF PEAK	# OF SPC	% OF PEAK	# OF SPC	% OF PEAK	# OF SPC	% OF PEAK	# OF SPC	% OF PEAK	# OF SPC	% OF PEAK	# OF SPC
6:00 AM	100%	210	20%	9	0%	0	0%	1	0%	0	0%	0	0%	0
7:00 AM	100%	210	20%	9	0%	0	10%	2	3%	1	0%	0	0%	0
8:00 AM	100%	210	20%	9	50%	76	40%	8	10%	1	0%	0	0%	0
9:00 AM	70%	147	20%	9	100%	152	55%	11	30%	1	0%	0	0%	0
10:00 AM	65%	137	20%	9	100%	152	75%	15	45%	1	0%	0	0%	0
11:00 AM	65%	137	30%	14	100%	152	90%	18	70%	2	0%	0	0%	0
12:00 PM	65%	137	30%	14	100%	152	100%	19	85%	2	0%	0	0%	0
1:00 PM	65%	137	45%	21	100%	152	100%	19	95%	2	0%	0	0%	0
2:00 PM	65%	137	45%	21	100%	152	100%	19	100%	2	0%	0	0%	0
3:00 PM	65%	137	45%	21	100%	152	100%	19	100%	2	0%	0	0%	0
4:00 PM	70%	147	45%	21	100%	152	85%	17	90%	2	0%	0	0%	0
5:00 PM	75%	158	60%	27	80%	122	65%	13	75%	2	0%	0	0%	0
6:00 PM	80%	168	90%	41	80%	122	35%	7	65%	2	0%	0	0%	0
7:00 PM	90%	189	95%	43	80%	122	15%	3	10%	1	0%	0	0%	0
8:00 PM	90%	189	100%	45	80%	122	10%	2	10%	1	0%	0	0%	0
9:00 PM	90%	189	70%	11	80%	122	5%	1	10%	1	0%	0	0%	0
10:00 PM	90%	189	60%	9	80%	122	0%	0	0%	0	0%	0	0%	0
11:00 PM	100%	210	20%	9	80%	122	0%	0	0%	0	0%	0	0%	0
MIDNIGHT	100%	210	0%	0	80%	122	0%	0	0%	0	0%	0	0%	0
Number of Parking Spaces With Shared Parking for Sanctuary													371	
Number of Non-Shared Parking Required by City Code for Sanctuary													443	

Project #: 15-1114-008

**TMC SUMMARY OF Scottsdale Rd. & McDonald Dr.**

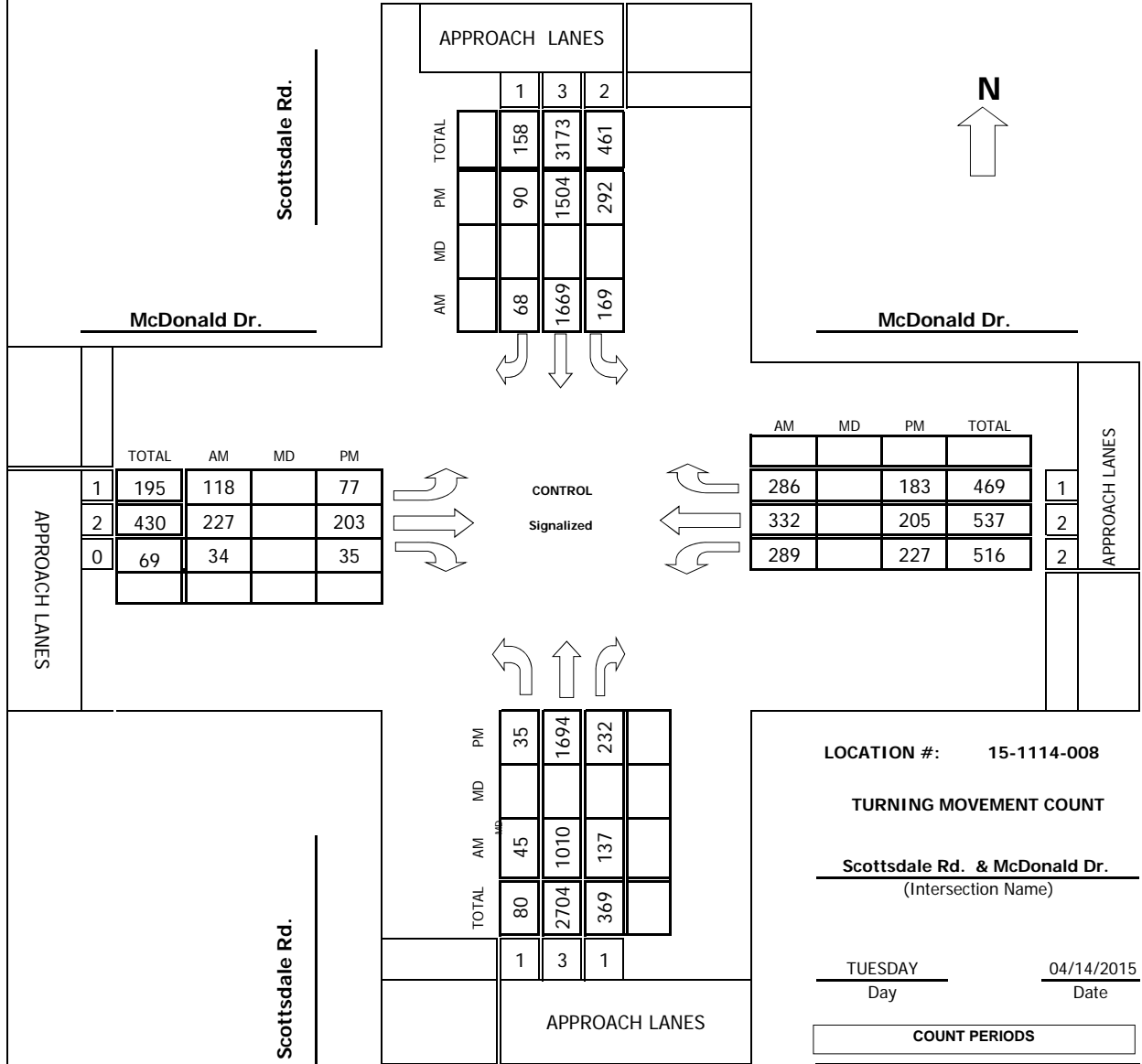

	TOTAL	AM	MD	PM
1	195	118		77
2	430	227		203
0	69	34		35

	AM	MD	PM	TOTAL
1	286		183	469
2	332		205	537
2	289		227	516

	TOTAL	AM	MD	PM
1	80	45		35
3	2704	1010		1694
1	369	137		232

LOCATION #: 15-1114-008

**TURNING MOVEMENT COUNT**

**Scottsdale Rd. & McDonald Dr.**  
 (Intersection Name)

TUESDAY                      04/14/2015  
 Day                                      Date

COUNT PERIODS	
AM	700AM - 900AM
NOON	-
PM	400PM - 600PM

AM PEAK HOUR                      745 AM

NOON PEAK HOUR                      \_\_\_\_\_

PM PEAK HOUR                      445 PM



Project #: 15-1114-004

**TMC SUMMARY OF Mockingbird Ln. & McDonald Dr.**

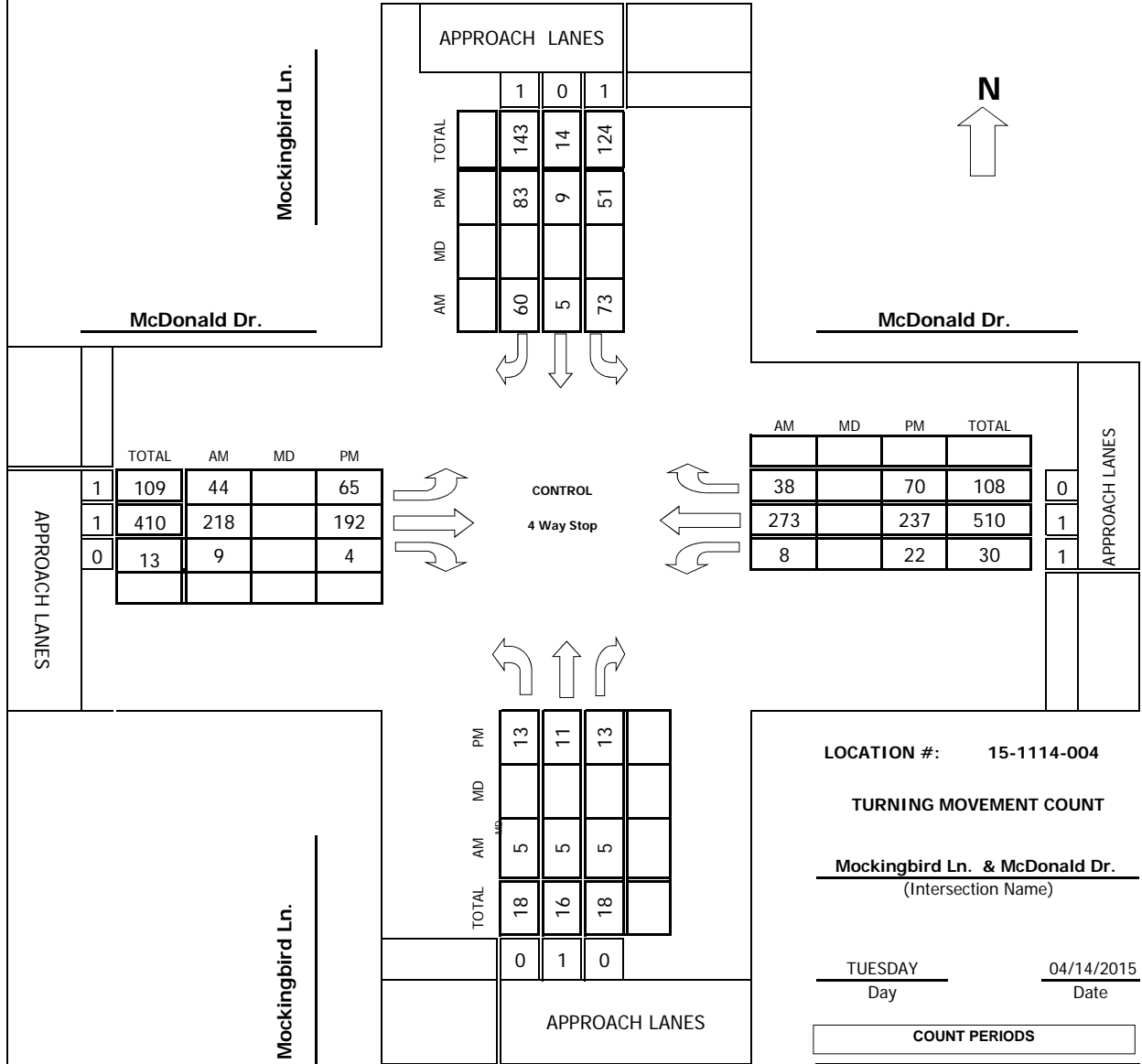

LOCATION #: 15-1114-004

**TURNING MOVEMENT COUNT**

**Mockingbird Ln. & McDonald Dr.**  
(Intersection Name)

TUESDAY                      04/14/2015  
Day                                      Date

COUNT PERIODS		
AM	700AM	- 900AM
NOON	-	-
PM	400PM	- 600PM

AM PEAK HOUR                      800 AM

NOON PEAK HOUR                      \_\_\_\_\_

PM PEAK HOUR                      500 PM



Intersection TMC: 1400028  
Count Date: 01/28/2014

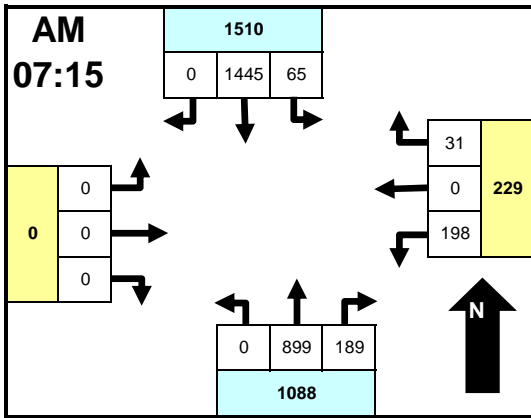

Time	From North TATUM BLVD				From East MCDONALD RD				From South TATUM BLVD				From West NONE				INTSEC TOTAL	
	LT	Thru	RT	Ped	LT	Thru	RT	Ped	LT	Thru	RT	Ped	LT	Thru	RT	Ped		
7:00	12	219	0	0	23	0	10	0	0	139	22	0	0	0	0	0	0	425
7:15	16	375	0	0	50	0	4	0	0	189	41	0	0	0	0	0	0	675
7:30	12	359	0	0	66	0	9	0	0	253	53	0	0	0	0	0	0	752
7:45	13	344	0	0	48	0	9	0	0	242	60	0	0	0	0	0	0	716
8:00	24	367	0	0	34	0	9	0	0	215	35	0	0	0	0	0	0	684
8:15	17	324	0	0	38	0	9	0	0	193	36	0	0	0	0	0	0	617
8:30	23	313	0	0	36	0	13	0	0	193	32	0	0	0	0	0	0	610
8:45	22	218	0	0	34	0	8	0	0	210	33	0	0	0	0	0	0	525
<b>Total</b>	<b>139</b>	<b>2519</b>	<b>0</b>	<b>0</b>	<b>329</b>	<b>0</b>	<b>71</b>	<b>0</b>	<b>0</b>	<b>1634</b>	<b>312</b>	<b>0</b>	<b>0</b>	<b>0</b>	<b>0</b>	<b>0</b>	<b>0</b>	<b>5004</b>
<b>Peak</b>	<b>65</b>	<b>1445</b>	<b>0</b>	<b>0</b>	<b>198</b>	<b>0</b>	<b>31</b>	<b>0</b>	<b>0</b>	<b>899</b>	<b>189</b>	<b>0</b>	<b>0</b>	<b>0</b>	<b>0</b>	<b>0</b>	<b>0</b>	<b>2827</b>

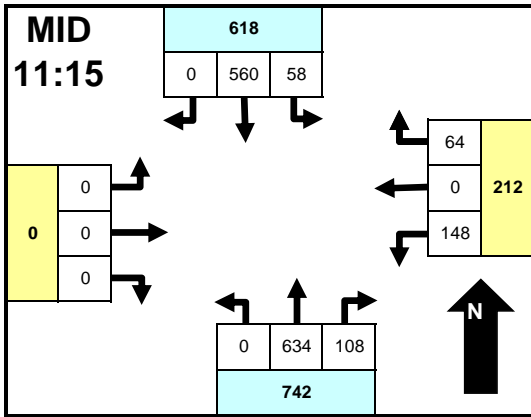

Time	From North TATUM BLVD				From East MCDONALD RD				From South TATUM BLVD				From West NONE				INTSEC TOTAL	
	LT	Thru	RT	Ped	LT	Thru	RT	Ped	LT	Thru	RT	Ped	LT	Thru	RT	Ped		
11:00	19	135	0	0	32	0	16	0	0	134	39	0	0	0	0	0	0	375
11:15	14	146	0	0	39	0	17	0	0	142	29	0	0	0	0	0	0	387
11:30	11	145	0	0	41	0	13	0	0	169	21	0	0	0	0	0	0	400
11:45	18	135	0	0	29	0	12	0	0	168	28	0	0	0	0	0	0	390
12:00	15	134	0	0	39	0	22	0	0	155	30	0	0	0	0	0	0	395
12:15	11	172	0	0	18	0	5	0	0	133	18	0	0	0	0	0	0	357
12:30	15	134	0	0	24	0	23	0	0	151	28	0	0	0	0	0	0	375
12:45	13	158	0	0	33	0	22	0	0	166	42	0	0	0	0	0	0	434
<b>Total</b>	<b>116</b>	<b>1159</b>	<b>0</b>	<b>0</b>	<b>255</b>	<b>0</b>	<b>130</b>	<b>0</b>	<b>0</b>	<b>1218</b>	<b>235</b>	<b>0</b>	<b>0</b>	<b>0</b>	<b>0</b>	<b>0</b>	<b>0</b>	<b>3113</b>
<b>Peak</b>	<b>58</b>	<b>560</b>	<b>0</b>	<b>0</b>	<b>148</b>	<b>0</b>	<b>64</b>	<b>0</b>	<b>0</b>	<b>634</b>	<b>108</b>	<b>0</b>	<b>0</b>	<b>0</b>	<b>0</b>	<b>0</b>	<b>0</b>	<b>1572</b>

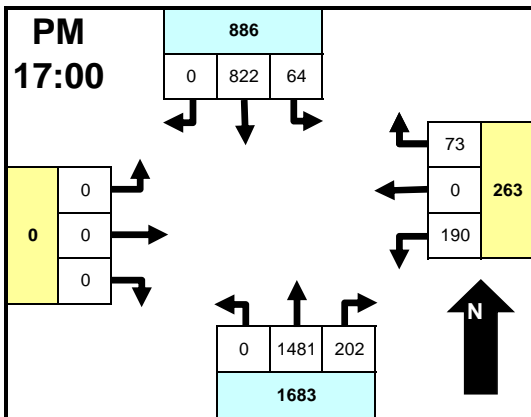

Time	From North TATUM BLVD				From East MCDONALD RD				From South TATUM BLVD				From West NONE				INTSEC TOTAL	
	LT	Thru	RT	Ped	LT	Thru	RT	Ped	LT	Thru	RT	Ped	LT	Thru	RT	Ped		
16:00	15	177	0	0	47	0	19	0	0	251	39	0	0	0	0	0	0	548
16:15	16	158	0	0	40	0	28	0	0	304	47	0	0	0	0	0	0	593
16:30	8	232	0	0	42	0	26	0	0	305	42	0	0	0	0	0	0	655
16:45	20	183	0	0	49	0	16	0	0	309	43	0	0	0	0	0	0	620
17:00	19	209	0	0	53	0	18	0	0	377	60	0	0	0	0	0	0	736
17:15	10	220	0	0	29	0	8	0	0	379	48	0	0	0	0	0	0	694
17:30	15	202	0	0	65	0	24	0	0	363	49	0	0	0	0	0	0	718
17:45	20	191	0	0	43	0	23	0	0	362	45	0	0	0	0	0	0	684
<b>Total</b>	<b>123</b>	<b>1572</b>	<b>0</b>	<b>0</b>	<b>368</b>	<b>0</b>	<b>162</b>	<b>0</b>	<b>0</b>	<b>2650</b>	<b>373</b>	<b>0</b>	<b>0</b>	<b>0</b>	<b>0</b>	<b>0</b>	<b>0</b>	<b>5248</b>
<b>Peak</b>	<b>64</b>	<b>822</b>	<b>0</b>	<b>0</b>	<b>190</b>	<b>0</b>	<b>73</b>	<b>0</b>	<b>0</b>	<b>1481</b>	<b>202</b>	<b>0</b>	<b>0</b>	<b>0</b>	<b>0</b>	<b>0</b>	<b>0</b>	<b>2832</b>

**Intersection Statistics**

Per	Peak Hour	Pk Hr Vol	Peak Intvl	Pk Intv Vol
AM	7:15 AM	2827	7:30 AM	752
MID	11:15 AM	1572	12:45 PM	434
PM	5:00 PM	2832	5:00 PM	736

**Approach Statistics**

Per	Peak Hour	Pk Hr Vol	Peak Hour	Pk Hr Vol	Peak Hour	Pk Hr Vol	Peak Hour	Pk Hr Vol
AM	7:15 AM	1510	7:15 AM	229	7:15 AM	1088		
MID	12:00 PM	652	11:15 AM	212	11:15 AM	742		
PM	4:30 PM	901	4:15 PM	272	5:00 PM	1683		

**Comments**

**Approach & Departure Volumes (No Peds)**

Per	Approach	Depart	Approach	Depart	Approach	Depart	Approach	Depart
AM	2658	1705	400	451	1946	2848	0	0
MID	1275	1348	385	351	1453	1414	0	0
PM	1695	2812	530	496	3023	1940	0	0

**TWSC AM**  
**3: Superstition Lane/Nauni Valley Drive & McDonald Drive**

**TWSC PM**  
**3: Superstition Lane/Nauni Valley Drive & McDonald Drive**

Intersection														
Int Delay, s/vch														
1.8														
Movement	EBL	EBT	EBR	WBL	WBT	WBR	NBL	NBT	NBR	SBL	SBT	SBR	SBR	
Lane Configurations														
Traffic Vol, veh/h	1	261	90	111	269	1	9	0	10	3	0	3		
Future Vol, veh/h	1	261	90	111	269	1	9	0	10	3	0	3		
Conflicting Peds, #/hr	0	0	0	0	0	0	0	0	0	0	0	0		
Sign Control	Free	Free	Free	Free	Free	Free	Free	Free	Free	Free	Free	Free	Free	
RT Channelized	-	-	None	-	-	None	-	-	None	-	-	None	-	
Storage Length	575	-	-	575	-	-	-	-	-	-	-	-	-	
Veh in Median Storage, #	-	0	-	-	0	-	-	0	-	-	-	-	-	
Grade, %	-	0	-	-	0	-	-	0	-	-	-	-	-	
Peak Hour Factor	92	92	92	92	92	92	92	92	92	92	92	92	92	
Heavy Vehicles, %	2	2	2	2	2	2	2	2	2	2	2	2	2	
Mgmt Flow	1	284	98	121	292	1	10	0	11	3	0	3		
Major/Minor	Major1	Major2						Minor1	Minor2					
Conflicting Flow All	293	0	0	382	0	0	871	870	333	874	918	293		
Stage 1	-	-	-	-	-	-	335	335	-	534	534	-		
Stage 2	-	-	-	-	-	-	536	535	-	340	384	-		
Critical Hdwy	4.12	-	-	4.12	-	-	7.12	6.52	6.22	7.12	6.52	6.22		
Critical Hdwy Stg 1	-	-	-	-	-	-	6.12	5.52	-	6.12	5.52	-		
Critical Hdwy Stg 2	-	-	-	-	-	-	6.12	5.52	-	6.12	5.52	-		
Follow-up Hdwy	2.218	-	-	2.218	-	-	3.518	4.018	3.318	3.518	4.018	3.318		
Pot Cap-1 Maneuver	1269	-	-	1176	-	-	271	290	709	270	272	746		
Stage 1	-	-	-	-	-	-	679	643	-	530	524	-		
Stage 2	-	-	-	-	-	-	529	524	-	675	611	-		
Platoon blocked, %	-	-	-	-	-	-	-	-	-	-	-	-		
Mov Cap-1 Maneuver	1269	-	-	1176	-	-	248	260	709	245	244	746		
Mov Cap-2 Maneuver	-	-	-	-	-	-	248	260	-	245	244	-		
Stage 1	-	-	-	-	-	-	678	642	-	530	470	-		
Stage 2	-	-	-	-	-	-	472	470	-	664	611	-		
Approach	EB	WB						NB	SB					
HCM Control Delay, s	0	2.5						15.1	14.9					
HCM LOS								C	B					
Minor Lane/Major Mvmt	NBLn1	EBL	EBT	EBR	WBL	WBT	WBR	SBLn1	SBL	SBLn1	SBL	SBLn1	SBL	
Capacity (veh/h)	377	1269	-	-	1176	-	-	369	-	-	-	369	-	
HCM Lane V/C Ratio	0.055	0.001	-	-	0.103	-	-	0.018	-	-	-	0.018	-	
HCM Control Delay (s)	15.1	7.8	-	-	8.4	-	-	14.9	-	-	-	14.9	-	
HCM Lane LOS	C	A	-	-	A	-	-	B	-	-	-	B	-	
HCM 95th %ile Q(veh)	0.2	0	-	-	0.3	-	-	0.1	-	-	-	0.1	-	

Intersection														
Int Delay, s/vch														
4.4														
Movement	EBL	EBT	EBR	WBL	WBT	WBR	NBL	NBT	NBR	SBL	SBT	SBR	SBR	
Lane Configurations														
Traffic Vol, veh/h	3	253	13	18	317	3	88	0	106	1	0	1		
Future Vol, veh/h	3	253	13	18	317	3	88	0	106	1	0	1		
Conflicting Peds, #/hr	0	0	0	0	0	0	0	0	0	0	0	0		
Sign Control	Free	Free	Free	Free	Free	Free	Free	Free	Free	Free	Free	Free	Free	
RT Channelized	-	-	None	-	-	None	-	-	None	-	-	None	-	
Storage Length	575	-	-	575	-	-	-	-	-	-	-	-	-	
Veh in Median Storage, #	-	0	-	-	0	-	-	0	-	-	-	-	-	
Grade, %	-	0	-	-	0	-	-	0	-	-	-	-	-	
Peak Hour Factor	92	92	92	92	92	92	92	92	92	92	92	92	92	
Heavy Vehicles, %	2	2	2	2	2	2	2	2	2	2	2	2	2	
Mgmt Flow	3	275	14	20	345	3	96	0	115	1	0	1		
Major/Minor	Major1	Major2						Minor1	Minor2					
Conflicting Flow All	348	0	0	289	0	0	675	676	282	731	681	346		
Stage 1	-	-	-	-	-	-	289	289	-	385	385	-		
Stage 2	-	-	-	-	-	-	386	387	-	346	296	-		
Critical Hdwy	4.12	-	-	4.12	-	-	7.12	6.52	6.22	7.12	6.52	6.22		
Critical Hdwy Stg 1	-	-	-	-	-	-	6.12	5.52	-	6.12	5.52	-		
Critical Hdwy Stg 2	-	-	-	-	-	-	6.12	5.52	-	6.12	5.52	-		
Follow-up Hdwy	2.218	-	-	2.218	-	-	3.518	4.018	3.318	3.518	4.018	3.318		
Pot Cap-1 Maneuver	1211	-	-	1273	-	-	368	375	757	337	373	697		
Stage 1	-	-	-	-	-	-	719	673	-	638	611	-		
Stage 2	-	-	-	-	-	-	637	610	-	670	668	-		
Platoon blocked, %	-	-	-	-	-	-	-	-	-	-	-	-		
Mov Cap-1 Maneuver	1211	-	-	1273	-	-	362	368	757	282	366	697		
Mov Cap-2 Maneuver	-	-	-	-	-	-	362	368	-	282	366	-		
Stage 1	-	-	-	-	-	-	717	671	-	636	601	-		
Stage 2	-	-	-	-	-	-	626	600	-	567	666	-		
Approach	EB	WB						NB	SB					
HCM Control Delay, s	0.1	0.4						17.1	14					
HCM LOS								C	B					
Minor Lane/Major Mvmt	NBLn1	EBL	EBT	EBR	WBL	WBT	WBR	SBLn1	SBL	SBLn1	SBL	SBLn1	SBL	
Capacity (veh/h)	506	1211	-	-	1273	-	-	402	-	-	-	402	-	
HCM Lane V/C Ratio	0.417	0.003	-	-	0.015	-	-	0.005	-	-	-	0.005	-	
HCM Control Delay (s)	17.1	8	-	-	7.9	-	-	14	-	-	-	14	-	
HCM Lane LOS	C	A	-	-	A	-	-	B	-	-	-	B	-	
HCM 95th %ile Q(veh)	2	0	-	-	0	-	-	0	-	-	-	0	-	

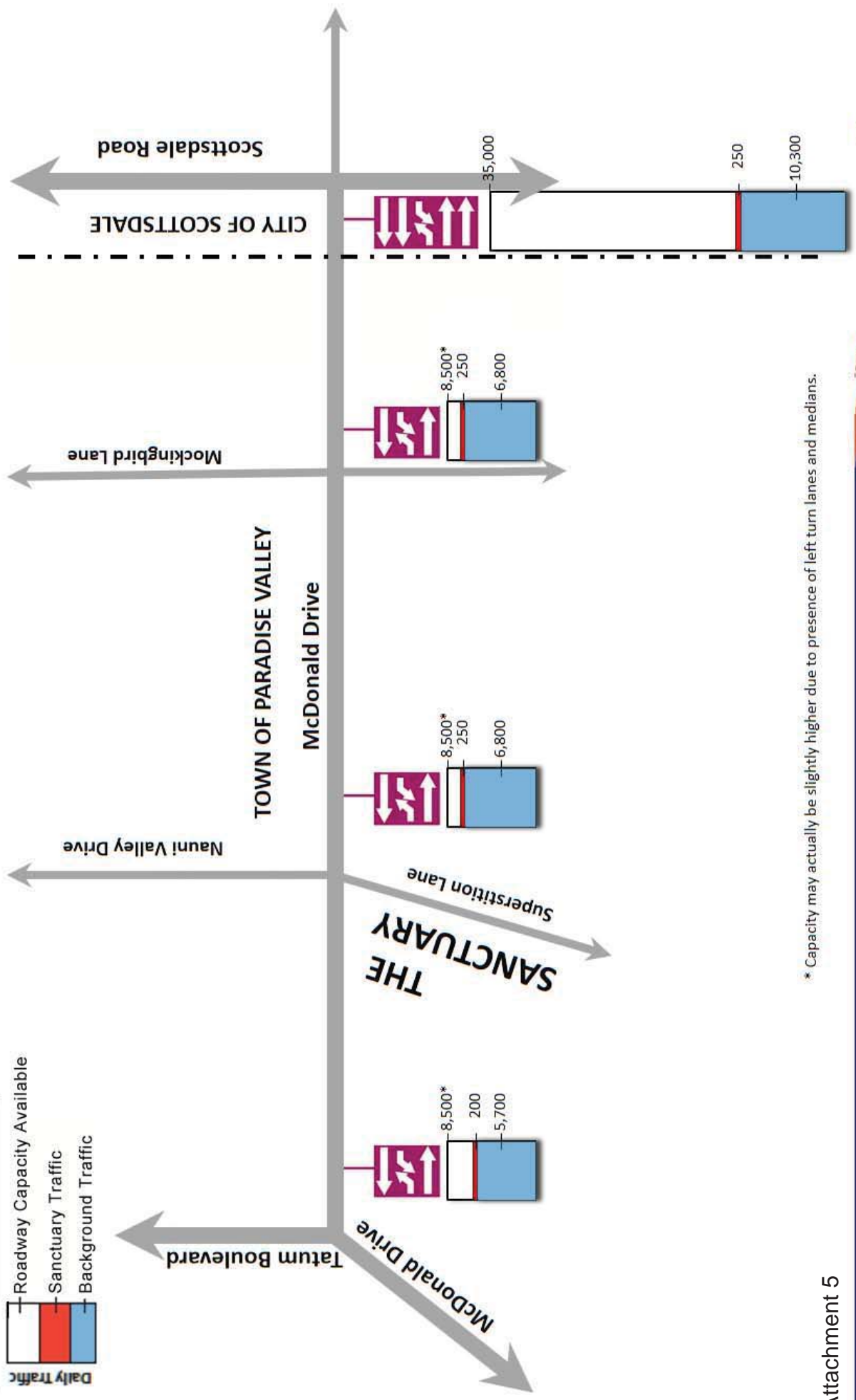
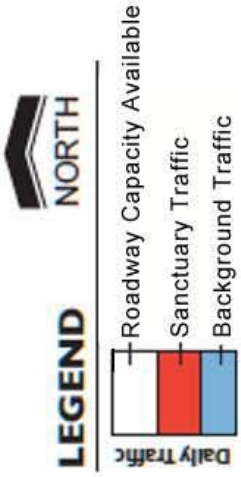

\* Capacity may actually be slightly higher due to presence of left turn lanes and medians.