

FINAL PLAT FOR  
**THE VILLAS AT MOUNTAIN SHADOWS II**  
 A RE-SUBDIVISION OF LOTS 133 AND 134 OF "MOUNTAIN SHADOW RESORT  
 UNIT 2 - AMENDED VII" AS RECORDED IN BOOK 1232 OF MAPS, PAGE 27 IN THE  
 OFFICE OF THE MARICOPA COUNTY RECORDER AND SITUATED IN THE  
 SOUTHEAST QUARTER OF SECTION 8, TOWNSHIP 2 NORTH, RANGE 4 EAST,  
 OF THE GILA AND SALT RIVER BASE AND MERIDIAN, MARICOPA COUNTY, ARIZONA

**COUNTY RECORDER**

OFFICIAL RECORDS OF  
 MARICOPA COUNTY RECORDER  
 HELEN PURCELL  
 20150842150, 11/25/2015 10:45  
 BOOK 1251 PAGE 16  
 ELECTRONIC RECORDING  
 PLAT1513-2-1-1-M-

**CVL CONSULTANTS**  
 4550 North 12th Street  
 Phoenix, Arizona 85014  
 602-264-6831  
 www.cvlci.com

**DEDICATION**

STATE OF ARIZONA )  
 ) SS  
 COUNTY OF MARICOPA )

KNOW ALL MEN BY THESE PRESENTS:

THAT MTS LAND, LLC, A DELAWARE LIMITED LIABILITY COMPANY, AS OWNER, HAS SUBDIVIDED UNDER THE NAME OF "THE VILLAS AT MOUNTAIN SHADOWS II" A RE-SUBDIVISION OF LOTS 133 AND 134 OF "MOUNTAIN SHADOW RESORT UNIT 2 - AMENDED VII" AS RECORDED IN BOOK 1232 OF MAPS, PAGE 27 IN THE OFFICE OF THE MARICOPA COUNTY RECORDER AND IS SITUATED IN THE SOUTHEAST QUARTER OF SECTION 8, TOWNSHIP 2 NORTH, RANGE 4 EAST, OF THE GILA AND SALT RIVER BASE AND MERIDIAN, MARICOPA COUNTY, ARIZONA, AS SHOWN PLATTED HEREON AND HEREBY PUBLISHES THIS PLAT AND DECLARES THAT THIS PLAT SETS FORTH THE LOCATION AND GIVES THE DIMENSIONS OF THE LOTS AND TRACTS CONSTITUTING SAME AND THAT EACH LOT AND TRACT SHALL BE KNOWN BY THE NUMBER OR LETTER GIVEN EACH RESPECTIVELY ON SAID PLAT.

MTS LAND, LLC, A DELAWARE LIMITED LIABILITY COMPANY, AS OWNER, HEREBY DEDICATES TO THE WATER, SEWER, NATURAL GAS, ELECTRIC, TELEPHONE, AND CABLE TELEVISION UTILITY PROVIDERS AND RESERVES FOR THE "VILLAS AT MOUNTAIN SHADOWS" HOMEOWNERS ASSOCIATION OR ANY SUBASSOCIATION DESIGNATED BY SUCH ASSOCIATION (COLLECTIVELY, THE "ASSOCIATION") AN UNDERGROUND PUBLIC UTILITY EASEMENT UNDER AND ACROSS TRACT B, TRACT C, TRACT D, AND THOSE AREAS SHOWN ON THIS PLAT AS EASEMENTS DEDICATED HEREON FOR THE INSTALLATION, MAINTENANCE, REPAIR, AND REMOVAL OF UNDERGROUND PUBLIC AND PRIVATE WATER LINES, PRIVATE SEWER LINES, NATURAL GAS, ELECTRIC, TELEPHONE, AND CABLE TELEVISION UTILITIES STRICTLY AS NECESSARY TO PROVIDE SUCH UTILITY SERVICES AND SOLELY FOR THE PURPOSE OF PROVIDING SUCH UTILITY SERVICES TO OR FROM LOTS 128, 128-A, 129, 131, 132, 133, 134, 135, AND TRACT "A" OF AMENDED VII. THIS UNDERGROUND EASEMENT ALSO INCLUDES AN EASEMENT FOR ANY ABOVE GROUND FACILITIES REQUIRED BY UTILITY PROVIDERS IN CONNECTION WITH THE UTILITIES. MAINTENANCE OF THE AREAS SUBJECT TO UTILITY EASEMENTS SHALL BE THE RESPONSIBILITY OF THE LOT OWNER, TRACT OWNER, OR ASSOCIATION, AS DETERMINED BY THE ASSOCIATION.

TRACT B IS DEDICATED AS A PRIVATE DRIVE.

AN EASEMENT FOR DRAINAGE IS HEREBY DEDICATED OVER AND ACROSS TRACT B AND TRACT C TO THE TOWN OF PARADISE VALLEY AND TO THE ASSOCIATION, WHICH ASSOCIATION ALSO BENEFITS.

AN EASEMENT FOR REFUSE COLLECTION AND EMERGENCY AND SIMILAR SERVICE TYPE VEHICLE ACCESS IS HEREBY DEDICATED OVER AND ACROSS TRACT B TO THE TOWN OF PARADISE VALLEY AND OTHER EMERGENCY SERVICE PROVIDERS AND REFUSE COLLECTION PROVIDERS AND TO THE ASSOCIATION, WHICH ASSOCIATION ALSO BENEFITS.

TRACT C AND TRACT D ARE HEREBY DEDICATED FOR THE ADDITIONAL PURPOSES SHOWN IN THE TRACT TABLE.

TRACT B AND TRACT C ARE NOT DEDICATED FOR THE USE OF THE GENERAL PUBLIC. TRACT B, TRACT C, AND TRACT D SHALL BE OWNED AND MAINTAINED BY THE ASSOCIATION.

IN WITNESS WHEREOF:

MTS LAND LLC, A DELAWARE LIMITED LIABILITY COMPANY, AS OWNER OF THE LAND DESCRIBED HEREIN, HAS CAUSED ITS NAME TO BE AFFIXED AND THE SAME TO BE ATTESTED BY THE SIGNATURE OF THE UNDERSIGNED DULY AUTHORIZED OFFICER.

MTS LAND LLC, A DELAWARE LIMITED LIABILITY COMPANY

BY: Robert A. Flaxman DATE: 11/10/15  
 ITS: AUTHORIZED SIGNATORY

**CERTIFICATION**

I, LARRY E. SULLIVAN, HEREBY CERTIFY THAT I AM A REGISTERED LAND SURVEYOR IN THE STATE OF ARIZONA, THAT THIS MAP, CONSISTING OF TWO (2) SHEETS, CORRECTLY REPRESENTS A BOUNDARY SURVEY MADE UNDER MY SUPERVISION DURING THE MONTH OF JUNE, 2015, THAT THE SURVEY IS TRUE AND COMPLETE AS SHOWN, THAT ALL MONUMENTS SHOWN ACTUALLY EXIST OR WILL BE SET AS SHOWN, THAT THEIR POSITIONS ARE CORRECTLY SHOWN AND THAT SAID MONUMENTS ARE SUFFICIENT TO ENABLE THE SURVEY TO BE RETRACED.

BY: Larry E. Sullivan  
 LARRY E. SULLIVAN  
 REGISTRATION NUMBER 22782  
 4550 N. 12TH STREET  
 PHOENIX, ARIZONA 85014  
 (602)-264-6831  
 CVL.SURVEY@CVL.CI.COM

**NOTES**

- ALL ELECTRIC, NATURAL GAS, TELEPHONE AND CABLE TV SERVICE LINES WILL BE INSTALLED UNDERGROUND EXCEPT AS REQUIRED BY THE UTILITY PROVIDERS.
- CONSTRUCTION WITHIN UTILITY EASEMENTS, EXCEPT BY PUBLIC AGENCIES AND UTILITY COMPANIES SHALL BE LIMITED TO WOOD AND WIRE OR REMOVABLE SECTION TYPE FENCING AND MUST BE IN CONFORMANCE WITH APPLICABLE DEED RESTRICTIONS, TOWN CODES, AND MAG SPECS AND STANDARD DETAILS.
- THE ELEVATION OF ANY PAD FOR A BUILDING OR STRUCTURE WITHIN THE BASE FLOOD LIMITS OF AN AREA OF SPECIAL HAZARD MUST BE IN ACCORDANCE WITH ARTICLE 5-11 OF THE TOWN OF PARADISE VALLEY TOWN CODE, FLOODPLAIN ADMINISTRATION.
- TRACT B IS A PRIVATE DRIVE. TRACTS B, C AND D CONTAIN EASEMENTS FOR PRIVATE SEWER LINES, PUBLIC & PRIVATE WATER LINES, NATURAL GAS, ELECTRIC, TELEPHONE, CABLE TELEVISION, DRAINAGE, REFUSE COLLECTION, AND EMERGENCY AND SIMILAR SERVICE TYPE VEHICLES.
- THE DEVELOPMENT OF THE LOTS IN "THE VILLAS AT MOUNTAIN SHADOWS II" IS PURSUANT TO THE DEVELOPMENT AGREEMENT AND SPECIAL USE PERMIT FOR MOUNTAIN SHADOWS AS RECORDED IN DOCUMENT NO. 2013-0359723 M.C.R. AND DOCUMENT NO. 2013-0358792 M.C.R. RESPECTIVELY.
- BUILDING HEIGHTS ARE PURSUANT TO THE SPECIAL USE PERMIT (SUP) FOR MOUNTAIN SHADOWS.
- CC&R'S FOR THIS DEVELOPMENT ARE AS PER THE MOUNTAIN SHADOWS AMENDED AND RE-STATEMENT DECLARATION OF COVENANTS, RESTRICTIONS AND EASEMENTS AS RECORDED IN DOCUMENT NO. 2015-0109812 M.C.R., AND AMENDED IN DOCUMENT NO. 2015-0426439 M.C.R. AND THE MOUNTAIN SHADOWS WEST DECLARATION OF COVENANTS, CONDITIONS, RESTRICTIONS AND EASEMENTS AS RECORDED IN DOCUMENT NO. 2015-0109960 M.C.R. AS AMENDED IN DOCUMENT NO. 2015-0426438 M.C.R.
- INDIVIDUAL TRACTS OR LOTS CAN INCLUDE POOLS OR OTHER AMENITIES IN CONFORMANCE WITH APPROVED SPECIAL USE PERMIT (SUP).
- THOSE PORTIONS OF TRACT B AND TRACT D WHICH WILL BE DRIVABLE SURFACES TO BE UTILIZED ONLY BY EMERGENCY VEHICLES SHALL BE CONSTRUCTED WITH MATERIALS TO BE APPROVED BY THE FIRE MARSHAL.

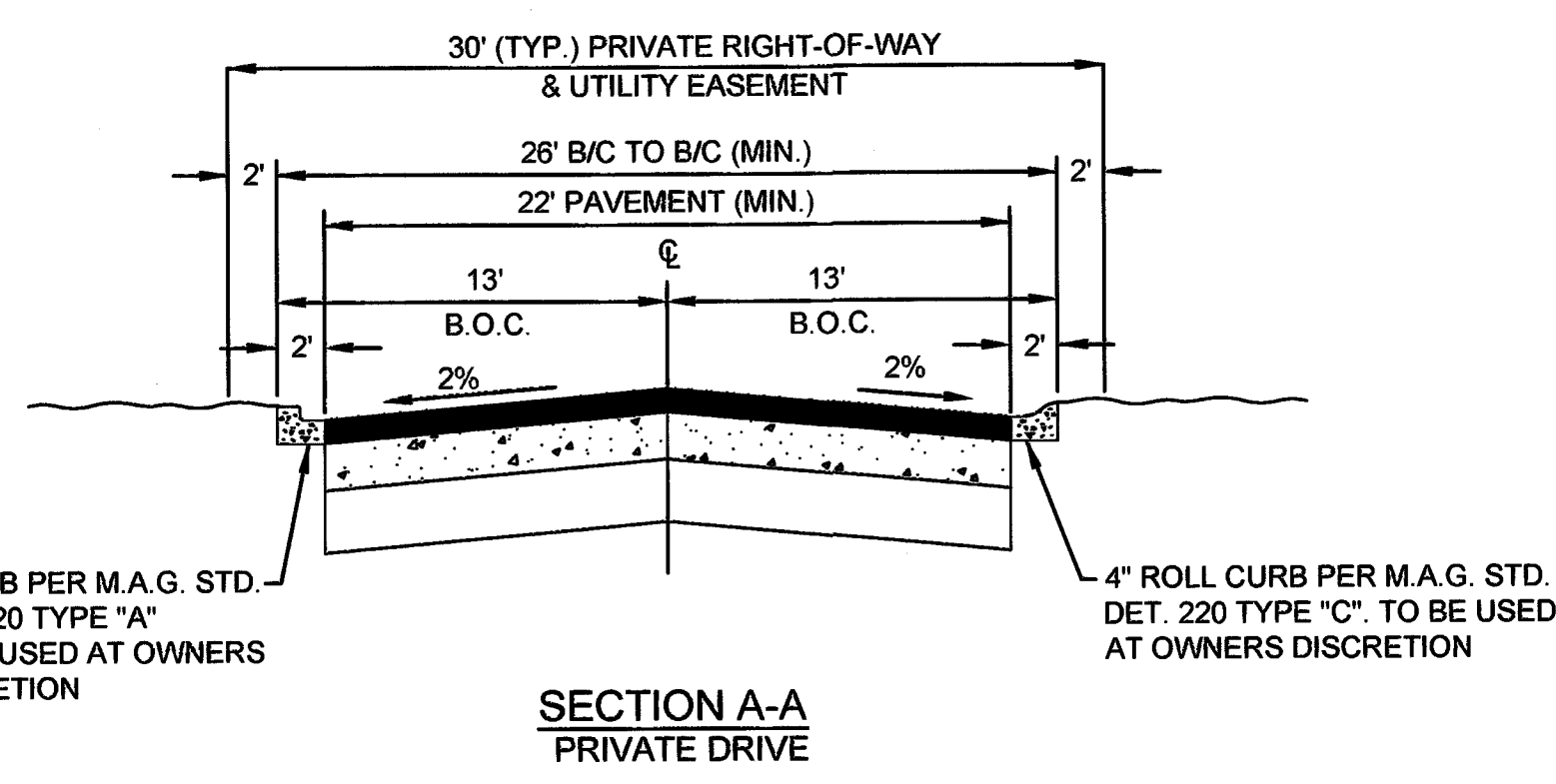
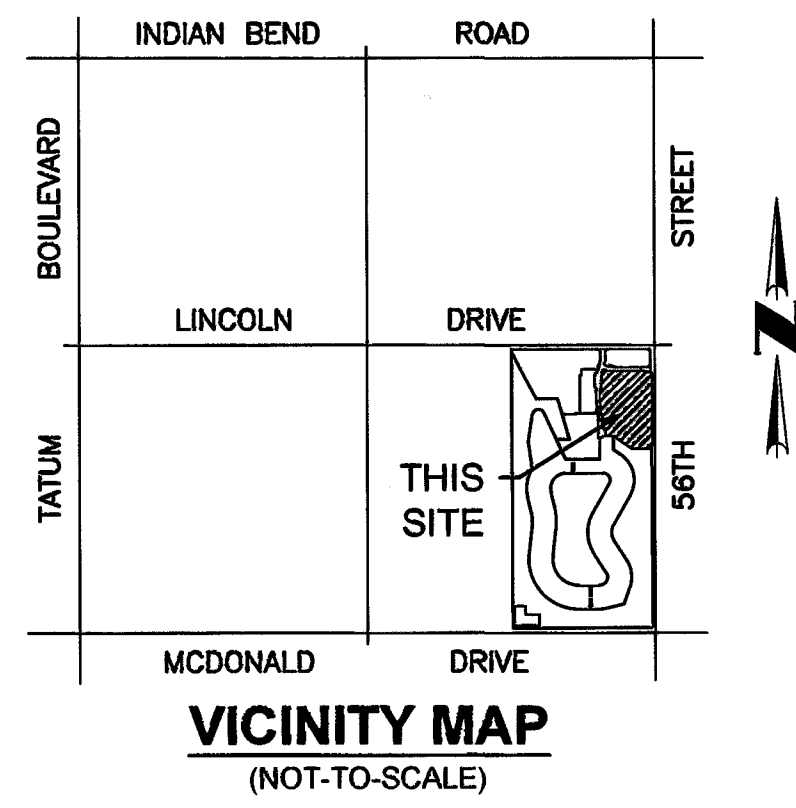

**OWNER**

MTS LAND LLC, A DELAWARE LIMITED LIABILITY COMPANY  
 18201 VON KARMAN AVENUE, SUITE 950  
 IRVINE, CALIFORNIA 92612  
 PHONE: (949) 476-2200  
 CONTACT: ROBERT A. FLAXMAN, CEO

**ENGINEER**

COE & VAN LOO II, INC.  
 4550 NORTH 12TH STREET  
 PHOENIX, ARIZONA 85014  
 PHONE: (602) 264-6831  
 FAX: (602) 264-0928  
 CONTACT: JOSEF PAPPAS, P.E.

**LAND USE TABLE**

PARCEL	AREA
EXISTING ZONING	SUP-RESORT
YIELD	8 LOTS
	4 TRACTS
GROSS / NET AREA	7,138 AC.

**TRACT TABLE**

TRACT	AREA (ACRES)	DESCRIPTION
TRACT 'B'	0.335	PRIVATE DRIVE, DRAINAGE EASEMENT, UTILITY EASEMENTS, OPEN SPACE, LANDSCAPE
TRACT 'C'	0.050	UTILITY EASEMENTS, OPEN SPACE, LANDSCAPE, DRAINAGE EASEMENT, GOLF CART PATH
TRACT 'D'	0.073	UTILITY EASEMENTS, OPEN SPACE, LANDSCAPE & EMERGENCY ACCESS
TRACT 'E'	5.166	FUTURE DEVELOPMENT
TOTAL	5.624	

**EASEMENT SCHEDULE**

- EASEMENTS SET FORTH IN BOOK 1232 OF MAPS, PAGE 27
- EASEMENT SET FORTH IN DOCKET 4930, PAGE 82

**DRAINAGE EASEMENT RESTRICTIONS**

PURSUANT TO A.R.S. 9-463.01 (C), AND SECTION 6-4 (E)(J), 8-7-1 ET. SEQ. AND 6-3-8 OF THE CODE OF ORDINANCES OF THE TOWN OF PARADISE VALLEY, DRAINAGE EASEMENTS ARE FOR THE PURPOSE OF ALLOWING STORM, FLOOD AND OTHER WATERS TO PASS OVER, UNDER, OR THROUGH THE LAND SET ASIDE FOR SUCH EASEMENTS, AND NOTHING WHICH MAY, TO ANY DEGREE, IMPEDE OR OBSTRUCT THE FLOW OF SUCH WATER, SHALL BE CONSTRUCTED, PLACED, PLANTED OR ALLOWED TO GROW ON OR IN SUCH EASEMENTS. THE MAINTENANCE AND CLEARING OF THESE DRAINAGE EASEMENTS SHALL BE THE SOLE RESPONSIBILITY AND DUTY OF THE OWNER OF THE PROPERTY ON WHICH SAID EASEMENTS ARE PLATTED. HOWEVER, IF THE TOWN DEEMS IT TO BE IN THE BEST INTERESTS OF THE HEALTH, SAFETY, OR WELFARE OF THE TOWN OF PARADISE VALLEY, THE TOWN OF PARADISE VALLEY MAY CONSTRUCT AND/OR MAINTAIN DRAINAGE FACILITIES ON OR UNDER SUCH EASEMENTS. AGENTS AND EMPLOYEES OF THE TOWN OF PARADISE VALLEY SHALL HAVE FREE ACCESS TO AND FROM ALL PORTIONS OF SUCH EASEMENTS AT ALL TIMES.

**100 YEAR ASSURED WATER SUPPLY**

THE AREA PLATTED HEREON LIES WITHIN THE DOMESTIC WATER SERVICE AREA OF EPCOR WATER ARIZONA INC. - PARADISE VALLEY WHICH IS DESIGNATED AS HAVING AN ASSURED WATER SUPPLY PURSUANT TO SECTION 45-576 ARIZONA REVISED STATUTES AS PER ARIZONA DEPARTMENT OF WATER RESOURCES CERTIFICATE NUMBER

21-70839.0000 DATED November 12<sup>th</sup>, 2015.

**BASIS OF BEARING**

THE BASIS OF BEARING FOR THIS SURVEY IS NORTH 00°16'59" WEST ALONG THE WEST LINE OF THE SOUTHWEST QUARTER OF SECTION 9, TOWNSHIP 2 NORTH, RANGE 4 EAST OF THE GILA AND SALT RIVER MERIDIAN, MARICOPA COUNTY, ARIZONA.

**UTILITY PROVIDERS**

SEWER	CITY OF PHOENIX
WATER	EPCOR WATER
TELEPHONE	CENTURYLINK
CABLE	COX COMMUNICATIONS
GAS	SOUTHWEST GAS
ELECTRIC	ARIZONA PUBLIC SERVICE

**ACKNOWLEDGEMENT**

STATE OF CALIFORNIA )  
 ) SS  
 COUNTY OF ORANGE )

ON November 10, 2015 BEFORE ME, ANN M. VERA, A NOTARY PUBLIC,

PERSONALLY APPEARED ROBERT A. FLAXMAN, WHO PROVED TO ME ON THE BASIS OF SATISFACTORY EVIDENCE TO BE THE PERSON WHOSE NAME IS SUBSCRIBED TO THE WITHIN INSTRUMENT AND ACKNOWLEDGED TO ME THAT HE EXECUTED THE SAME IN HIS AUTHORIZED CAPACITY, AND THAT BY HIS SIGNATURE ON THE INSTRUMENT THE PERSON, OR THE ENTITY UPON BEHALF OF WHICH THE PERSON ACTED, EXECUTED THE INSTRUMENT.

I CERTIFY UNDER PENALTY OF PERJURY UNDER THE LAWS OF THE STATE OF CALIFORNIA THAT THE FOREGOING PARAGRAPH IS TRUE AND CORRECT.

WITNESS MY HAND AND OFFICIAL SEAL.

SIGNATURE: Ann M. Vera  
 ANN M. VERA

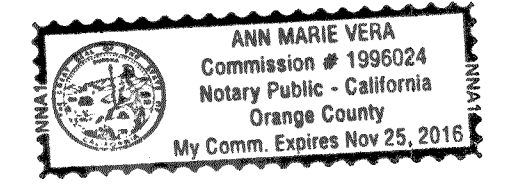

**APPROVAL**

APPROVED BY THE TOWN COUNCIL OF THE TOWN OF PARADISE VALLEY, ARIZONA THIS

19<sup>th</sup> DAY OF NOVEMBER, 2015.

BY: [Signature]  
 MAYOR

ATTEST: [Signature]  
 TOWN CLERK

[Signature]  
 TOWN ENGINEER

[Signature]  
 PLANNING DIRECTOR

GROSS AREA = 7.138 ACRES SEE SHEET 2 FOR CURVE, LINE & LOT AREA TABLES

**FINAL PLAT**

**THE VILLAS AT MOUNTAIN SHADOWS II**  
 PARADISE VALLEY, ARIZONA

**Coe and Van Loo II L.L.C.**

DATE

REVISION

NO.

22782  
 LARRY E. SULLIVAN  
 ARIZONA U.S.A.  
 Expires 6-30-2016

1 SHEET OF 2

CVL Contact: J. PAPPAS  
 CVL Project #: 01-0245801  
 CVL File #:

CURVE TABLE						
NO.	ARC	RADIUS	DELTA	TANGENT	CHORD	CHORD-BEARING
C1	26.11	91.26	016°23'36"	13.15	26.02	N00°57'36"E
C2	45.93	89.42	029°25'52"	23.49	45.43	N20°50'37"W
C3	40.44	70.00	033°06'00"	20.80	39.88	S19°00'33"E
C4	79.40	690.47	006°35'18"	39.74	79.35	N05°45'12"W
C5	74.19	485.00	008°45'52"	37.17	74.12	S04°39'55"E
C6	40.91	100.00	023°26'26"	20.75	40.63	S11°26'14"W
C7	14.97	50.00	017°09'27"	7.54	14.92	N14°34'44"E
C8	18.83	100.00	010°47'15"	9.44	18.80	N00°36'23"E
C9	40.53	24.50	094°47'15"	26.64	36.07	S42°36'23"W
C10	8.41	32.50	014°49'55"	4.23	8.39	N82°35'02"W
C11	8.41	32.50	014°49'55"	4.23	8.39	S82°35'02"E
C12	31.32	20.00	089°43'01"	19.90	28.21	N45°08'29"W
C13	33.55	20.00	096°07'37"	22.26	29.76	S42°07'33"W
C14	10.28	20.00	029°27'28"	5.26	10.17	N75°04'55"W
C15	10.47	20.00	030°00'00"	5.36	10.35	N45°21'11"W
C16	52.30	50.00	059°55'48"	28.83	49.95	S60°19'05"E
C17	20.92	20.00	059°55'48"	11.53	19.98	S60°19'05"E
C18	26.18	50.00	030°00'00"	13.40	25.88	N45°21'11"W
C19	25.71	50.00	029°27'28"	13.14	25.42	N75°04'55"W
C20	28.19	20.00	080°45'48"	17.01	25.92	S49°25'45"E
C21	15.71	10.00	090°00'00"	10.00	14.14	S45°00'00"E
C22	14.07	18.00	044°47'00"	7.42	13.71	N22°23'30"W
C23	42.77	97.42	025°09'04"	21.73	42.42	N22°59'01"W
C24	35.82	62.00	033°06'00"	18.42	35.32	S19°00'33"E
C25	58.27	698.47	004°46'48"	29.15	58.25	N04°50'57"W

LINE TABLE		
NO.	LENGTH	BEARING
L1	17.10	S55°01'49"E
L2	6.00	N00°16'59"W
L3	3.39	S00°00'00"W
L4	7.17	N02°27'33"W
L5	7.00	S89°43'03"W
L6	26.00	N89°43'01"E
L7	26.00	N89°43'01"E

LOT AREA TABLE		
LOT	AREA (SQUARE FEET)	AREA (ACRES)
21	7,691	0.177
22	7,779	0.179
23	8,128	0.187
24	8,471	0.194
25	8,584	0.197
26	7,517	0.173
27	7,452	0.171
28	10,299	0.236
TOTAL	65,921	1.514

**LEGEND**

- ▲--- INDICATES SECTION CORNER - FOUND BRASS CAP (UNLESS OTHERWISE NOTED)
- ⊙--- INDICATES FOUND 1/2" REBAR WITH CAP RLS #22782 (UNLESS OTHERWISE NOTED)
- U.E. INDICATES UTILITY EASEMENT
- L1 INDICATES LINE NUMBER
- C1 INDICATES CURVE NUMBER
- M.C.R. INDICATES MARICOPA COUNTY RECORDER
- APN INDICATES ASSESSOR PARCEL NUMBER
- MAG INDICATES MARICOPA ASSOCIATION OF GOVERNMENTS
- ① INDICATES EASEMENT SCHEDULE NO.

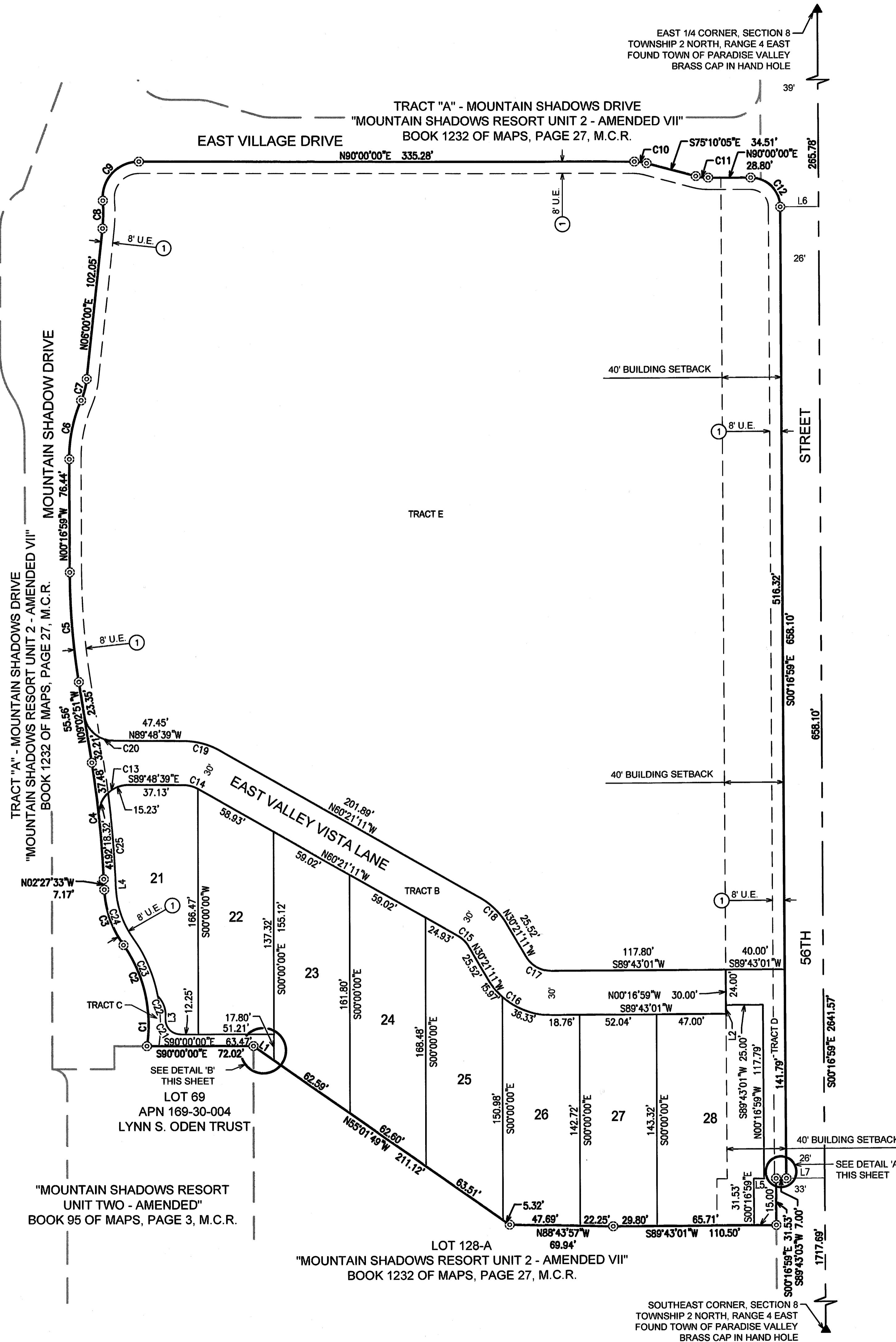

**COUNTY RECORDER**

OFFICIAL RECORDS OF  
 MARICOPA COUNTY RECORDER  
 HELEN PURCELL  
 20150842150, 11/25/2015 10:45  
 BOOK 1251 PAGE 16  
 ELECTRONIC RECORDING  
 PLAT1513-2-1-1-M-

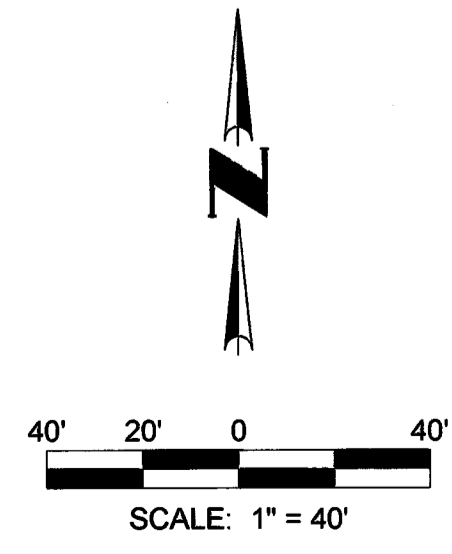
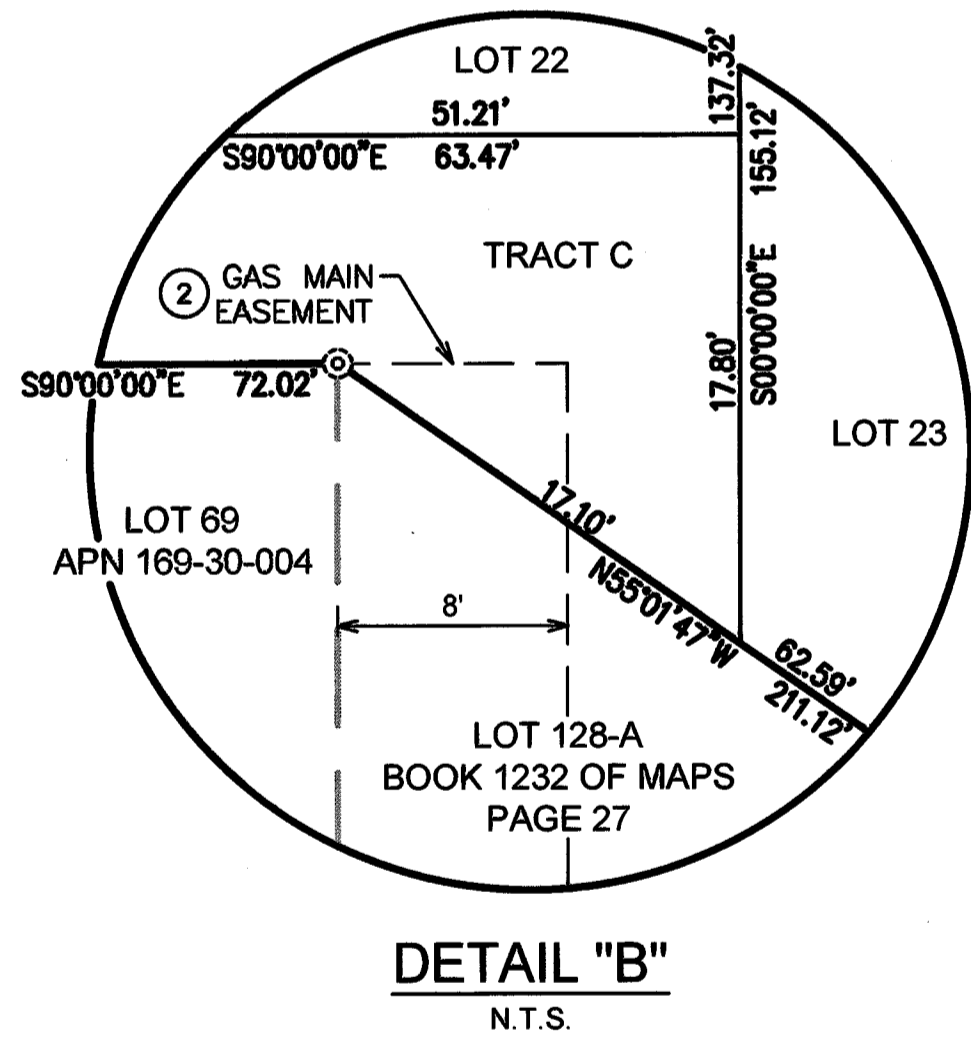
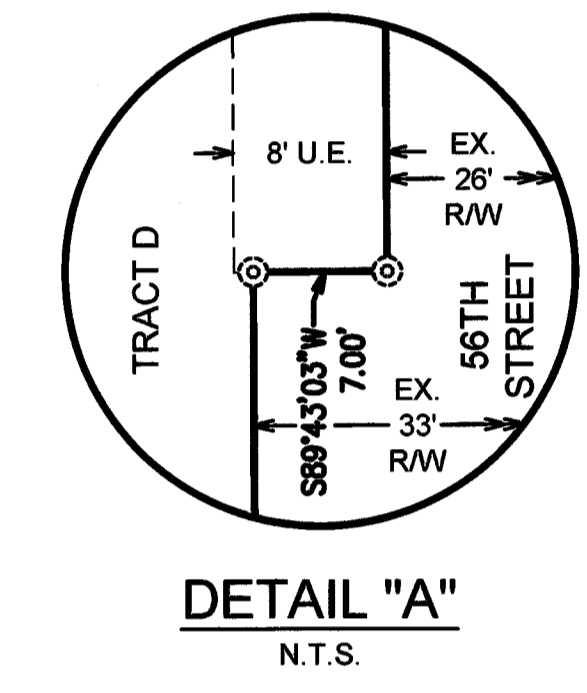

**ICVL CONSULTANTS**  
 4550 North 12th Street  
 Phoenix, Arizona 85014  
 602-264-8831  
 www.cvlci.com

**Coe and Van Loo II L.L.C.**

**FINAL PLAT**

**THE VILLAS AT MOUNTAIN SHADOWS II**  
 PARADISE VALLEY, ARIZONA

22782  
 LARRY E. SULLIVAN  
 COUNTY RECORDER  
 APR 15 2015

2 SHEET OF 2  
 CVL Contact: J. PAPPAS  
 CVL Project #: 01-0245801  
 CVL File #:

# PRELIMINARY MAP "THE VILLAS AT MOUNTAIN SHADOWS CONDOMINIUMS"

## NOTES

- THE BOUNDARIES OF EACH UNIT ARE AS FOLLOWS:  
(A) THE VERTICAL BOUNDARIES ARE THE INTERIOR FINISHED SURFACES OF THE PERIMETER WALLS OF THE UNIT;  
(B) THE LOWER HORIZONTAL BOUNDARY IS THE TOP SURFACE OF THE FLOOR SLAB BENEATH THE UNIT; AND  
(C) THE UPPER AND LOWER HORIZONTAL BOUNDARIES OF EACH UNIT SHALL BE FROM THE UNFINISHED FLOOR OF EACH UNIT TO THE UNFINISHED CEILING OF EACH UNIT.
- THE COMMON ELEMENTS OF THE VILLAS AT MOUNTAIN SHADOWS CONDOMINIUMS, A CONDOMINIUM, WILL CONSIST OF ALL THE PROPERTY WITHIN THE BOUNDARIES OF THE CONDOMINIUM AS SHOWN ON THIS CONDOMINIUM MAP, EXCEPT FOR THE UNITS.
- TIES SHOWN ARE TO OUTSIDE FACE OF BUILDINGS (GROUND LEVEL)
- EASEMENTS FOR THE PRIVATE DRIVES, PUBLIC AND PRIVATE UTILITIES, AND EMERGENCY AND SERVICE TYPE VEHICLES WILL BE PROVIDED WITH A MAP OF DEDICATION TO BE PROCESSED WITH THE FINAL MAP FOR "THE VILLAS AT MOUNTAIN SHADOWS CONDOMINIUMS".

A CONDOMINIUM UPON TRACT E OF "THE VILLAS AT MOUNTAIN SHADOWS II" AS RECORDED IN BOOK \_\_\_\_\_ OF MAPS AT PAGE \_\_\_\_ OF THE MARICOPA COUNTY RECORDERS OFFICE, AND SITUATED IN THE SE1/4 OF SECTION 8, T2N, R4E OF THE GILA AND SALT RIVER BASE AND MERIDIAN, MARICOPA COUNTY, ARIZONA

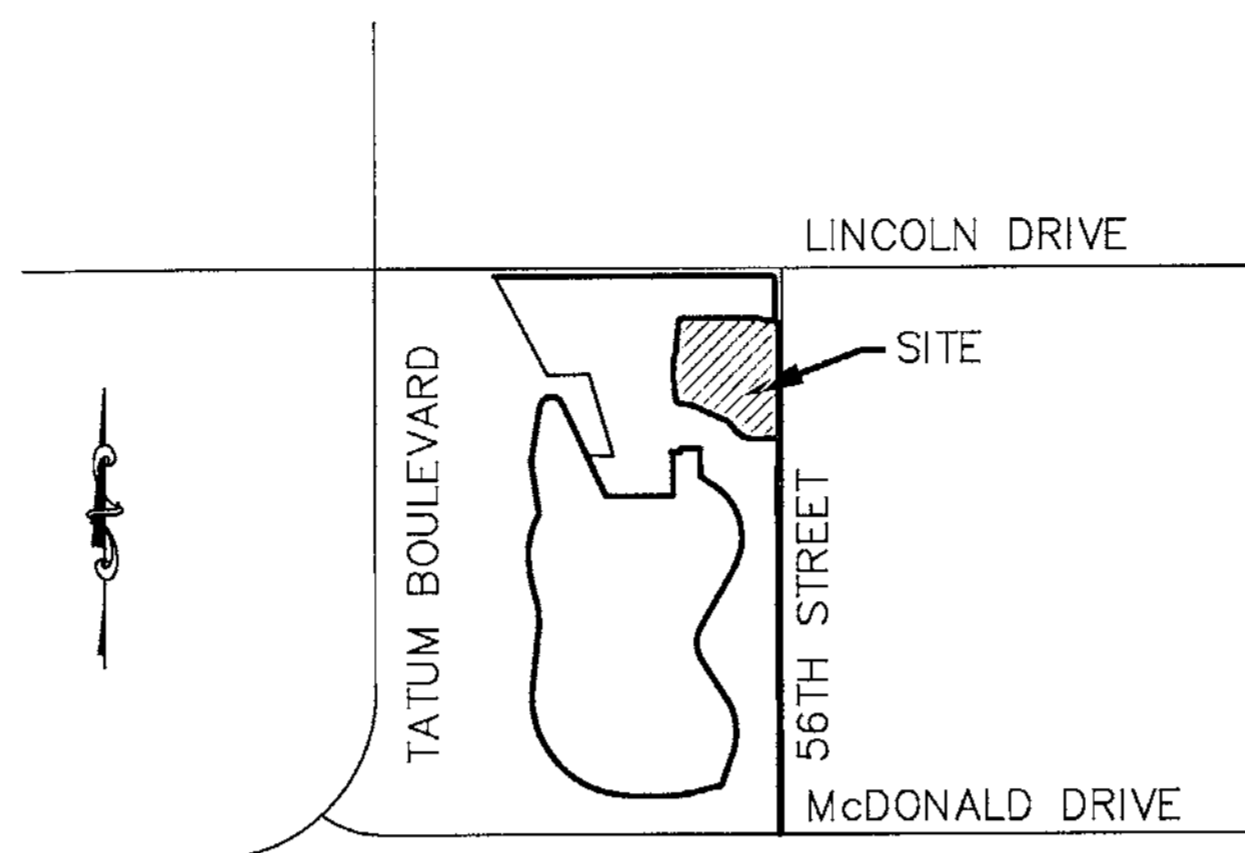

VICINITY MAP  
N.T.S.

## 100 YEAR ASSURED WATER SUPPLY

THE AREA PLATTED HEREON LIES WITHIN THE DOMESTIC WATER SERVICE AREA OF EPCOR WATER ARIZONA INC. - PARADISE VALLEY WHICH IS DESIGNATED AS HAVING AN ASSURED WATER SUPPLY PURSUANT TO SECTION 45-576 ARIZONA REVISED STATUTES AS PER ARIZONA DEPARTMENT OF WATER RESOURCES CERTIFICATE NUMBER \_\_\_\_\_ DATED \_\_\_\_\_

## DRAINAGE EASEMENT RESTRICTIONS

PURSUANT TO A.R.S. 9-463.01(C), AND ARTICLE 6-4(E)(J), 8-7-1 ET. SEQ., AND SECTION 6-3-8 OF THE CODE OF ORDINANCES OF THE TOWN OF PARADISE VALLEY, DRAINAGE EASEMENTS ARE FOR THE PURPOSE OF ALLOWING STORM, FLOOD AND OTHER WATERS TO PASS OVER, UNDER OR THROUGH THE LAND SET ASIDE FOR SUCH EASEMENTS, AND NOTHING WHICH MAY, TO ANY DEGREE, IMPEDE OR OBSTRUCT THE FLOW OF SUCH WATERS. SHALL BE CONSTRUCTED, PLACED, PLANTED, OR ALLOWED TO GROW ON OR IN SUCH EASEMENTS. THE MAINTENANCE AND CLEARING OF THESE DRAINAGE EASEMENTS SHALL BE THE SOLE RESPONSIBILITY AND DUTY OF THE OWNER OF THE PROPERTY ON WHICH SAID EASEMENTS ARE PLATTED. HOWEVER, THE TOWN OF PARADISE VALLEY, A MUNICIPAL CORPORATION, MAY, IF THE TOWN DEEMS IT TO BE IN THE BEST INTERESTS OF THE HEALTH, SAFETY, OR WELFARE OF THE TOWN OF PARADISE VALLEY, CONSTRUCT AND/OR MAINTAIN DRAINAGE FACILITIES ON OR UNDER SUCH EASEMENTS. AGENTS AND EMPLOYEES OF THE TOWN OF PARADISE VALLEY SHALL HAVE FREE ACCESS TO AND FROM ALL PORTIONS OF SUCH EASEMENTS AT ALL TIMES.

## UTILITY PROVIDERS

SEWER	CITY OF PHOENIX
WATER	EPCOR WATER
TELEPHONE	CENTURY LINK
CABLE	COX COMMUNICATIONS
GAS	SOUTHWEST GAS
ELECTRIC	ARIZONA PUBLIC SERVICE

## SITE DATA

EXISTING ZONING - S.U.P.- RESORT
TOTAL TRACTS - 1
TOTAL UNITS - 40
GROSS SITE AREA - 5.17 AC.
NET SITE AREA - 5.17 AC.

## LEGEND

BSL - BUILDING SETBACK LINE	G - GAS LINE
B/C - BACK OF CURB	S - SEWER LINE
C.A. - COMMON AREA	W - WATER LINE
E/P - EDGE OF PAVEMENT	△ - FND. OR SET MONUMENT AT SECTION CORNER
ESMT. - EASEMENT	⊙ - SUBDIVISION CORNER &/OR FND. OR SET MONUMENT AS NOTED
EXST. - EXISTING	⊕ - FIRE HYDRANT (EXISTING)
P.U.E. - PUBLIC UTILITY EASEMENT	⊕ - FIRE HYDRANT (PROPOSED)
U.E. - UTILITY EASEMENT	⊙ - SEWER MANHOLE (EXISTING OR PROPOSED)
TYP. - TYPICAL	TR - DENOTES TRUST
S.U.P.- SPECIAL USE PERMIT	MCR - DENOTES MARICOPA COUNTY RECORDS
M.A.G. - MARICOPA ASSOCIATION OF GOVERNMENTS	
STD. - STANDARD	
C - CABLE	
T - TELEPHONE	

## OWNER

MTS LAND, LLC, A DELEWARE LIMITED LIABILITY COMPANY  
4550 N. 12TH STREET  
PHOENIX, ARIZONA 85014  
PHONE: (602) 264-6831  
IRVINE, CA 92612  
PHONE: 949.476.2200  
CONTACT: ROBERT A. FLAXMAN, CEO

## ENGINEER

COE AND VAN LOO II L.L.C.  
4550 N. 12TH STREET  
PHOENIX, ARIZONA 85014  
PHONE: (602) 264-6831  
FAX: (602) 264-0928  
CONTACT: FRED E. FLEET P.E.  
EMAIL: FEF\_@CVLCI.COM

## SHEET INDEX

- DECLARATION & NOTES
- BOUNDARY MAP
- GROUND (1ST) LEVEL PLAN
- SECOND (2ND) LEVEL PLAN
- UNIT PLANS & VERTICAL SCHEMATIC
- PARKING PLAN

## BENCHMARK

W 1/4 CORNER OF SECTION 9, T.2.N., R.4.E.,  
FD BCHH ⊙ INTERSECTION OF 56TH STREET  
AND LINCOLN DRIVE.  
ELEVATION 1363.42 (NAVD 88' DATUM)

## MTS LAND LLC, A DELEWARE LIMITED LIABILITY COMPANY IN WITNESS WHEREOF:

MTS LAND, LLC, A DELAWARE LIMITED LIABILITY COMPANY, AS OWNER, HAS HEREUNTO CAUSED IT'S NAME TO BE AFFIXED HERETO AND THE SAME TO BE ATTESTED BY ROBERT A. FLAXMAN IT'S AUTHORIZED AGENT.

ROBERT A. FLAXMAN, AUTHORIZED AGENT DATE \_\_\_\_\_

## ACKNOWLEDGMENT:

STATE OF CALIFORNIA }  
COUNTY OF ORANGE } SS

ON \_\_\_\_\_, BEFORE ME, ANN M. VERA, A NOTARY PUBLIC, PERSONALLY APPEARED ROBERT A. FLAXMAN, WHO PROVED TO ME ON THE BASIS OF SATISFACTORY EVIDENCE TO BE THE PERSON WHOSE NAME IS SUBSCRIBED TO THE WITHIN INSTRUMENT AND ACKNOWLEDGED TO ME THAT HE EXECUTED THE SAME IN HIS AUTHORIZED CAPACITY, AND THAT BY HIS SIGNATURE ON THE INSTRUMENT THE PERSON, OR THE ENTITY UPON BEHALF OF WHICH THE PERSON ACTED, EXECUTED THE INSTRUMENT.

I CERTIFY UNDER PENALTY OF PERJURY UNDER THE LAWS OF THE STATE OF CALIFORNIA THAT THE FOREGOING PARAGRAPH IS TRUE AND CORRECT.

WITNESS MY HAND AND OFFICIAL SEAL

SIGNATURE: \_\_\_\_\_  
ANN M. VERA

## APPROVALS:

APPROVED BY THE TOWN COUNCIL OF THE TOWN OF PARADISE VALLEY THIS \_\_\_\_\_ DAY \_\_\_\_\_, 2015.

BY: \_\_\_\_\_  
MAYOR

ATTEST: \_\_\_\_\_  
TOWN CLERK

\_\_\_\_\_

\_\_\_\_\_

## CERTIFICATION

THIS IS TO CERTIFY THAT THE SURVEY OF THE PREMISES DESCRIBED AND MAPPED HEREON WAS MADE UNDER MY DIRECTION DURING THE MONTH OF OCTOBER 2015 AND THAT THIS SURVEY IS COMPLETE AS SHOWN, THAT THE MONUMENTS SHOWN ACTUALLY EXIST, THAT THEIR POSITIONS ARE CORRECTLY SHOWN, AND THAT SAID MONUMENTS ARE SUFFICIENT TO ENABLE THE SURVEY TO BE RETRACED.

REGISTERED LAND SURVEYOR

NO.	REVISION	DATE

**PRELIMINARY MAP**  
 THE VILLAS AT MOUNTAIN SHADOWS CONDOMINIUMS  
 PARADISE VALLEY, ARIZONA

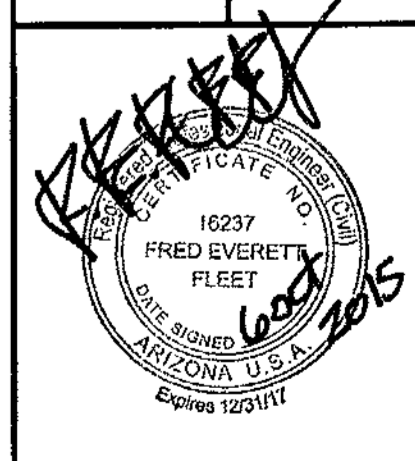

SHEET NUMBER  
1 OF 6



CVL Department: Land  
CVL Project #: 01-0245801  
CVL File:

# PRELIMINARY MAP "THE VILLAS AT MOUNTAIN SHADOWS CONDOMINIUMS"

A CONDOMINIUM UPON TRACT E OF "THE VILLAS AT MOUNTAIN SHADOWS II" AS RECORDED IN BOOK \_\_\_\_\_ OF MAPS AT PAGE \_\_\_\_ OF THE MARICOPA COUNTY RECORDERS OFFICE, AND SITUATED IN THE SE1/4 OF SECTION 8, T2N, R4E OF THE GILA AND SALT RIVER BASE AND MERIDIAN, MARICOPA COUNTY, ARIZONA

## BOUNDARY MAP

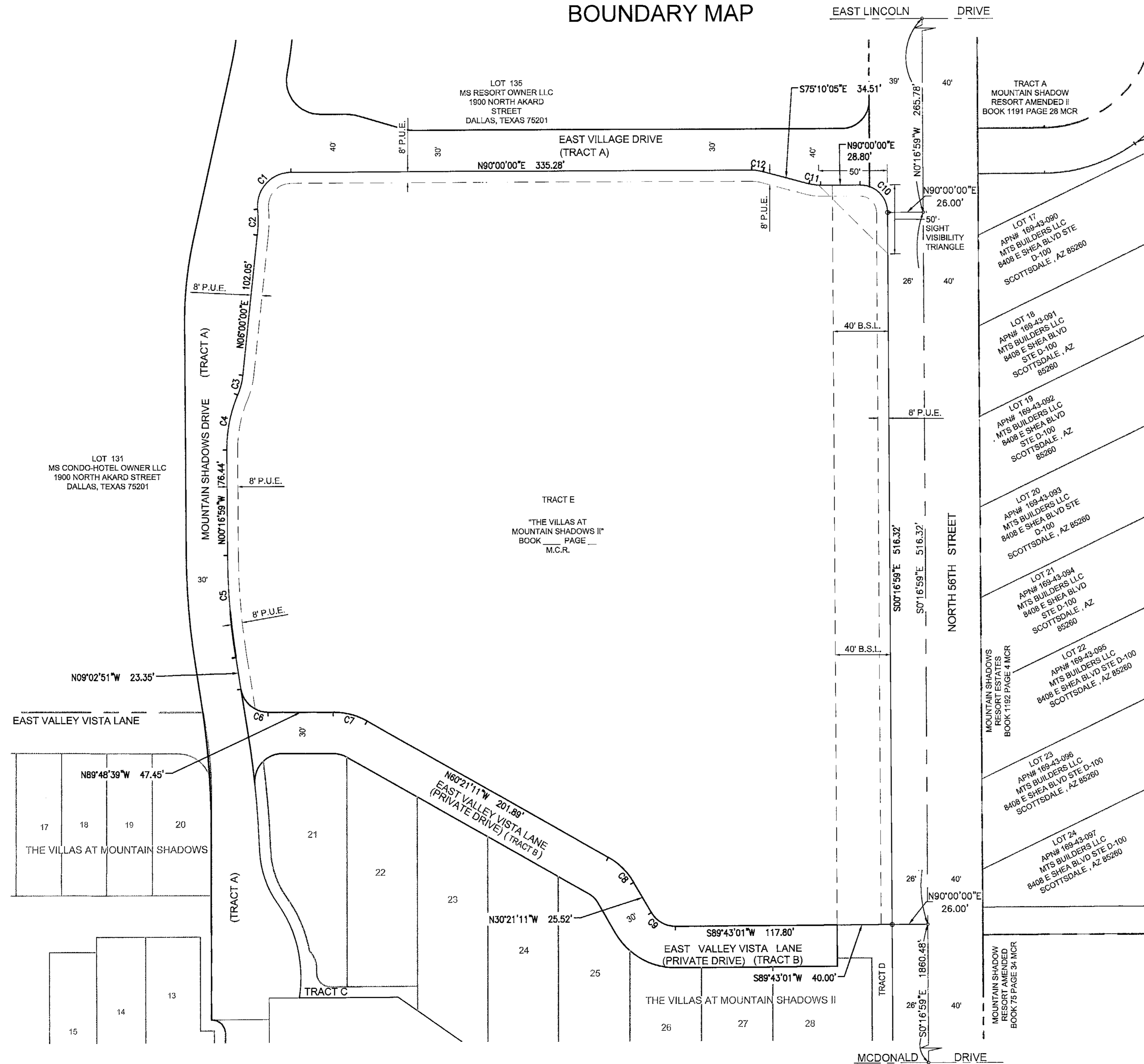

CURVE TABLE						
NO.	ARC	RADIUS	DELTA	TANGENT	CHORD	CHORD-BEARING
C1	40.53	24.50	094°47'15"	26.64	36.07	N42°36'23"E
C2	18.83	100.00	010°47'15"	9.44	18.80	N00°36'23"E
C3	14.97	50.00	017°09'27"	7.54	14.92	N14°34'44"E
C4	40.91	100.00	023°26'26"	20.75	40.63	N11°26'14"E
C5	74.19	485.00	008°45'52"	37.17	74.12	N04°39'55"W
C6	28.19	20.00	080°45'48"	17.01	25.92	N49°25'45"W
C7	25.71	50.00	029°27'28"	13.14	25.42	N75°04'55"W
C8	26.18	50.00	030°00'00"	13.40	25.88	N45°21'11"W
C9	20.92	20.00	059°55'48"	11.53	19.98	N60°19'05"W
C10	31.32	20.00	089°43'01"	19.90	28.21	S45°08'29"E
C11	8.41	32.50	014°49'55"	4.23	8.39	S82°35'02"E
C12	8.41	32.50	014°49'55"	4.23	8.39	S82°35'02"E

NO.	REVISION	DATE

**PRELIMINARY MAP**  
THE VILLAS AT MOUNTAIN SHADOWS CONDOMINIUMS  
PARADISE VALLEY, ARIZONA



SHEET NUMBER  
**2 OF 6**

CVL Department, Land  
CVL Project #: 01-0245801  
CVL File:

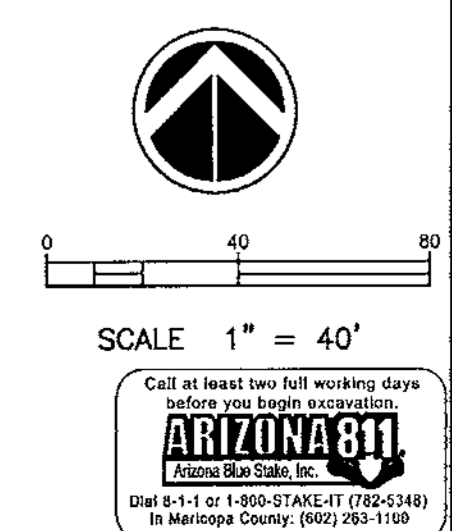

Printed By: Julliv Printed Date: October 6, 2015 File Name: N:\010245801\CAD\DWG\EST\Condo\preliminary\PS.PRE.CONDO.MAP.01-05.093015.dwg

**CVL CONSULTANTS**  
4550 North 12th Street  
Phoenix, Arizona 85014  
602-264-6831  
www.cvlci.com

**Coe and Van Loo II L.L.C.**

PROJECT NO. XXXXXX

# PRELIMINARY MAP

## "THE VILLAS AT MOUNTAIN SHADOWS CONDOMINIUMS"

A CONDOMINIUM UPON TRACT E OF "THE VILLAS AT MOUNTAIN SHADOWS II" AS RECORDED IN BOOK \_\_\_\_\_ OF MAPS AT PAGE \_\_\_\_\_ OF THE MARICOPA COUNTY RECORDERS OFFICE, AND SITUATED IN THE SE1/4 OF SECTION 8, T2N, R4E OF THE GILA AND SALT RIVER BASE AND MERIDIAN, MARICOPA COUNTY, ARIZONA

### GROUND (1ST) LEVEL PLAN

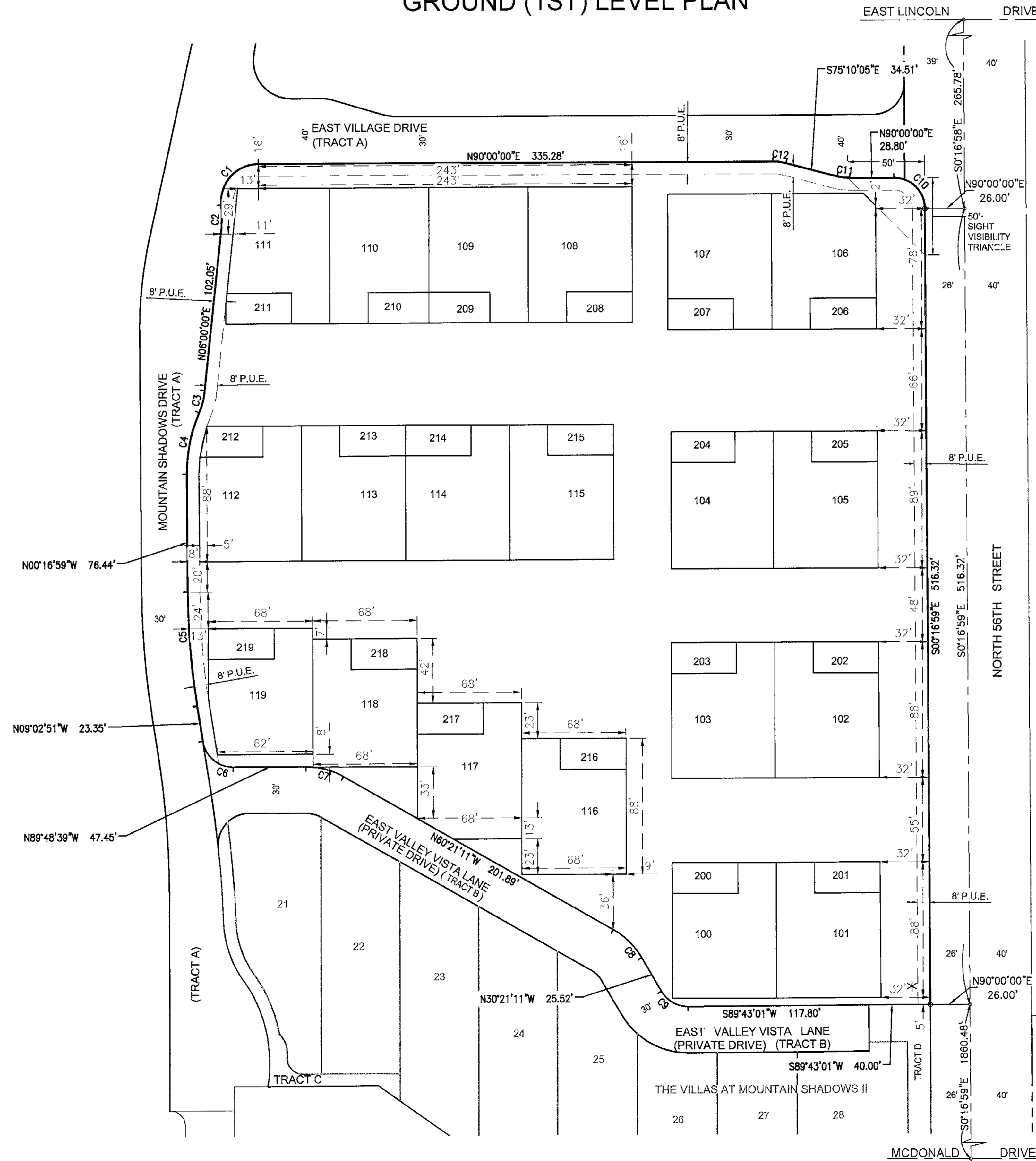

\* DENOTES SET BACK FROM PROPERTY LINE TO LIMITS OF PATIO AND OR BALCONY AIR SPACE

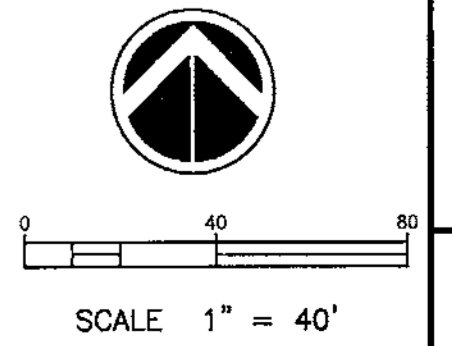

NO.	REVISION	DATE

**PRELIMINARY MAP**

THE VILLAS AT MOUNTAIN SHADOWS CONDOMINIUMS  
PARADISE VALLEY, ARIZONA

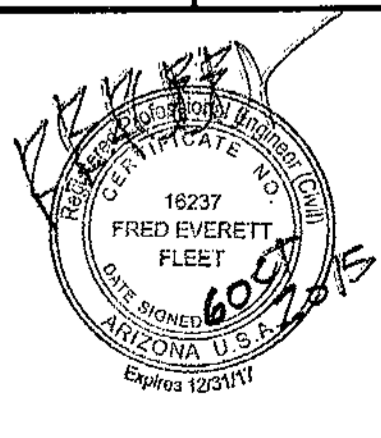

SHEET NUMBER  
**3 OF 6**

CIVL Department: Land  
CIVL Project #: 01-0245501  
CIVL File:

**CVL**  
CONSULTANTS

4550 North 12th Street  
Phoenix, Arizona 85014  
602-264-6831  
www.cvlci.com

**Coe and Van Loo II L.L.C.**

PROJECT NO. XXXXXXX

# PRELIMINARY MAP

## "THE VILLAS AT MOUNTAIN SHADOWS CONDOMINIUMS"

A CONDOMINIUM UPON TRACT E OF "THE VILLAS AT MOUNTAIN SHADOWS II" AS RECORDED IN BOOK \_\_\_\_\_ OF MAPS AT PAGE \_\_\_ OF THE MARICOPA COUNTY RECORDERS OFFICE, AND SITUATED IN THE SE1/4 OF SECTION 8, T2N, R4E OF THE GILA AND SALT RIVER BASE AND MERIDIAN, MARICOPA COUNTY, ARIZONA

### SECOND (2ND) LEVEL PLAN

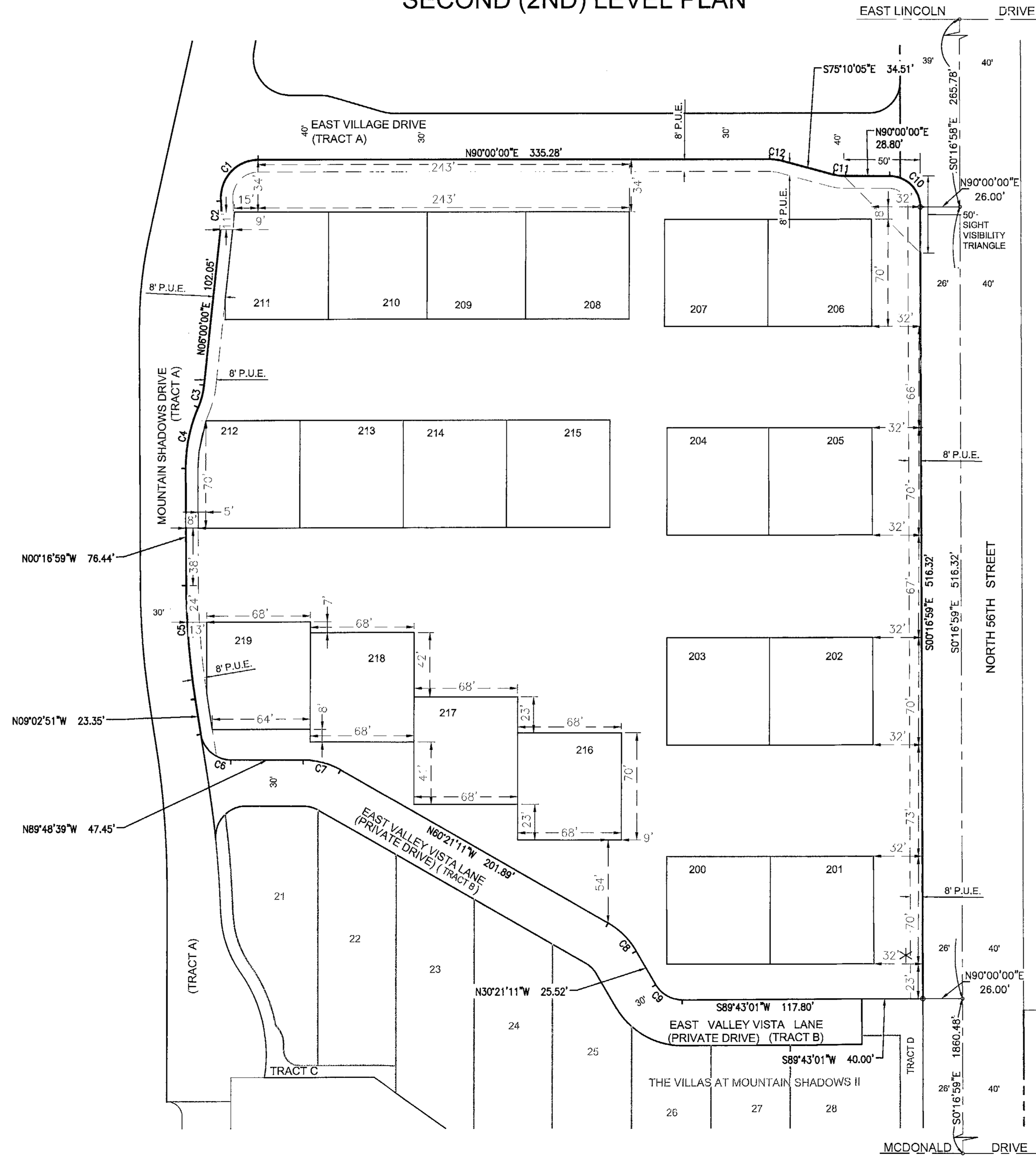

\* DENOTES SET BACK FROM PROPERTY LINE TO LIMITS OF PATIO AND OR BALCONY AIR SPACE

SCALE 1" = 40'

NO.	REVISION	DATE

**PRELIMINARY MAP**

THE VILLAS AT MOUNTAIN SHADOWS CONDOMINIUMS  
PARADISE VALLEY, ARIZONA

FRED EVERETT FLEET  
16237  
ARIZONA U.S.A.  
Paradise Valley

**SHEET NUMBER**  
**4 OF 6**

CVL Department: Land  
CVL Project #: 01-0245901  
CVL File:

PRELIMINARY MAP  
**"THE VILLAS AT MOUNTAIN SHADOWS CONDOMINIUMS"**

A CONDOMINIUM UPON TRACT E OF "THE VILLAS AT MOUNTAIN SHADOWS II" AS RECORDED IN BOOK \_\_\_\_\_ OF MAPS AT PAGE \_\_\_\_ OF THE MARICOPA COUNTY RECORDERS OFFICE, AND SITUATED IN THE SE1/4 OF SECTION 8, T2N, R4E OF THE GILA AND SALT RIVER BASE AND MERIDIAN, MARICOPA COUNTY, ARIZONA

**UNIT PLANS & VERTICAL SCHEMATIC**

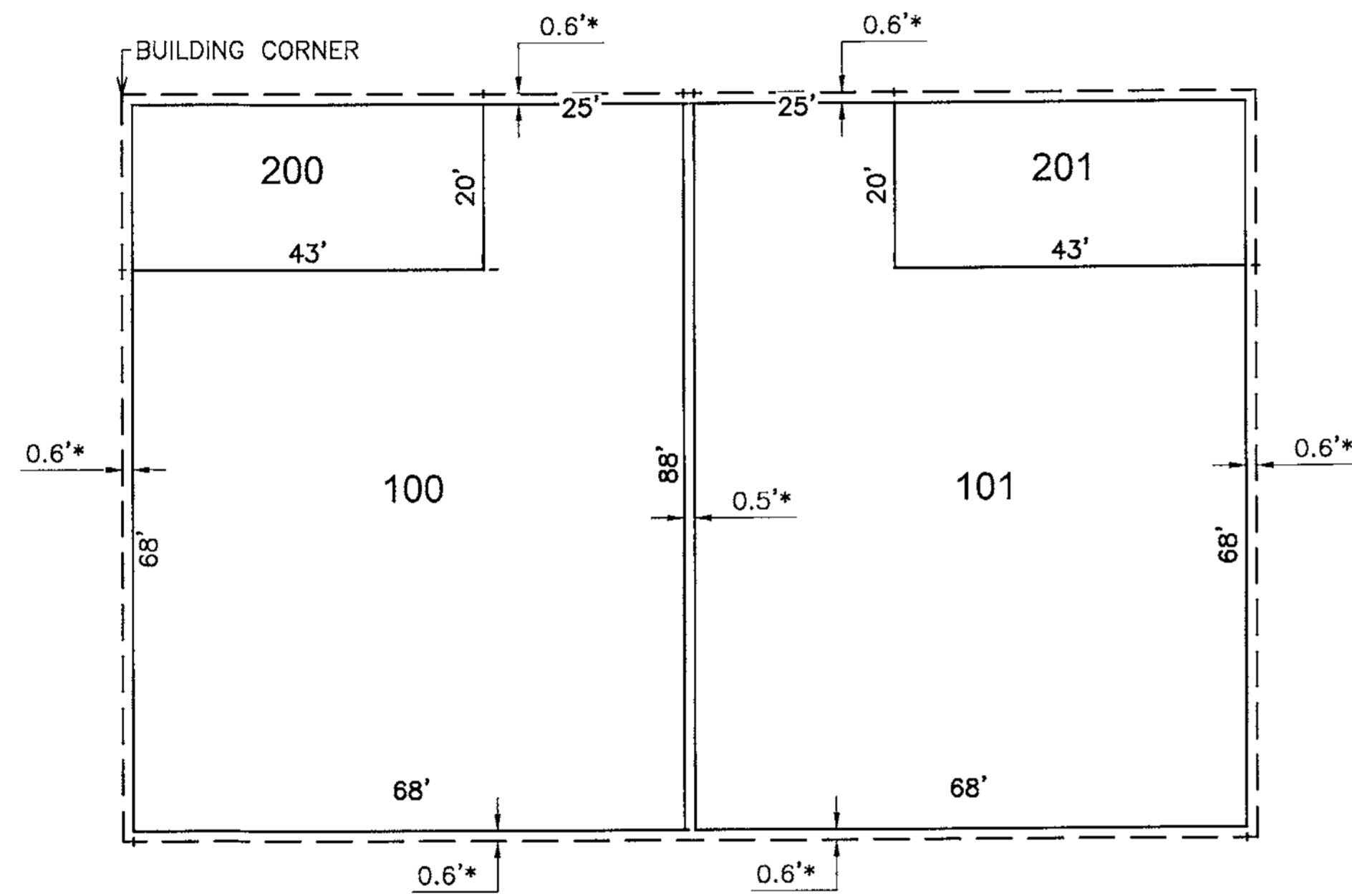

TYPICAL FIRST LEVEL PLAN  
 N.T.S.

UNIT NUMBER	LOWER UNIT BOUNDARY	UPPER UNIT BOUNDARY
100		
101		
102		
103		
104		
105		
106		
107		
108		
109		
110		
111		
112		
113		
114		
115		
116		
117		
118		
119		

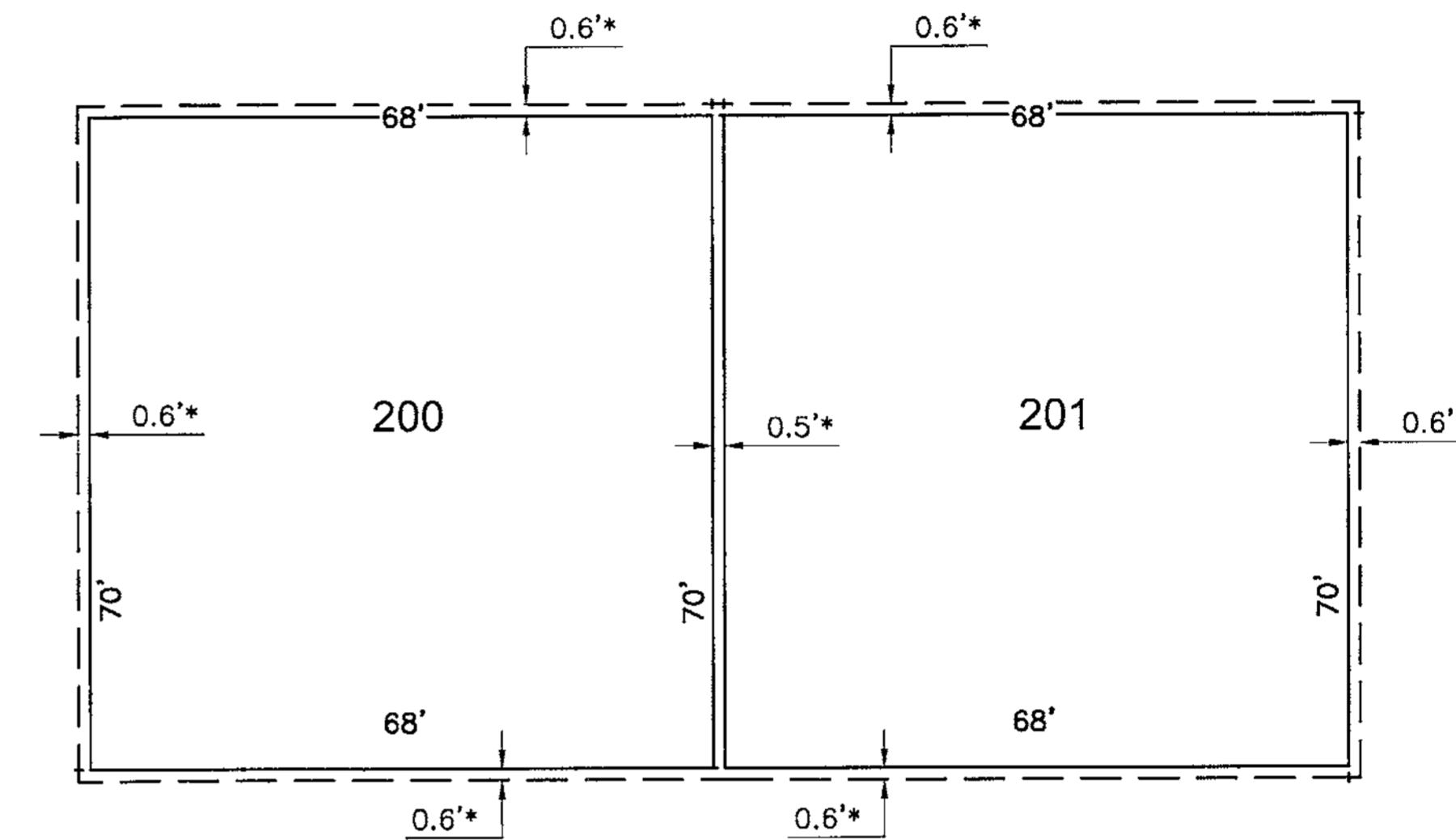

TYPICAL SECOND LEVEL PLAN  
 N.T.S.

UNIT NUMBER	LOWER UNIT BOUNDARY	UPPER UNIT BOUNDARY
200		
201		
202		
203		
204		
205		
206		
207		
208		
209		
210		
211		
212		
213		
214		
215		
216		
217		
218		
219		

**LEGEND**

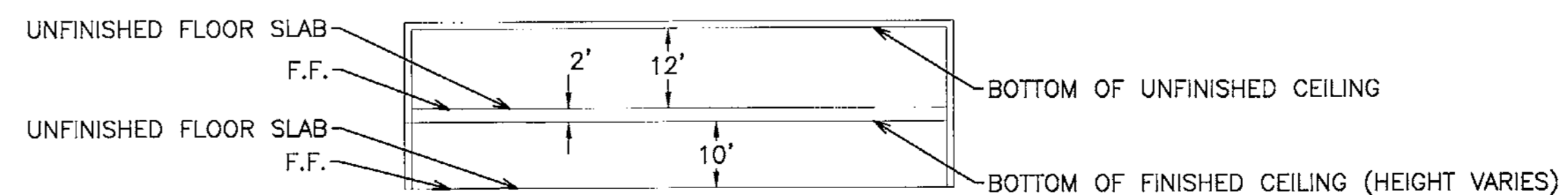

- INTERIOR BOUNDARY
- - - EXTERIOR FACE / COMMON WALL
- F.F. — FINISHED FLOOR
- 0.5'\* — COMMON / INTERIOR WALL DIMENSION
- 0.6'\* — COMMON / EXTERIOR WALL DIMENSION



VERTICAL SCHEMATIC  
 N.T.S.

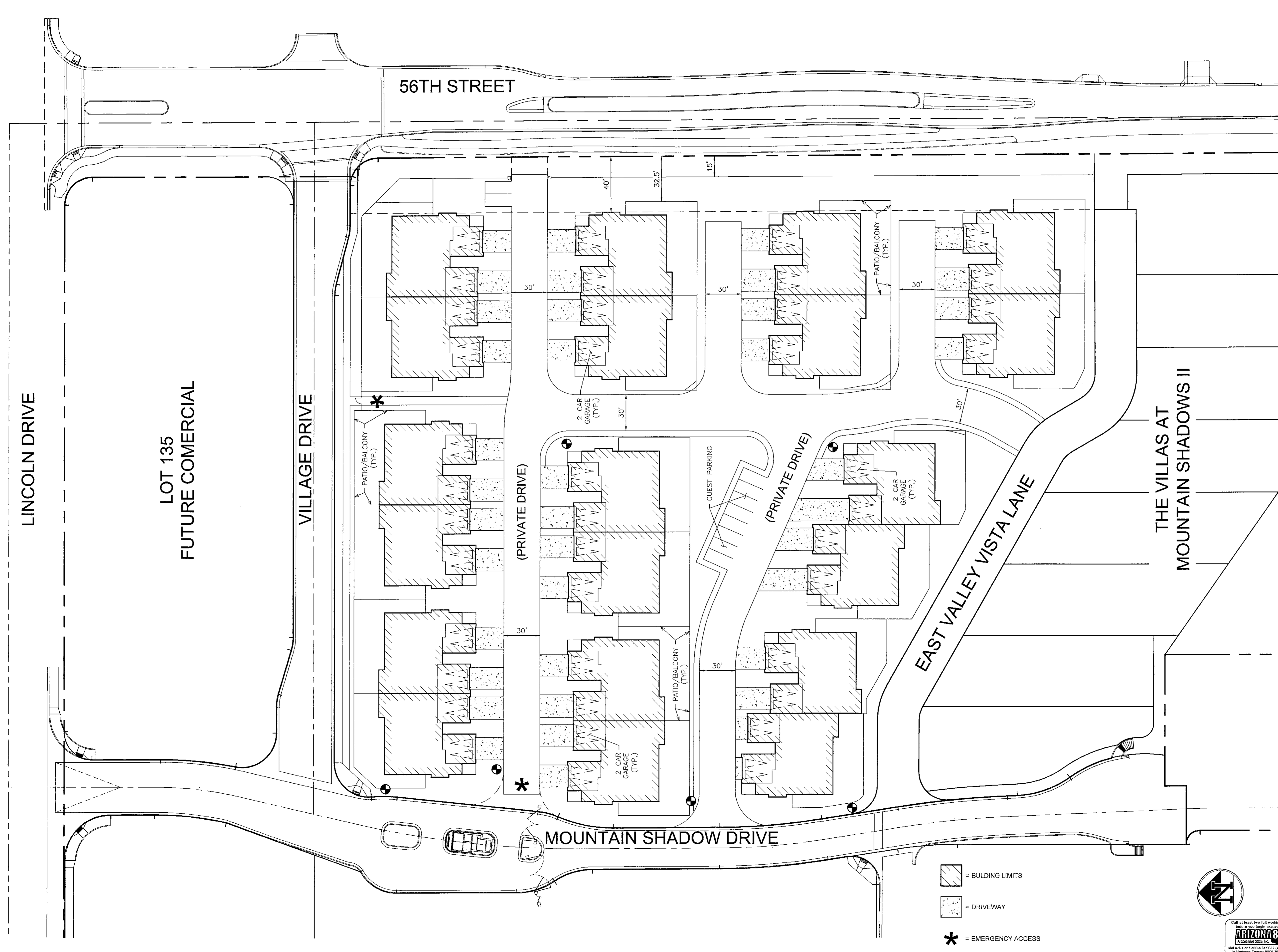



-  = BUILDING LIMITS
-  = DRIVEWAY
-  = EMERGENCY ACCESS

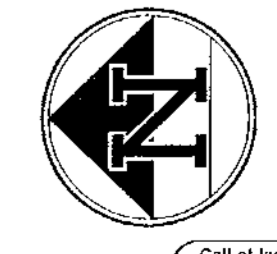

NO.	REVISION	DATE

**PRELIMINARY MAP**

THE VILLAS AT MOUNTAIN SHADOWS CONDOMINIUMS  
PARADISE VALLEY, ARIZONA

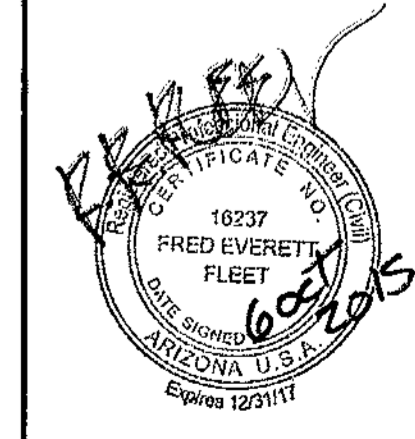

SHEET NUMBER  
**6 OF 6**

CVL Department: Land  
CVL Project #: 01-0245901  
CVL File:

**Coe and Van Loo II L.L.C.**