

FINAL PLAT FOR THE VILLAS AT MOUNTAIN SHADOWS - AMENDED - CONDOMINIUMS

A CONDOMINIUM PLAT UPON TRACTS C AND E OF "THE VILLAS AT MOUNTAIN SHADOWS - AMENDED" AS RECORDED IN BOOK ____ OF MAPS, PAGE __, M.C.R., AND SITUATED IN THE SOUTHEAST QUARTER OF SECTION 8, TOWNSHIP 2 NORTH, RANGE 4 EAST OF THE GILA AND SALT RIVER BASE AND MERIDIAN MARICOPA COUNTY, ARIZONA

COUNTY RECORDER

CVL CONSULTANTS
4550 North 12th Street
Phoenix, Arizona 85014
602-264-6831
www.cvlci.com

NOTES

- THE BOUNDARIES OF EACH UNIT ARE AS FOLLOWS PER THE CONVENANTS, CONDITIONS & RESTRICTIONS (CC&R'S):
 - THE VERTICAL BOUNDARIES ARE THE INTERIOR FINISHED SURFACES OF THE PERIMETER WALLS OF THE UNIT;
 - THE LOWER HORIZONTAL BOUNDARY IS THE TOP SURFACE OF THE FLOOR SLAB BENEATH THE UNIT; AND
 - THE UPPER AND LOWER HORIZONTAL BOUNDARIES OF EACH UNIT SHALL BE FROM THE UNFINISHED FLOOR OR EACH UNIT TO THE UNFINISHED CEILING OF EACH UNIT.
 - COLUMNS AND SHAFTS ARE EXEMPT FROM BUILDING, UNITS, STORAGE AND PARKING DIMENSIONS.
- COMMON ELEMENTS (C.E.) AND LIMITED COMMON ELEMENTS (L.C.E.) ARE MORE FULLY DESCRIBED IN THE DECLARATION OF A CONDOMINIUM FOR "THE VILLAS AT MOUNTAIN SHADOWS - AMENDED - CONDOMINIUM", A CONDOMINIUM TO BE RECORDED FOLLOWING THE RECORDING OF THIS PLAT.
- TIES SHOWN ARE TO OUTSIDE FACE OF BUILDINGS (GROUND LEVEL).
- NO POWER POLES EXIST ON-SITE.
- BUILDING HEIGHT WILL COMPLY WITH THE MOUNTAIN SHADOWS RESORT "SPECIAL USE PERMIT - RESORT" REQUIREMENTS.

OWNER

TNHC MOUNTAIN SHADOWS, LLC. A DELAWARE LIMITED LIABILITY COMPANY
6730 N. SCOTTSDALE ROAD, SUITE 235
SCOTTSDALE, AZ 85253
PHONE: (480) 634-0497
CONTACT: JOHN P. MORONEY, PRESIDENT

ARCHITECT

JZMK PARTNERS
3080 BRISTOL STREET, SUITE 650
COSTA MESA, CALIFORNIA 92626
PHONE: (714) 428-6900
CONTACT: BRYAN STADLER

ENGINEER

COE & VAN LOO CONSULTANTS, INC.
4550 NORTH 12TH STREET
PHOENIX, ARIZONA 85014
PHONE: (602) 264-6831
FAX: (602) 264-0928
CONTACT: FRED E. FLEET, P.E., F.A.S.C.E.

UTILITY PROVIDERS

| | |
|-----------|------------------------|
| SEWER | CITY OF PHOENIX |
| WATER | EPCOR WATER |
| TELEPHONE | CENTURYLINK |
| CABLE | COX COMMUNICATIONS |
| GAS | SOUTHWEST GAS |
| ELECTRIC | ARIZONA PUBLIC SERVICE |

LEGEND

- ▲--- INDICATES SECTION CORNER - FOUND BRASS CAP (UNLESS OTHERWISE NOTED)
- INDICATES FOUND 1/2" REBAR WITH CAP RLS #22782 (UNLESS OTHERWISE NOTED)
- INDICATES INTERIOR BOUNDARY
- INDICATES EXTERIOR FACE
- INDICATES FLOOR LIMITS
- INDICATES OPEN TO FLOOR BELOW
- INDICATES LIMITS OF TERRACE
- ① INDICATES SHEET NUMBER
- * INDICATES LOFT UNIT
- U.E. INDICATES UTILITY EASEMENT PER BOOK 1232 OF MAPS, PAGE 27, M.C.R.
- C1 INDICATES CURVE NUMBER
- S.F. INDICATES SQUARE FEET
- C.E. INDICATES COMMON ELEMENT
- L.C.E. INDICATES LIMITED COMMON ELEMENT
- P11 INDICATES DESIGNATED PARKING SPACE NUMBER
- U11 INDICATES DESIGNATED STORAGE ROOM NUMBER
- L.B.E. INDICATES LOWER BOUNDARY ELEVATION
- U.B.E. INDICATES UPPER BOUNDARY ELEVATION

SHEET INDEX

- 1 COVER SHEET, DEDICATION, NOTES
- 2 BOUNDARY MAP
- 3 FIRST LEVEL PLAN
- 4 SECOND LEVEL PLAN
- 5-6 UNIT PLANS & VERTICAL SCHEMATICS

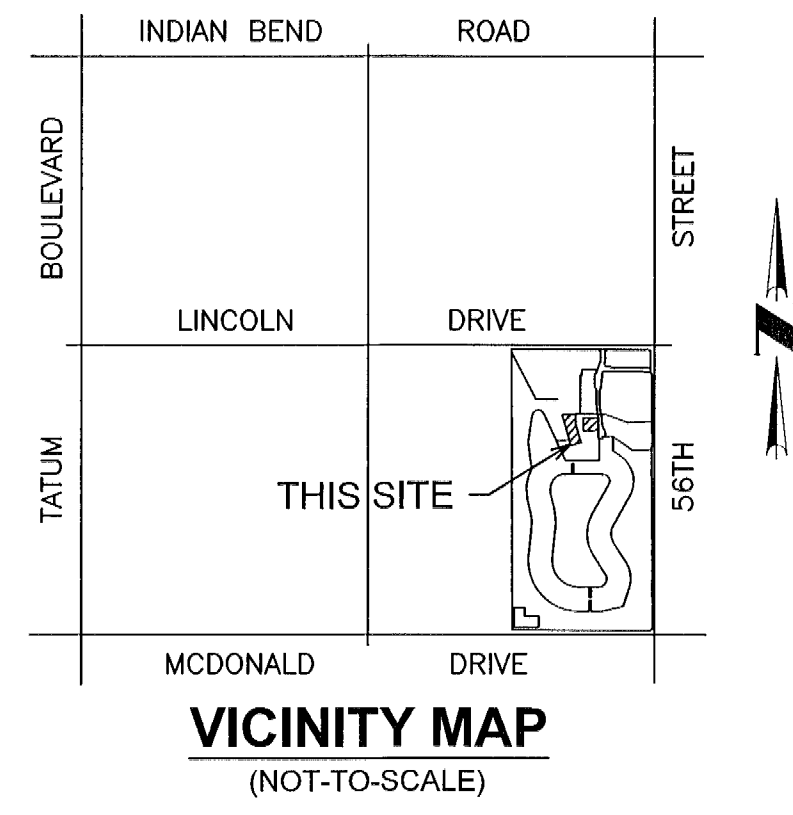

DEDICATION

STATE OF ARIZONA)
COUNTY OF MARICOPA) SS

KNOW ALL MEN BY THESE PRESENTS:

THAT TNHC MOUNTAIN SHADOWS, LLC. A DELAWARE LIMITED LIABILITY COMPANY, AS OWNER, HAS SUBDIVIDED UNDER THE NAME OF "THE VILLAS AT MOUNTAIN SHADOWS - AMENDED - CONDOMINIUMS" A CONDOMINIUM UPON TRACTS 'C' AND 'E' OF "THE VILLAS AT MOUNTAIN SHADOWS - AMENDED" AS RECORDED IN BOOK ____ OF MAPS, PAGE __, M.C.R. AND SITUATED IN THE SOUTHEAST QUARTER OF SECTION 8, TOWNSHIP 2 NORTH, RANGE 4 EAST, OF THE GILA AND SALT RIVER BASE AND MERIDIAN, MARICOPA COUNTY, ARIZONA, AS SHOWN PLATTED HEREON AND HEREBY PUBLISHES THIS FINAL PLAT AND DECLARES THAT THIS PLAT SETS FORTH THE LOCATION AND GIVES THE DIMENSIONS OF THE BOUNDARIES OF THE CONDOMINIUM UNITS, AND THAT EACH UNIT SHALL BE KNOWN BY THE NUMBER GIVEN EACH RESPECTIVELY ON SAID PLAT.

IN WITNESS WHEREOF:

TNHC MOUNTAIN SHADOWS, LLC. A DELAWARE LIMITED LIABILITY COMPANY, AS OWNER OF THE LAND DESCRIBED HEREIN, HAS CAUSED ITS NAME TO BE AFFIXED AND THE SAME TO BE ATTESTED BY THE SIGNATURE OF THE UNDERSIGNED DULY AUTHORIZED OFFICER.

TNHC MOUNTAIN SHADOWS, LLC. A DELAWARE LIMITED LIABILITY COMPANY
BY: _____ DATE: _____
JOHN P. MORONEY, PRESIDENT
ITS: AUTHORIZED SIGNATORY

ACKNOWLEDGEMENT

STATE OF ARIZONA)
COUNTY OF MARICOPA) SS

ON THIS ____ DAY OF _____, 2016, BEFORE ME, THE UNDERSIGNED NOTARY PUBLIC IN AND FOR SAID STATE, PERSONALLY APPEARED

_____, PERSONALLY KNOWN TO ME (OR PROVED TO ME ON THE BASIS OF SATISFACTORY EVIDENCE) TO BE THE PERSON WHOSE NAME IS SUBSCRIBED TO THE WITHIN INSTRUMENT AND ACKNOWLEDGED TO ME THAT HE/SHE EXECUTED THE SAME IN HIS/HER AUTHORIZED CAPACITY, AND THAT BY HIS/HER SIGNATURE ON THE INSTRUMENT THE PERSON, OR THE ENTITY UPON BEHALF OF WHICH THE PERSON ACTED, EXECUTED THE INSTRUMENT.

WITNESS MY HAND AND OFFICIAL SEAL

NOTARY PUBLIC _____

APPROVAL

APPROVED BY THE TOWN COUNCIL OF THE TOWN OF PARADISE VALLEY, ARIZONA THIS ____ DAY OF _____, 2016.

BY: _____ MAYOR

ATTEST: _____ TOWN CLERK

TOWN ENGINEER

PLANNING DIRECTOR

CERTIFICATION

I, LARRY E. SULLIVAN, HEREBY CERTIFY THAT I AM A REGISTERED LAND SURVEYOR IN THE STATE OF ARIZONA, THAT THIS MAP, CONSISTING OF SIX (6) SHEETS, CORRECTLY REPRESENTS A BOUNDARY SURVEY MADE UNDER MY SUPERVISION DURING THE MONTH OF JUNE, 2016, THAT THE SURVEY IS TRUE AND COMPLETE AS SHOWN, THAT ALL MONUMENTS SHOWN ACTUALLY EXIST OR WILL BE SET AS SHOWN, THAT THEIR POSITIONS ARE CORRECTLY SHOWN AND THAT SAID MONUMENTS ARE SUFFICIENT TO ENABLE THE SURVEY TO BE RETRACED.

BY: Larry E. Sullivan
LARRY E. SULLIVAN
REGISTRATION NUMBER 22782
4550 N. 12TH STREET
PHOENIX, ARIZONA 85014
(602)-264-6831
CVLSURVEY@CVLCCI.COM

DATE: _____
REVISION: _____
NO. _____
Coe and Van Loo II L.L.C.

FINAL PLAT
THE VILLAS AT MOUNTAIN SHADOWS - AMENDED -
CONDOMINIUM
PARADISE VALLEY, ARIZONA



DRAINAGE EASEMENT RESTRICTIONS

PURSUANT TO A.R.S. 9-463.01 (C), AND SECTION 6-4 (E)(J), 8-7-1 ET. SEQ. AND 6-3-8 OF THE CODE OF ORDINANCES OF THE TOWN OF PARADISE VALLEY, DRAINAGE EASEMENTS ARE FOR THE PURPOSE OF ALLOWING STORM, FLOOD AND OTHER WATERS TO PASS OVER, UNDER, OR THROUGH THE LAND SET ASIDE FOR SUCH EASEMENTS, AND NOTHING WHICH MAY, TO ANY DEGREE, IMPEDE OR OBSTRUCT THE FLOW OF SUCH WATER, SHALL BE CONSTRUCTED, PLACED, PLANTED OR ALLOWED TO GROW ON OR IN SUCH EASEMENTS. THE MAINTENANCE AND CLEARING OF THESE DRAINAGE EASEMENTS SHALL BE THE SOLE RESPONSIBILITY AND DUTY OF THE OWNER OF THE PROPERTY ON WHICH SAID EASEMENTS ARE PLATTED. HOWEVER, IF THE TOWN DEEMS IT TO BE IN THE BEST INTERESTS OF THE HEALTH, SAFETY, OR WELFARE OF THE TOWN OF PARADISE VALLEY, THE TOWN OF PARADISE VALLEY MAY CONSTRUCT AND/OR MAINTAIN DRAINAGE FACILITIES ON OR UNDER SUCH EASEMENTS. AGENTS AND EMPLOYEES OF THE TOWN OF PARADISE VALLEY SHALL HAVE FREE ACCESS TO AND FROM ALL PORTIONS OF SUCH EASEMENTS AT ALL TIMES.

100 YEAR ASSURED WATER SUPPLY

THE AREA PLATTED HEREON LIES WITHIN THE DOMESTIC WATER SERVICE AREA OF EPCOR - PARADISE VALLEY, WHICH IS DESIGNATED AS HAVING AN ASSURED WATER SUPPLY PURSUANT TO SECTION 45-576 ARIZONA REVISED STATUTES AS PER ARIZONA DEPARTMENT OF WATER RESOURCES CERTIFICATE NUMBER 29-700839.0001 DATED MARCH 18, 2016.

BASIS OF BEARING

THE BASIS OF BEARING FOR THIS SURVEY IS NORTH 00°16'59" WEST ALONG THE EAST LINE OF THE SOUTHEAST QUARTER OF SECTION 8, TOWNSHIP 2 NORTH, RANGE 4 EAST OF THE GILA AND SALT RIVER MERIDIAN, MARICOPA COUNTY, ARIZONA.

BENCHMARK

EAST 1/4 CORNER OF SECTION 8, TOWNSHIP 2 NORTH, RANGE 4 EAST TOWN OF PARADISE VALLEY BRASS CAP IN HANDHOLE LOCATED AT THE INTERSECTION OF 56TH STREET & LINCOLN
ELEVATION = 1363.42 (NAVD 88)
MCDOT GDACS NO. 24534-1
N: 20751.98, E: 86642.68

SITE DATA

| | |
|-----------------|-----------------|
| EXISTING ZONING | S.U.P. - RESORT |
| TOTAL UNITS | 12 |

GROSS AREA = 1.001 ACRES SEE SHEET 1 FOR LEGEND AND SEE SHEET 2 FOR CURVE TABLE

1 SHEET OF 6
CVL Contact: F. FLEET
CVL Project #: 14-0245826
CVL File #:

Printed By: VeennetaJ Print Date: May 5, 2016 File Name: N:\01024580\CADD\WEST\Residential-NHR1\DS.NHR1\FPLAT.02.dwg

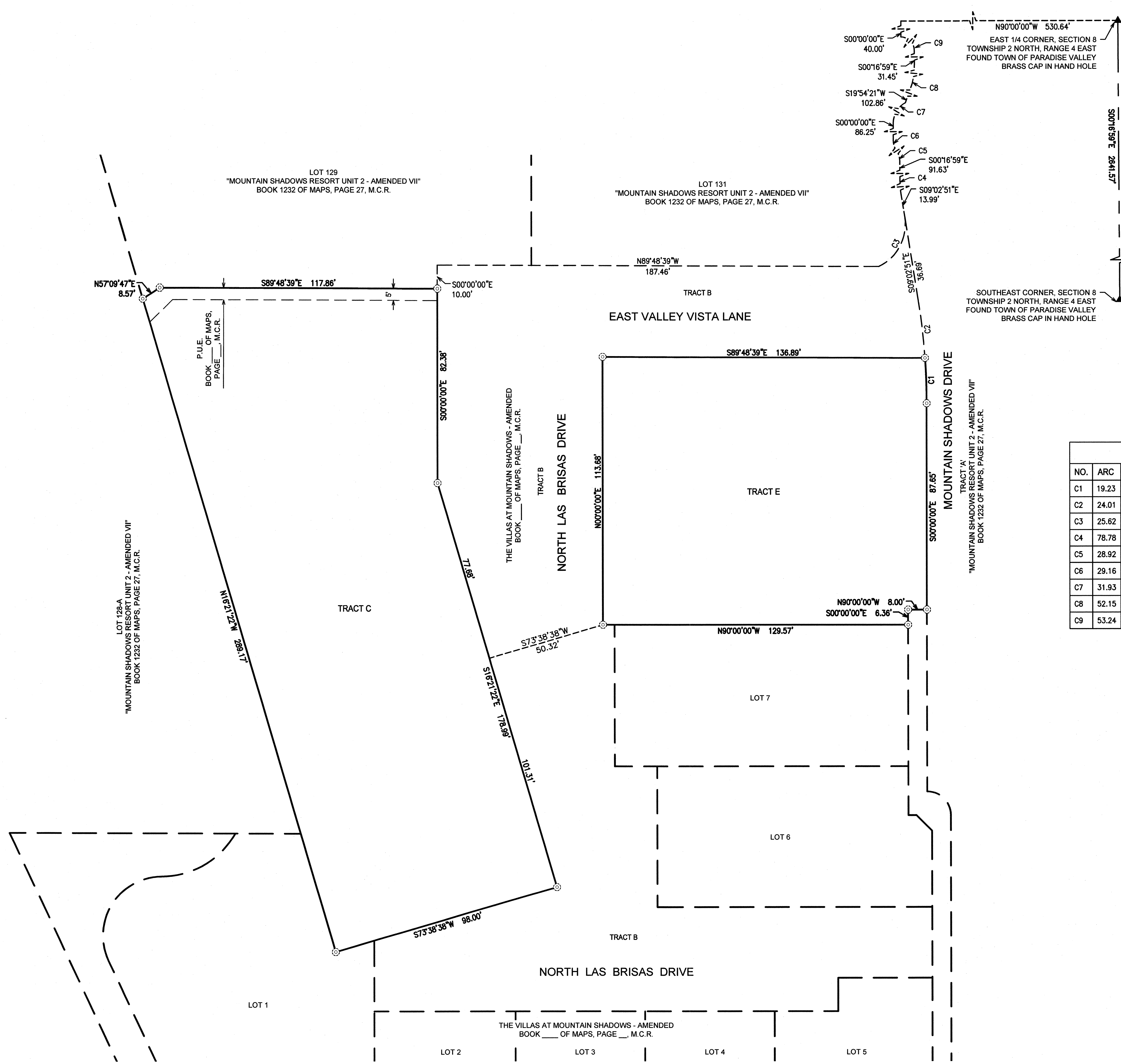

COUNTY RECORDER

| CURVE TABLE | | | | | | |
|-------------|-------|--------|------------|---------|-------|---------------|
| NO. | ARC | RADIUS | DELTA | TANGENT | CHORD | CHORD-BEARING |
| C1 | 19.23 | 273.82 | 004°01'28" | 9.62 | 19.23 | N02°00'44"W |
| C2 | 24.01 | 273.82 | 005°01'23" | 12.01 | 24.00 | N06°32'09"W |
| C3 | 25.62 | 20.00 | 073°23'42" | 14.91 | 23.90 | N27°39'00"E |
| C4 | 78.78 | 515.00 | 008°45'52" | 39.47 | 78.70 | S04°39'55"E |
| C5 | 28.92 | 50.00 | 033°08'06" | 14.87 | 28.51 | N16°51'02"W |
| C6 | 29.16 | 50.00 | 033°25'04" | 15.01 | 28.75 | S16°42'32"E |
| C7 | 31.93 | 30.00 | 060°58'28" | 17.66 | 30.44 | S30°29'14"W |
| C8 | 52.15 | 235.00 | 012°42'54" | 26.18 | 52.04 | N06°04'28"E |
| C9 | 53.24 | 34.00 | 089°43'01" | 33.83 | 47.96 | N45°08'29"W |

CVL
CONSULTANTS
4550 North 12th Street
Phoenix, Arizona 85014
602-264-6831
www.cvlci.com

DATE _____
REVISION _____
NO. _____
Coe and Van Loo II L.L.C.

FINAL PLAT
THE VILLAS AT MOUNTAIN SHADOWS - AMENDED -
CONDOMINIUM
PARADISE VALLEY, ARIZONA

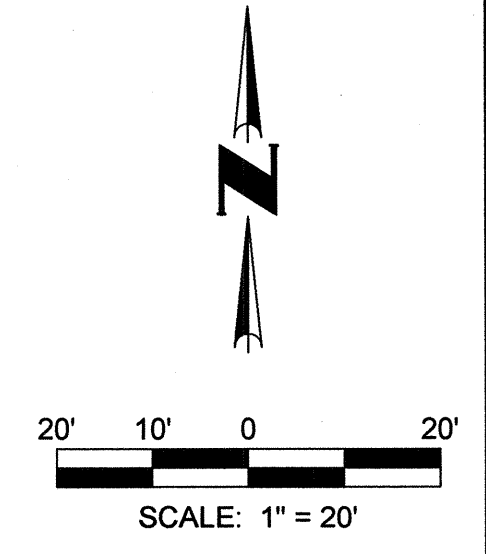

BOUNDARY PLAN SEE SHEET 1 FOR LEGEND AND SEE SHEET 2 FOR CURVE TABLE

2 SHEET OF 6
CVL Contact: F. FLEET
CVL Project #: 14-0245826
CVL File #:

Printed By: Veenneta.J Print Date: May 5, 2016 File Name: N:\01024580\1\CADD\WEST\Residential\NHR1\DS\NHR1\FPLAT.03.dwg

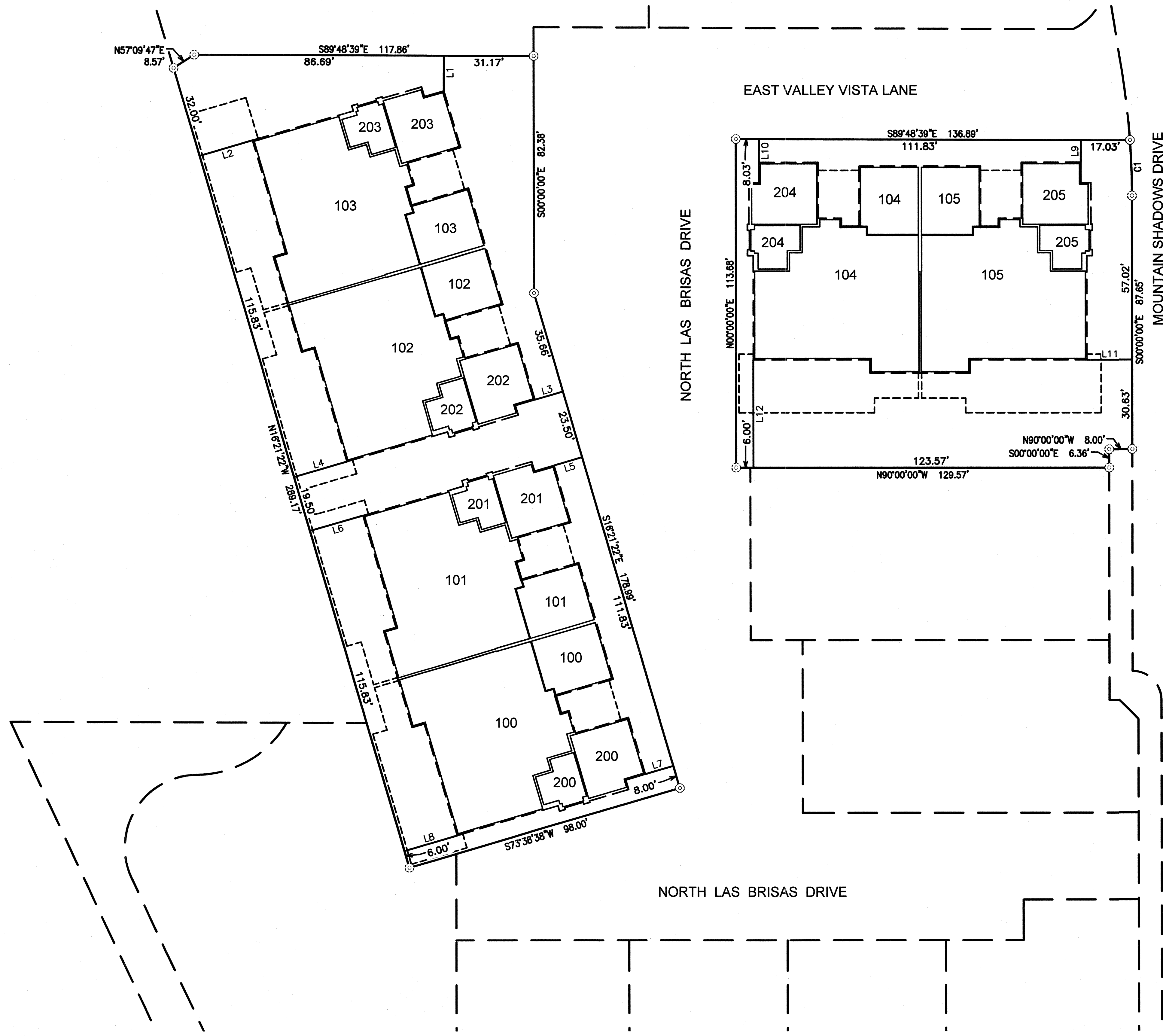

| CURVE TABLE | | | | | | |
|-------------|-------|--------|-----------|---------|-------|---------------|
| NO. | ARC | RADIUS | DELTA | TANGENT | CHORD | CHORD-BEARING |
| C1 | 19.23 | 273.82 | 00°01'28" | 9.62 | 19.23 | N02°00'44"W |

| LINE TABLE | | |
|------------|--------|-------------|
| NO. | LENGTH | BEARING |
| L1 | 12.25 | N00°11'21"E |
| L2 | 19.17 | S73°38'38"W |
| L3 | 10.17 | N73°38'38"E |
| L4 | 19.17 | S73°38'38"W |
| L5 | 10.17 | N73°38'38"E |
| L6 | 19.17 | S73°38'38"W |
| L7 | 10.17 | N73°38'38"E |
| L8 | 19.17 | S73°38'38"W |
| L9 | 7.63 | N00°11'21"E |
| L10 | 8.00 | N00°11'21"E |
| L11 | 15.73 | N90°00'00"E |
| L12 | 36.99 | S00°00'00"E |

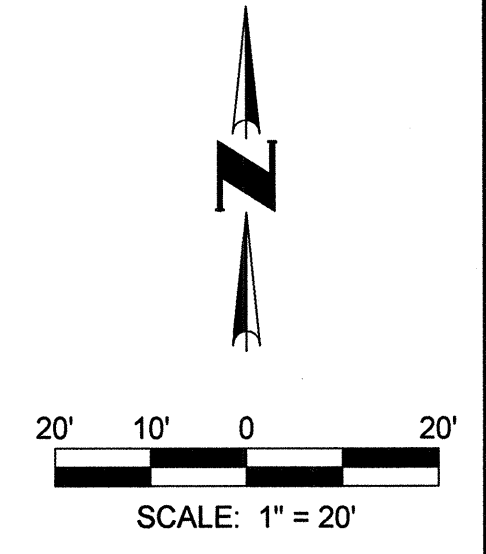

FIRST LEVEL PLAN SEE SHEET 1 FOR LEGEND AND SEE SHEET 2 FOR CURVE TABLE

COUNTY RECORDER

CVL CONSULTANTS
 4550 North 12th Street
 Phoenix, Arizona 85014
 602-264-6831
 www.cvlci.com

| NO. | REVISION | DATE |
|-----|----------|------|
| | | |
| | | |

FINAL PLAT
 THE VILLAS AT MOUNTAIN SHADOWS - AMENDED -
 CONDOMINIUM
 PARADISE VALLEY, ARIZONA

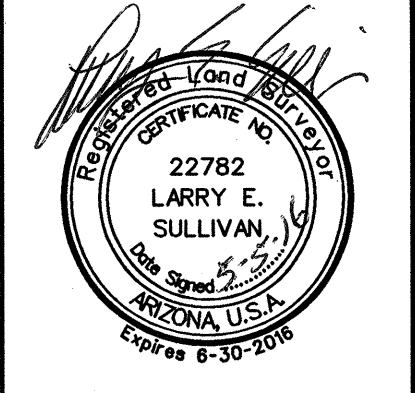

3 SHEET OF 6
 CVL Contact: F. FLEET
 CVL Project #: 14-0245826
 CVL File #:

Printed By: Venetia, J Print Date: May 5, 2016 Filename: N:\01024580\1\CADD\WEST\Residential\NHR\1DS\NH.R1\FPLAT.03.dwg

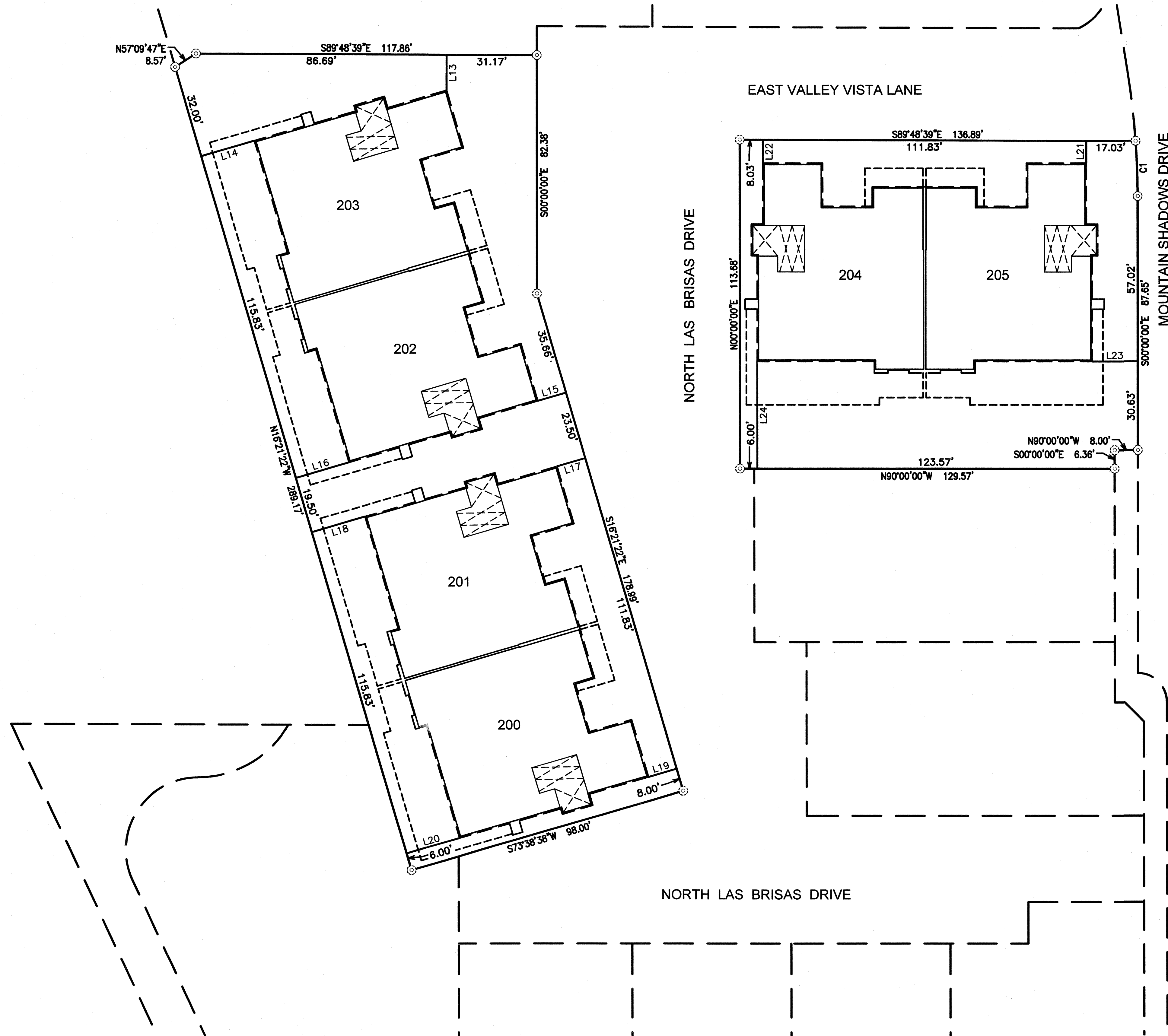

| CURVE TABLE | | | | | | |
|-------------|-------|--------|------------|---------|-------|---------------|
| NO. | ARC | RADIUS | DELTA | TANGENT | CHORD | CHORD-BEARING |
| C1 | 19.23 | 273.82 | 004°01'28" | 9.62 | 19.23 | N02°00'44"W |

| LINE TABLE | | |
|------------|--------|-------------|
| NO. | LENGTH | BEARING |
| L13 | 12.25 | N00°11'21"E |
| L14 | 19.17 | S73°38'38"W |
| L15 | 10.17 | N73°38'38"E |
| L16 | 19.17 | S73°38'38"W |
| L17 | 10.17 | N73°38'38"E |
| L18 | 19.17 | S73°38'38"W |
| L19 | 10.17 | N73°38'38"E |
| L20 | 19.17 | S73°38'38"W |
| L21 | 7.63 | N00°11'21"E |
| L22 | 8.00 | N00°11'21"E |
| L23 | 15.73 | N90°00'00"E |
| L24 | 36.99 | S00°00'00"E |

SECOND LEVEL PLAN

SEE SHEET 1 FOR LEGEND AND
SEE SHEET 2 FOR CURVE TABLE

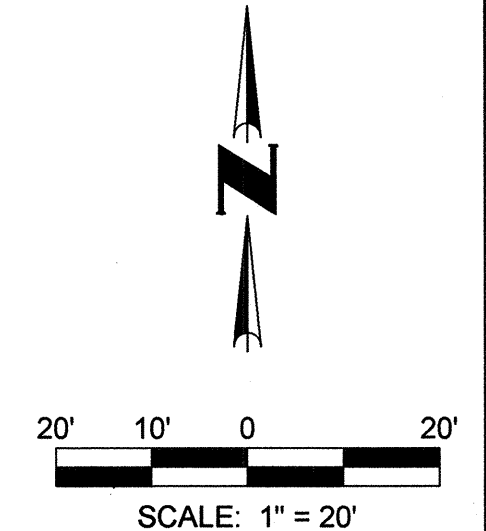

COUNTY RECORDER

| NO. | REVISION | DATE |
|-----|----------|------|
| | | |
| | | |
| | | |

FINAL PLAT

THE VILLAS AT MOUNTAIN SHADOWS - AMENDED -
CONDOMINIUM
PARADISE VALLEY, ARIZONA

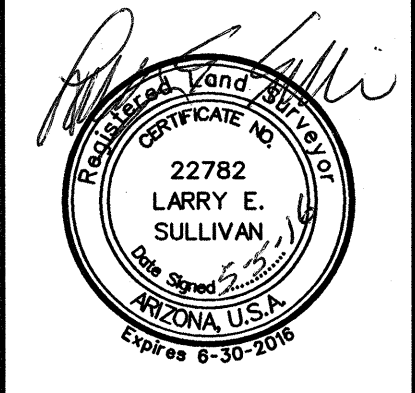

4 SHEET OF 6
CVL Contact: F. FLEET
CVL Project #: 14-0245826
CVL File #:

CVL CONSULTANTS
4550 North 12th Street
Phoenix, Arizona 85014
602-264-6831
www.cvlci.com

Coe and Van Loo II L.L.C.

DATE

REVISION

NO.

Coe and Van Loo II L.L.C.

FINAL PLAT

THE VILLAS AT MOUNTAIN SHADOWS - AMENDED -
CONDOMINIUM
PARADISE VALLEY, ARIZONA

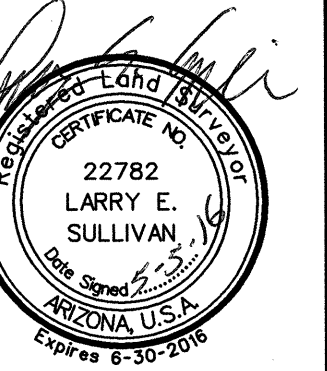

5 SHEET OF 6

CVL Contact: F. FLEET
CVL Project #: 14-0245826
CVL File #:

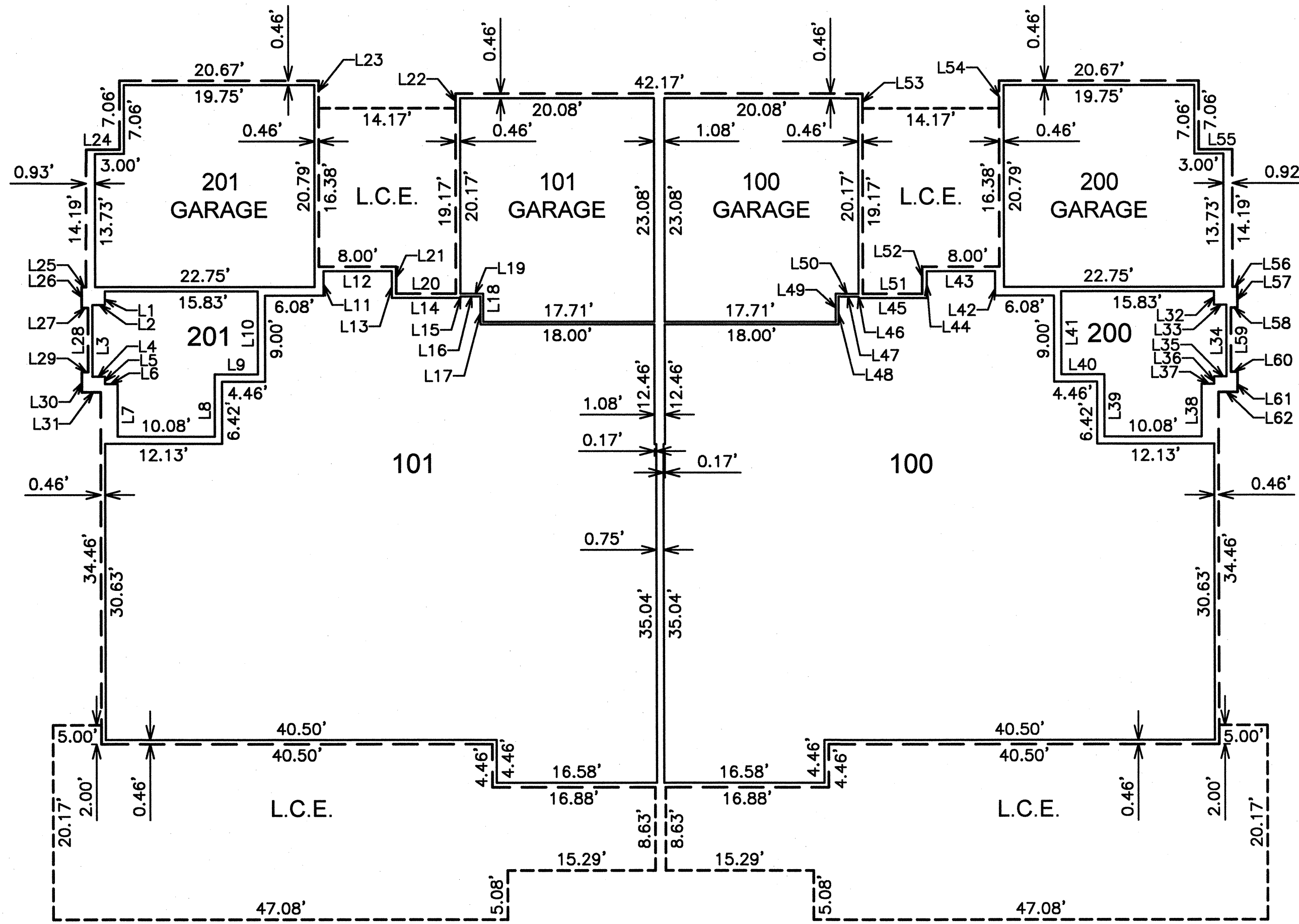

TYPE A FIRST LEVEL

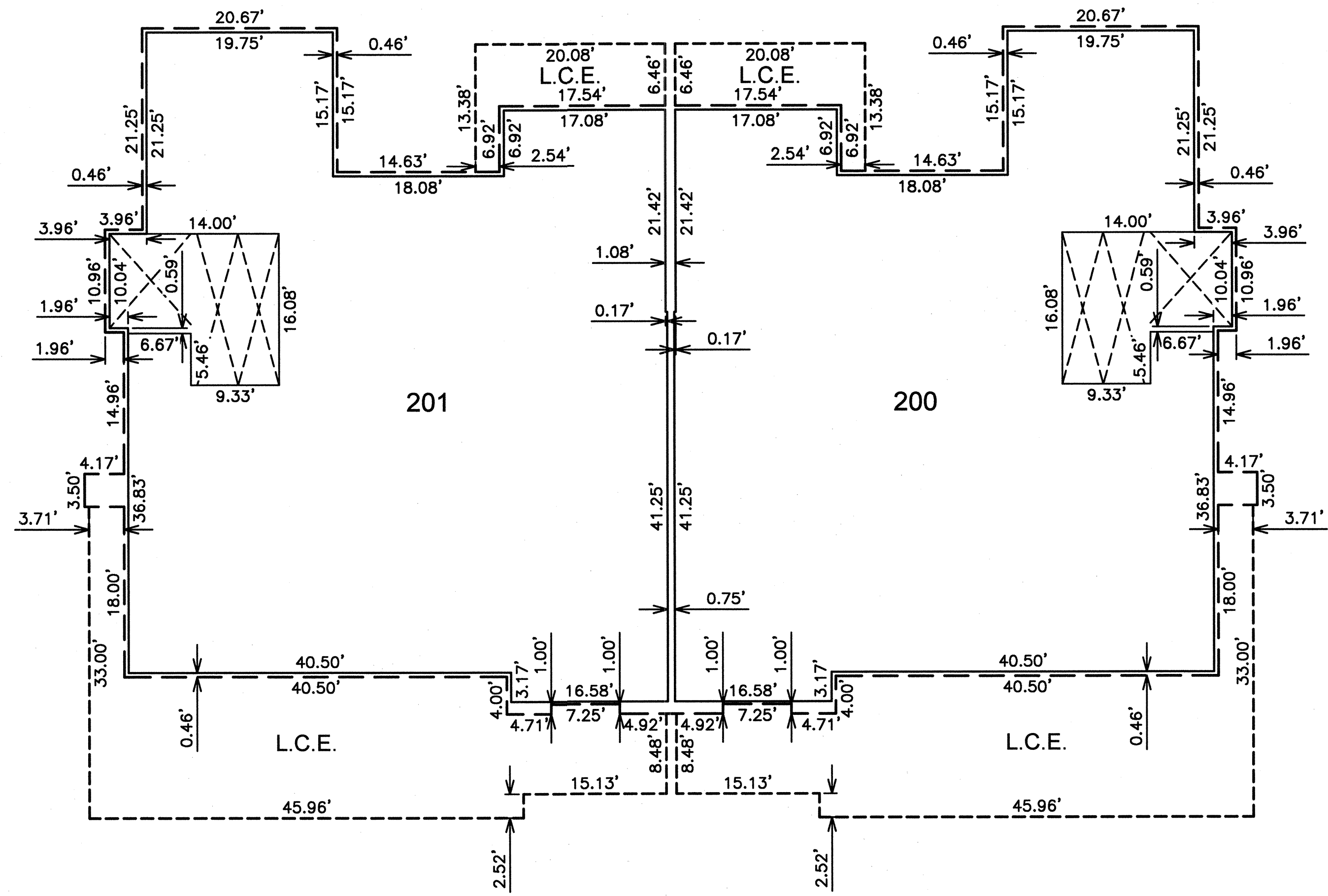

TYPE A SECOND LEVEL

| NO. | LENGTH |
|-----|--------|
| L1 | 1.42 |
| L2 | 1.29 |
| L3 | 7.50 |
| L4 | 1.29 |
| L5 | 0.75 |
| L6 | 1.29 |
| L7 | 5.46 |
| L8 | 6.42 |
| L9 | 4.46 |
| L10 | 8.71 |
| L11 | 2.54 |
| L12 | 7.08 |
| L13 | 2.79 |
| L14 | 7.08 |
| L15 | 0.17 |
| L16 | 2.08 |

| NO. | LENGTH |
|-----|--------|
| L17 | 2.92 |
| L18 | 2.92 |
| L19 | 2.38 |
| L20 | 6.17 |
| L21 | 2.79 |
| L22 | 1.46 |
| L23 | 2.79 |
| L24 | 3.46 |
| L25 | 0.46 |
| L26 | 2.19 |
| L27 | 0.67 |
| L28 | 6.71 |
| L29 | 0.67 |
| L30 | 2.06 |
| L31 | 1.96 |
| L32 | 1.42 |

| NO. | LENGTH |
|-----|--------|
| L33 | 1.29 |
| L34 | 7.50 |
| L35 | 1.29 |
| L36 | 0.75 |
| L37 | 1.29 |
| L38 | 5.46 |
| L39 | 6.42 |
| L40 | 4.46 |
| L41 | 8.71 |
| L42 | 2.54 |
| L43 | 7.08 |
| L44 | 2.79 |
| L45 | 7.08 |
| L46 | 0.17 |
| L47 | 2.08 |
| L48 | 2.92 |

| NO. | LENGTH |
|-----|--------|
| L49 | 2.92 |
| L50 | 2.38 |
| L51 | 6.17 |
| L52 | 2.79 |
| L53 | 1.46 |
| L54 | 2.79 |
| L55 | 3.46 |
| L56 | 0.50 |
| L57 | 2.19 |
| L58 | 0.67 |
| L59 | 6.71 |
| L60 | 0.67 |
| L61 | 2.06 |
| L62 | 1.96 |

| UNIT | SQUARE FEET | | L.B.E. | U.B.E. |
|------|-------------|--------|---------|---------|
| | TOTAL | GARAGE | | |
| 100 | 2435 | 457 | 1373.00 | 1383.08 |
| 101 | 2435 | 457 | 1373.00 | 1383.08 |
| 104 | 2435 | 457 | 1372.00 | 1382.08 |
| 105 | 2435 | 457 | 1372.00 | 1382.08 |

| UNIT | SQUARE FEET | | | | L.B.E. | U.B.E. |
|------|-------------|-----------|-------|--------|---------|---------|
| | 1ST FLOOR | 2ND FLOOR | TOTAL | GARAGE | | |
| 200 | 214 | 3237 | 3451 | 452 | 1384.46 | 1394.54 |
| 201 | 214 | 3237 | 3451 | 452 | 1384.46 | 1394.54 |
| 204 | 214 | 3237 | 3451 | 452 | 1383.46 | 1393.54 |
| 205 | 214 | 3237 | 3451 | 452 | 1383.46 | 1393.54 |

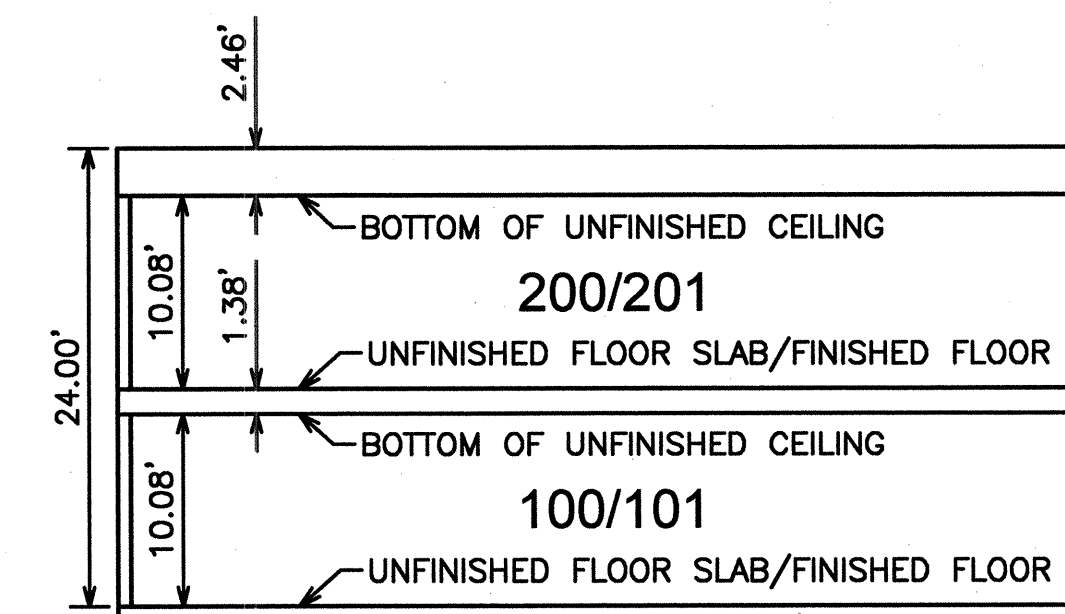

TYPE A VERTICAL SCHEMATIC

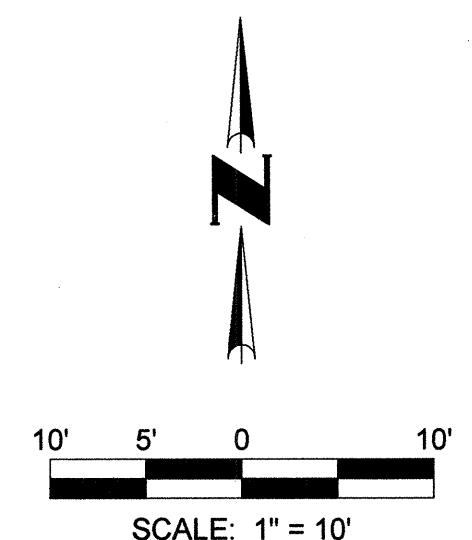

**TYPE A
UNIT PLANS**

SEE SHEET 1 FOR LEGEND AND
SEE SHEET 2 FOR CURVE TABLE

COUNTY RECORDER

DATE
 REVISION
 NO.

Coe and Van Loo II L.L.C.

FINAL PLAT
 THE VILLAS AT MOUNTAIN SHADOWS - AMENDED -
 CONDOMINIUM
 PARADISE VALLEY, ARIZONA

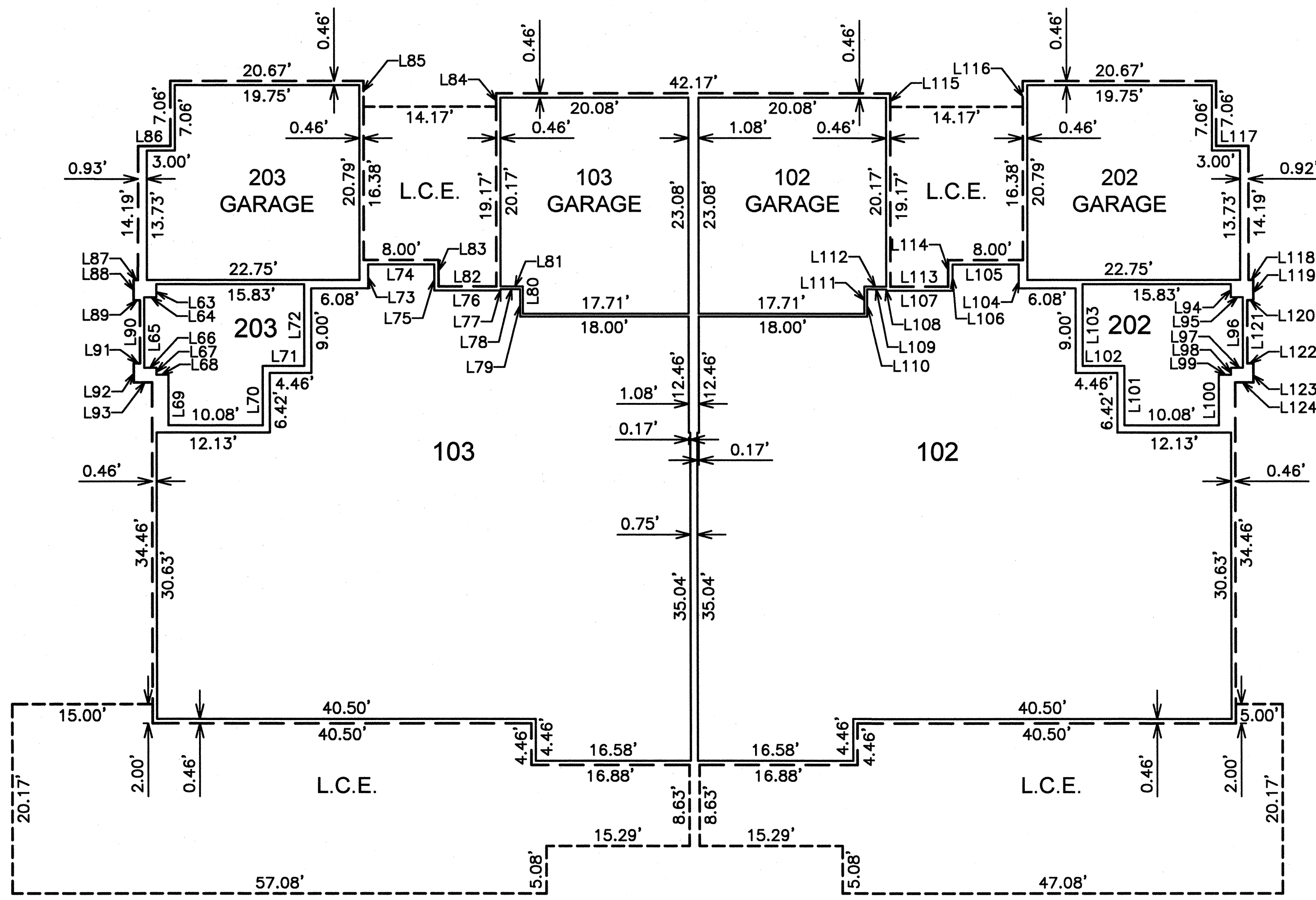
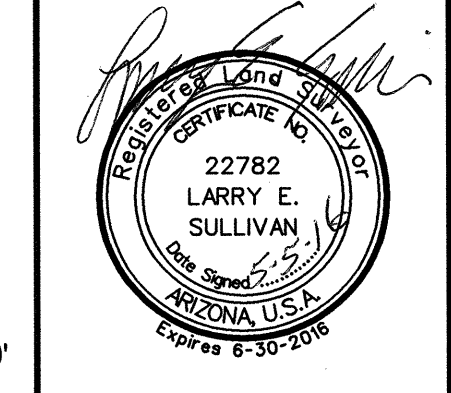

TYPE B FIRST LEVEL

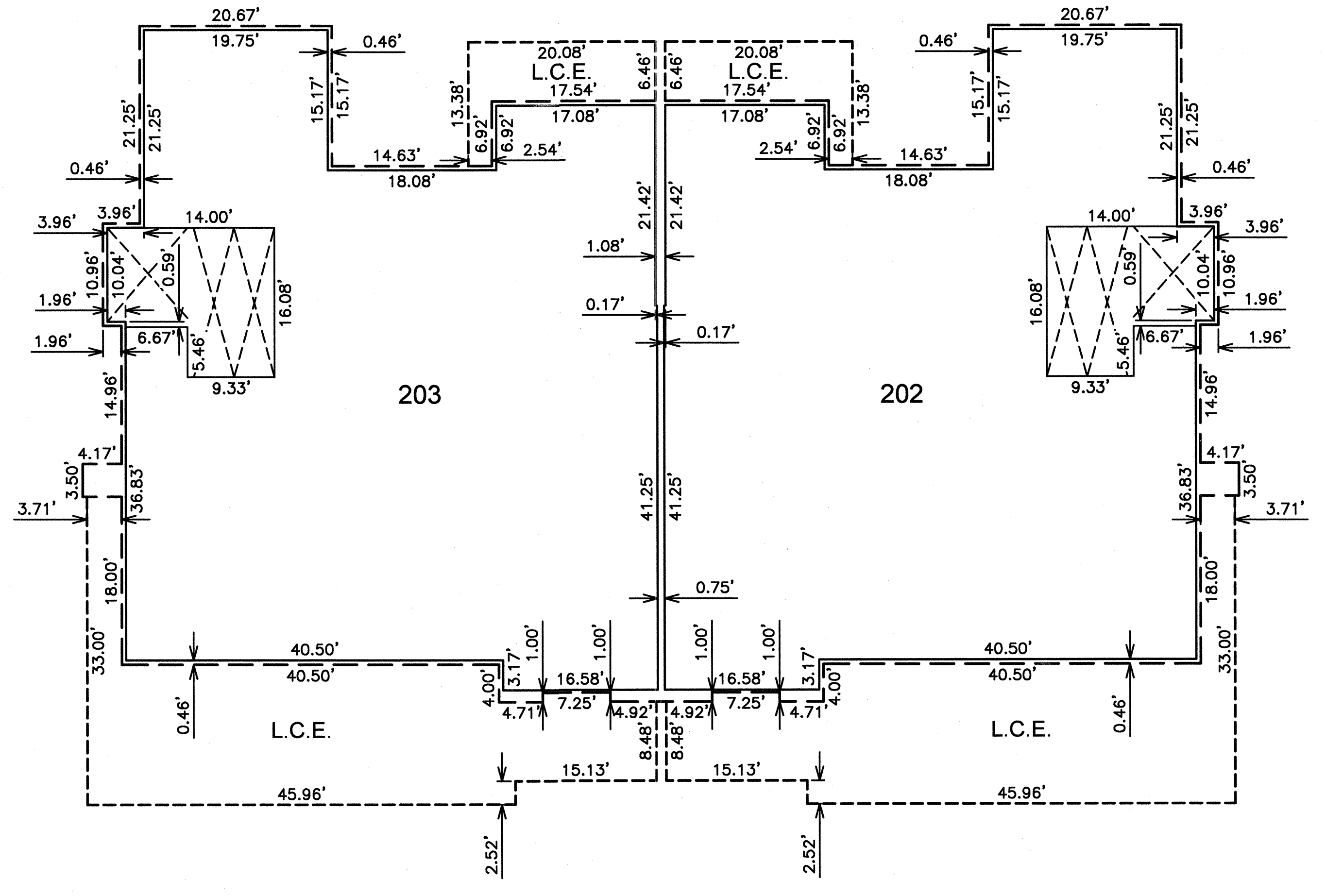

TYPE B SECOND LEVEL

| NO. | LENGTH |
|-----|--------|
| L63 | 1.42 |
| L64 | 1.29 |
| L65 | 7.50 |
| L66 | 1.29 |
| L67 | 0.75 |
| L68 | 1.29 |
| L69 | 5.46 |
| L70 | 6.42 |
| L71 | 4.46 |
| L72 | 8.71 |
| L73 | 2.54 |
| L74 | 7.08 |
| L75 | 2.79 |
| L76 | 7.08 |
| L77 | 0.17 |
| L78 | 2.08 |

| NO. | LENGTH |
|-----|--------|
| L79 | 2.92 |
| L80 | 2.92 |
| L81 | 2.38 |
| L82 | 6.17 |
| L83 | 2.79 |
| L84 | 1.46 |
| L85 | 2.79 |
| L86 | 3.46 |
| L87 | 0.46 |
| L88 | 2.19 |
| L89 | 0.67 |
| L90 | 6.71 |
| L91 | 0.67 |
| L92 | 2.06 |
| L93 | 1.96 |
| L94 | 1.42 |

| NO. | LENGTH |
|------|--------|
| L95 | 1.29 |
| L96 | 7.50 |
| L97 | 1.29 |
| L98 | 0.75 |
| L99 | 1.29 |
| L100 | 5.46 |
| L101 | 6.42 |
| L102 | 4.46 |
| L103 | 8.71 |
| L104 | 2.54 |
| L105 | 7.08 |
| L106 | 2.79 |
| L107 | 7.08 |
| L108 | 0.17 |
| L109 | 2.08 |
| L110 | 2.92 |

| NO. | LENGTH |
|------|--------|
| L111 | 2.92 |
| L112 | 2.38 |
| L113 | 6.17 |
| L114 | 2.79 |
| L115 | 1.46 |
| L116 | 2.79 |
| L117 | 3.46 |
| L118 | 0.50 |
| L119 | 2.19 |
| L120 | 0.67 |
| L121 | 6.71 |
| L122 | 0.67 |
| L123 | 2.06 |
| L124 | 1.96 |

| UNIT | SQUARE FEET | | L.B.E. | U.B.E. |
|------|-------------|--------|---------|---------|
| | TOTAL | GARAGE | | |
| 102 | 2435 | 457 | 1371.00 | 1381.08 |
| 103 | 2435 | 457 | 1371.00 | 1381.08 |

| UNIT | SQUARE FEET | | | | L.B.E. | U.B.E. |
|------|-------------|-----------|-------|--------|---------|---------|
| | 1ST FLOOR | 2ND FLOOR | TOTAL | GARAGE | | |
| 202 | 214 | 3237 | 3451 | 452 | 1382.46 | 1392.54 |
| 203 | 214 | 3237 | 3451 | 452 | 1382.46 | 1392.54 |

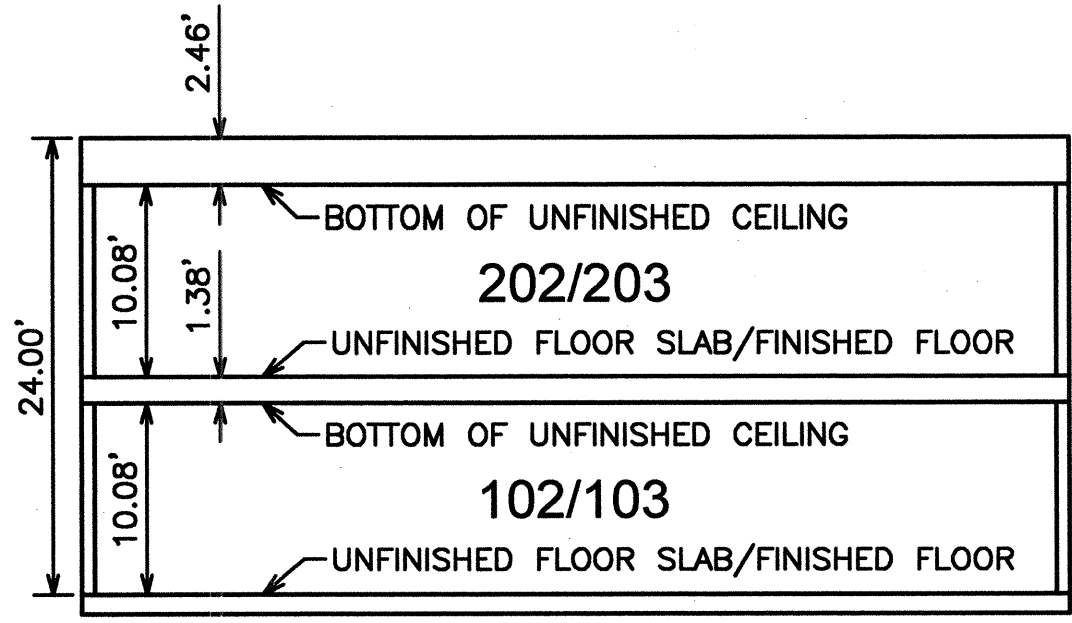

TYPE B VERTICAL SCHEMATIC

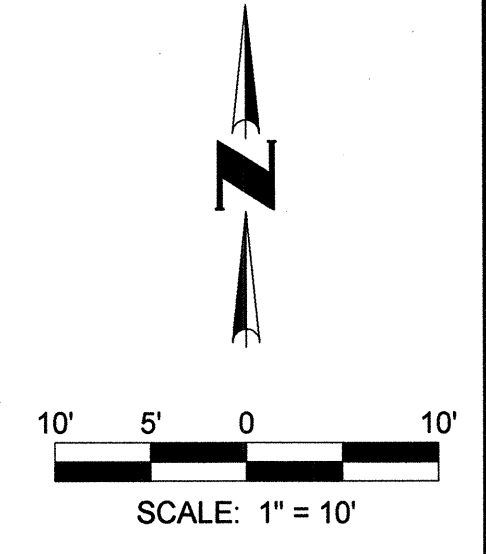

TYPE B UNIT PLANS
 SEE SHEET 1 FOR LEGEND AND
 SEE SHEET 2 FOR CURVE TABLE