

FINAL PLAT FOR THE VILLAS AT MOUNTAIN SHADOWS II - CONDOMINIUMS

A CONDOMINIUM PLAT UPON TRACT E OF "THE VILLAS AT MOUNTAIN SHADOWS II" AS RECORDED IN BOOK 1251 OF MAPS, PAGE 16, M.C.R., AND SITUATED IN THE SOUTHEAST QUARTER OF SECTION 8, TOWNSHIP 2 NORTH, RANGE 4 EAST OF THE GILA AND SALT RIVER BASE AND MERIDIAN MARICOPA COUNTY, ARIZONA

NOTES

- THE BOUNDARIES OF EACH UNIT ARE AS FOLLOWS PER THE CONVEYANCE, CONDITIONS & RESTRICTIONS (C&R):
 - THE VERTICAL BOUNDARIES ARE THE INTERIOR FINISHED SURFACES OF THE PERIMETER WALLS OF THE UNIT.
 - THE CEILING HORIZONTAL BOUNDARY IS THE TOP SURFACE OF THE FLOOR SLAB BENEATH THE UNIT, AND
 - THE UPPER AND LOWER HORIZONTAL BOUNDARIES OF EACH UNIT SHALL BE FROM THE UNFINISHED FLOOR OR EACH UNIT TO THE UNFINISHED CEILING OF EACH UNIT.
 - COLUMNS AND SHIFTS ARE EXEMPT FROM BUILDING, UNITS, STORAGE AND PARKING DIMENSIONS.
- COMMON ELEMENTS (C.E.) AND LIMITED COMMON ELEMENTS (L.C.E.) ARE MORE FULLY DESCRIBED IN THE DECLARATION OF CONDOMINIUMS TO BE RECORDED FOLLOWING THE RECORDING OF THIS PLAT. LAND DIMENSIONS TO BE RECORDED ARE SHOWN AS FOLLOWS:
 - THE SHOWN ARE TO OUTSIDE FACE OF BUILDINGS (GROUND LEVEL).
 - NO POWER POLES EXIST ON-SITE.
 - BUILDING HEIGHT WILL COMPLY WITH THE MOUNTAIN SHADOWS RESORT "SPECIAL USE PERMIT - RESORT" REQUIREMENTS.

OWNER

THE MOUNTAIN SHADOWS, L.L.C. A DELAWARE LIMITED LIABILITY COMPANY
 4550 NORTH 12TH STREET
 SCOTTSDALE, AZ 85233
 PHONE: (480) 634-6487
 CONTACT: JOHN F. HODGNEY, PRESIDENT

ARCHITECT

DAK PARTNERS
 3240 BRISTOL STREET, SUITE 650
 COSTA MESA, CALIFORNIA 92626
 PHONE: (714) 440-1100
 CONTACT: BRYAN STAHLER

ENGINEER

COE & VAN LOO CONSULTANTS, INC.
 4550 NORTH 12TH STREET
 SCOTTSDALE, AZ 85233
 PHONE: (602) 244-4881
 FAX: (602) 244-9928
 CONTACT: FRED L. FLEET, P.E., F.A.S.C.E.

UTILITY PROVIDERS

- | | |
|-----------|------------------------|
| SEWER | CITY OF PHOENIX |
| WATER | EPOR WATER |
| TELEPHONE | CENTURYLINK |
| CABLE | COX COMMUNICATIONS |
| GAS | SOUTHWEST GAS |
| ELECTRIC | ARIZONA PUBLIC SERVICE |

LEGEND

- INDICATES SECTION CORNER - FOUND BRASS CAP (UNLESS OTHERWISE NOTED)
- INDICATES EXTERIOR BOUNDARY (UNLESS OTHERWISE NOTED)
- INDICATES INTERIOR BOUNDARY
- INDICATES EXTERIOR FACE
- INDICATES FLOOR LIMITS
- INDICATES OPEN TO FLOOR BELOW
- INDICATES LIMITS OF TERRACE
- INDICATES SHEET NUMBER
- INDICATES 50' x 50' SIGHT VISIBILITY TRIANGLE
- INDICATES UTILITY EASEMENT PER BOOK 1232 OF MAPS, PAGE 27, M.C.R.
- INDICATES CURVE NUMBER
- INDICATES EASEMENT CURVE NUMBER
- INDICATES SQUARE FEET
- INDICATES COMMON ELEMENT
- INDICATES LIMITED COMMON ELEMENT
- INDICATES DESIGNATED PARKING SPACE NUMBER
- INDICATES DESIGNATED STORAGE ROOM NUMBER
- INDICATES LOWER BOUNDARY ELEVATION
- INDICATES UPPER BOUNDARY ELEVATION

DRAINAGE EASEMENT RESTRICTIONS

PURSUANT TO A.R.S. §48-101(C), AND SECTION 64 (E), 20-1 ET. SEQ. AND 63-34 OF ARIZONA REVISED STATUTES, THE FOLLOWING RESTRICTIONS APPLY TO THE EASEMENTS ARE FOR THE PURPOSE OF ALLOWING STORAGE FLOOD AND OTHER WATERS TO PASS OVER, UNDER, OR THROUGH THE LAND SET ASIDE FOR SUCH PURPOSES. THE EASEMENTS ARE TO BE CONSTRUCTED, PLACED, PLANTED OR ALLOWED TO GROW ON OR IN SUCH EASEMENTS, THE MAINTENANCE AND CLEARING OF THESE EASEMENTS SHALL BE THE RESPONSIBILITY OF THE PERSON OR ENTITY WHOSE INTEREST OF THE PROPERTY ON WHICH SAID EASEMENTS ARE PLACED. HOWEVER, IF THE TOWN OR DEVELOPER OF THE PROPERTY HAS A DRAINAGE FACILITY ON OR UNDER SUCH EASEMENTS, THE TOWN OR DEVELOPER OF THE PROPERTY SHALL HAVE FREE ACCESS TO AND FROM ALL PORTIONS OF SUCH EASEMENTS AT ALL TIMES.

100 YEAR ASSURED WATER SUPPLY

THE AREA PLATTED HEREON LIES WITHIN THE DOMESTIC WATER SERVICE AREA OF EPORA WATER ARIZONA INC. - PARADISE VALLEY WHICH IS DESIGNATED AS HAVING AN ASSURED WATER SUPPLY PURSUANT TO SECTION 45-576 ARIZONA REVISED STATUTES AND IS SUBJECT TO THE PROVISIONS OF THE ASSURED WATER SUPPLY ACT (ARIZONA REVISED STATUTES 29-70203-2001 DATED MARCH 18, 2016).

BASIS OF BEARING

THE BASIS OF BEARING FOR THIS SURVEY IS NORTH 00°12'52" WEST ALONG THE EAST LINE OF THE SOUTHEAST QUARTER OF SECTION 8, TOWNSHIP 2 NORTH, RANGE 4 EAST OF THE GILA AND SALT RIVER MERIDIAN, MARICOPA COUNTY, ARIZONA.

BENCHMARK

EAST 1/4 CORNER OF SECTION 8, TOWNSHIP 2 NORTH, RANGE 4 EAST TOWN OF PARADISE VALLEY BRASS CAP IN HANDHOLE LOCATED AT THE INTERSECTION OF 50TH STREET & LINCOLN BOULEVARD (MCDONALD'S) (MCDONALD'S TRACT NO. 24524-1 N. 20751.84, E. 86442.88)

SITE DATA

EXISTING ZONING SLUP - RESORT
 TOTAL UNITS 40

DEDICATION

STATE OF ARIZONA)
 COUNTY OF MARICOPA) SS
 KNOW ALL MEN BY THESE PRESENTS:
 THAT THE MOUNTAIN SHADOWS, L.L.C. A DELAWARE LIMITED LIABILITY COMPANY, AS OWNER, HAS SUBMITTED UNDER THE NAME OF THE VILLAS AT MOUNTAIN SHADOWS II - CONDOMINIUMS A CONDOMINIUM PLAT UPON TRACT E OF "THE VILLAS AT MOUNTAIN SHADOWS II" AS RECORDED IN BOOK 1251 OF MAPS, PAGE 16, M.C.R., AND SITUATED IN THE SOUTHEAST QUARTER OF SECTION 8, TOWNSHIP 2 NORTH, RANGE 4 EAST OF THE GILA AND SALT RIVER BASE AND MERIDIAN, MARICOPA COUNTY, ARIZONA, AS SHOWN ON THE ATTACHED PLAT SETS FORTH THE LOCATION AND GIVES THE DIMENSIONS OF THE BOUNDARIES OF THE CONDOMINIUM UNITS, AND THAT EACH UNIT SHALL BE KNOWN BY THE NUMBER OR LETTER SHOWN EACH RESPECTIVELY ON SAID PLAT.

IN WITNESS WHEREOF:

THE MOUNTAIN SHADOWS, L.L.C. A DELAWARE LIMITED LIABILITY COMPANY, AS OWNER OF SAID PLAT AND DESCRIBED THEREIN HAS CAUSED THE UNDERSIGNED DULY AUTHORIZED OFFICER

THE MOUNTAIN SHADOWS, L.L.C. A DELAWARE LIMITED LIABILITY COMPANY
 BY: JOHN F. HODGNEY, PRESIDENT
 ITS AUTHORIZED SIGNATORY DATE: _____

ACKNOWLEDGEMENT

STATE OF ARIZONA)
 COUNTY OF MARICOPA) SS
 ON THIS _____ DAY OF _____, 2016, BEFORE ME, THE UNDERSIGNED NOTARY PUBLIC IN AND FOR SAID STATE, PERSONALLY APPEARED _____ PERSONALLY KNOWN TO ME OR PROOVED TO ME ON THE BASIS OF SATISFACTORY EVIDENCE TO BE THE PERSON WHOSE NAME IS SUBSCRIBED TO THE WITHIN INSTRUMENT AND ACKNOWLEDGED TO ME THAT HE/SHE IS THE SIGNATORY OF SAID INSTRUMENT AND THAT HE/SHE HAS EXECUTED SAID INSTRUMENT SIGNATURE ON THE INSTRUMENT THE PERSON, OR THE ENTITY UPON BEHALF OF WHICH THE PERSON ACTED, EXECUTED THE INSTRUMENT.
 WITNESS MY HAND AND OFFICIAL SEAL

NOTARY PUBLIC

APPROVED BY THE TOWN COUNCIL OF THE TOWN OF PARADISE VALLEY, ARIZONA THIS _____ DAY OF _____, 2016.
 BY: MAYOR _____
 ATTEST: TOWN CLERK _____
 TOWN ENGINEER _____
 PLANNING DIRECTOR _____

APPROVAL

APPROVED BY THE TOWN COUNCIL OF THE TOWN OF PARADISE VALLEY, ARIZONA THIS _____ DAY OF _____, 2016.

SHEET INDEX

- COVER SHEET, DEDICATION, NOTES
- BOUNDARY MAP
- SECOND LEVEL PLAN
- UNIT PLANS / VERTICAL SCHEMATICS 5-11

COUNTY RECORDER

CYL CONSULTANT
 4550 NORTH 12TH STREET
 PHOENIX, ARIZONA 85014
 WWW.CVLD.COM
 602-284-6891

NO.	REVISION	DATE

THE VILLAS AT MOUNTAIN SHADOWS II - CONDOMINIUMS
 PARADISE VALLEY, ARIZONA
 FINAL PLAT



1 SHEET OF 11
 SEE SHEET 1 FOR LEGEND AND CALCULATIONS
 SEE SHEET 2 FOR CURVE TABLE

GROSS AREA = 5.166 ACRES

FINAL PLAN

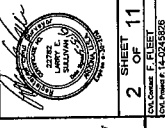

COUNTY RECORDER

LINE TABLE		
NO.	LENGTH	BEARING
L1	4.59	S29°55'00"E
L2	1.83	N89°00'00"E
L3	15.75	S80°00'00"E
L4	6.00	N87°52'48"W
L5	12.00	N87°17'17"W
L6	6.00	S85°42'24"E
L7	5.12	S20°00'00"E
L8	12.00	N87°52'12"W
L9	5.96	N87°29'44"E
L10	6.00	N89°00'00"E
L11	12.00	S00°00'00"E
L12	12.00	S00°00'00"E
L13	12.27	N87°00'00"E

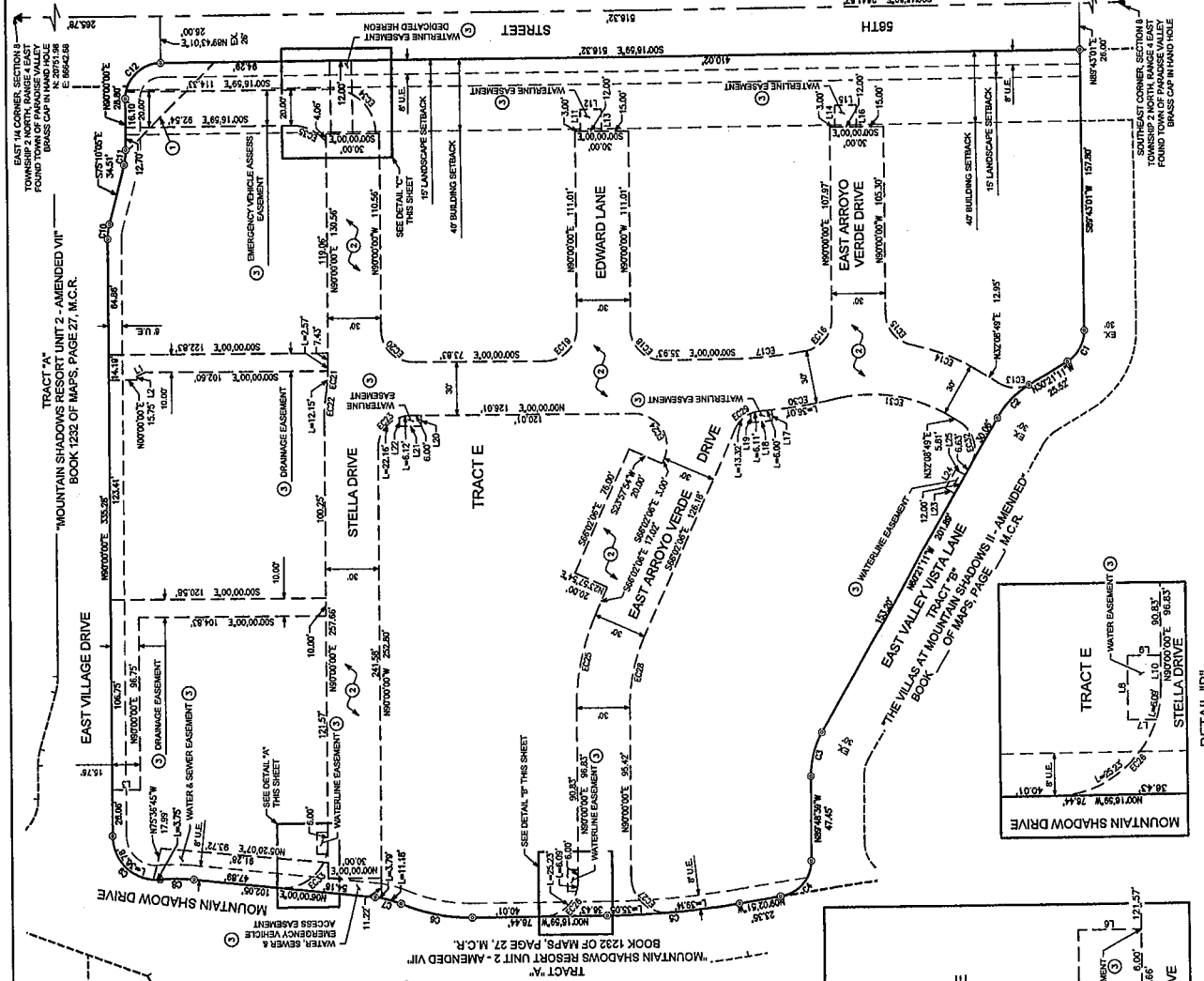
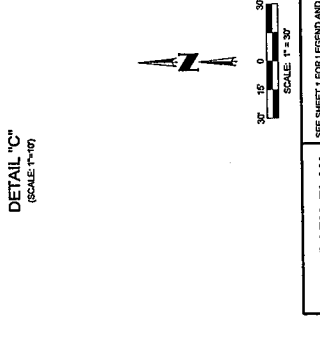
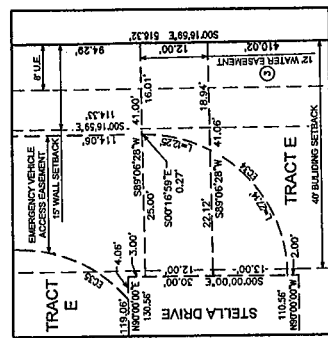
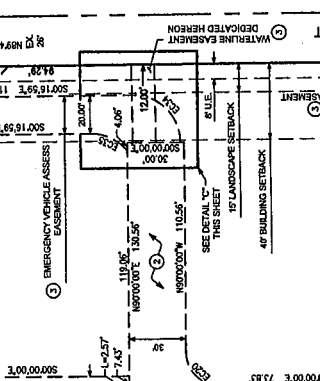

CURVE TABLE

NO.	ARC	RADIUS	DELTA	TANGENT	CHORD	CHORD-BEARING
C1	20.92	21.00	0°57'54"	11.53	19.28	S97°19'05"E
C2	26.18	50.00	0°57'00"	13.40	23.42	N87°21'11"W
C3	25.71	50.00	0°57'27"	13.14	23.42	N87°34'55"W
C4	28.19	20.00	0°49'45"	17.01	25.92	S49°25'45"E
C5	74.19	485.00	0°45'32"	37.17	74.12	S49°39'55"E
C6	40.91	100.00	0°57'26"	20.75	40.63	S17°26'14"W
C7	14.97	50.00	0°17'27"	7.54	14.92	N4°24'44"E
C8	18.63	100.00	0°47'15"	9.44	18.60	N07°39'23"E
C9	40.53	24.50	0°44'15"	26.64	36.07	S42°35'49"W
C10	8.41	32.50	0°14'49'35"	4.23	8.39	N82°35'02"W
C11	8.41	32.50	0°14'49'35"	4.23	8.39	S82°35'02"E
C12	31.32	20.00	0°49'30"	19.90	28.21	N45°00'29"W
C13	18.63	18.00	0°47'15"	11.53	18.68	N07°39'23"E
C14	41.18	115.00	0°23'10"	20.81	40.95	N17°53'17"E
C15	24.62	18.00	0°17'27"	14.67	22.75	S58°48'53"W
C16	24.65	18.00	0°17'27"	14.67	22.75	S58°48'53"E
C17	44.89	235.00	0°17'34"	22.41	44.62	S29°29'51"E
C18	28.27	18.00	0°49'30"	18.00	25.46	S47°00'00"E
C19	28.27	18.00	0°49'30"	18.00	25.46	S47°00'00"E
C20	28.27	18.00	0°49'30"	18.00	25.46	S47°00'00"E
C21	14.71	96.00	0°36'30"	7.37	14.70	S89°41'36"E
C22	15.31	102.00	0°36'30"	7.67	15.30	N89°41'36"E
C23	28.27	18.00	0°49'30"	18.00	25.46	N47°00'00"W
C24	35.90	18.00	1°13'57'54"	27.70	35.19	N78°58'57"E
C25	53.54	128.00	0°23'54"	27.17	53.15	N78°10'30"W
C26	31.32	20.00	0°49'30"	19.90	28.21	S47°00'00"E
C27	32.98	20.00	0°49'25"	21.91	29.35	S47°16'18"W
C28	40.98	50.00	0°37'54"	20.80	40.89	N78°10'30"W
C29	19.44	18.00	0°17'32"	10.79	18.51	N43°06'00"W
C30	42.01	265.00	0°07'56"	21.05	41.96	S08°42'27"E
C31	17.34	50.00	0°42'34"	15.55	16.60	N07°26'59"E
C32	27.49	18.00	0°37'00"	17.23	24.88	N75°34'48"E
C33	41.88	25.00	0°49'00"	27.77	37.18	S42°00'00"E
C34	30.38	25.00	0°41'59"	26.12	35.44	N44°51'31"E
C35	21.97	25.00	0°27'10"	11.75	21.27	N43°33'37"E

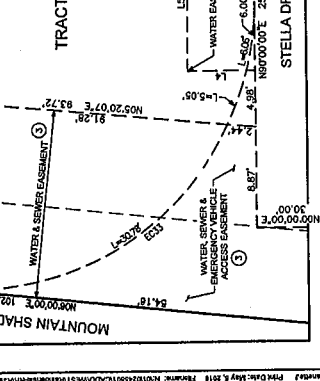
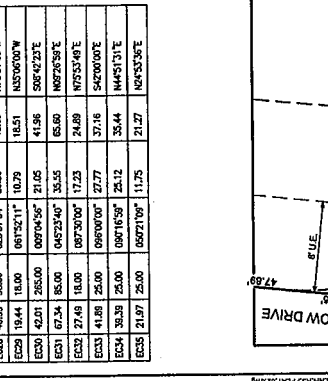
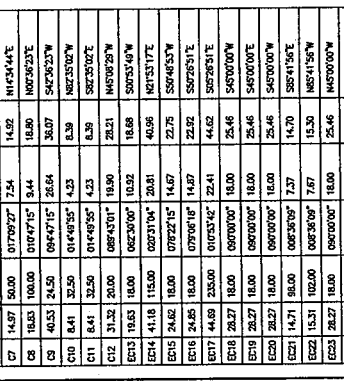

SEE SHEET FOR LEGEND AND
 SEE SHEET FOR CONTIGUOUS

BOUNDARY PLAN

SCALE: 1"=30'

SCALE: 1"=50'

SCALE: 1"=30'



COUNTY RECORDER

LINE NO.	LENGTH	BEARING
L1	35.92	N00°00'00"E
L2	35.92	N00°00'00"E
L3	35.92	N00°00'00"E
L4	35.92	N00°00'00"E
L5	38.17	N00°00'00"E
L6	41.98	N89°43'01"E
L7	44.08	N89°43'01"E
L8	42.40	N89°43'01"E
L9	44.42	N89°43'01"E
L10	42.46	N89°43'01"E
L11	43.96	N89°43'01"E
L12	42.30	S89°43'01"W
L13	52.02	S29°35'49"W
L14	18.63	S29°35'49"W
L15	15.79	S82°21'55"W
L16	25.40	S87°40'09"W
L17	18.68	S89°43'01"W
L18	13.83	N67°54'46"W
L19	19.70	N60°00'00"E
L20	23.70	N60°00'00"E
L21	53.81	S87°36'13"E
L22	57.81	S87°46'03"E



SCALE: 1"=30'

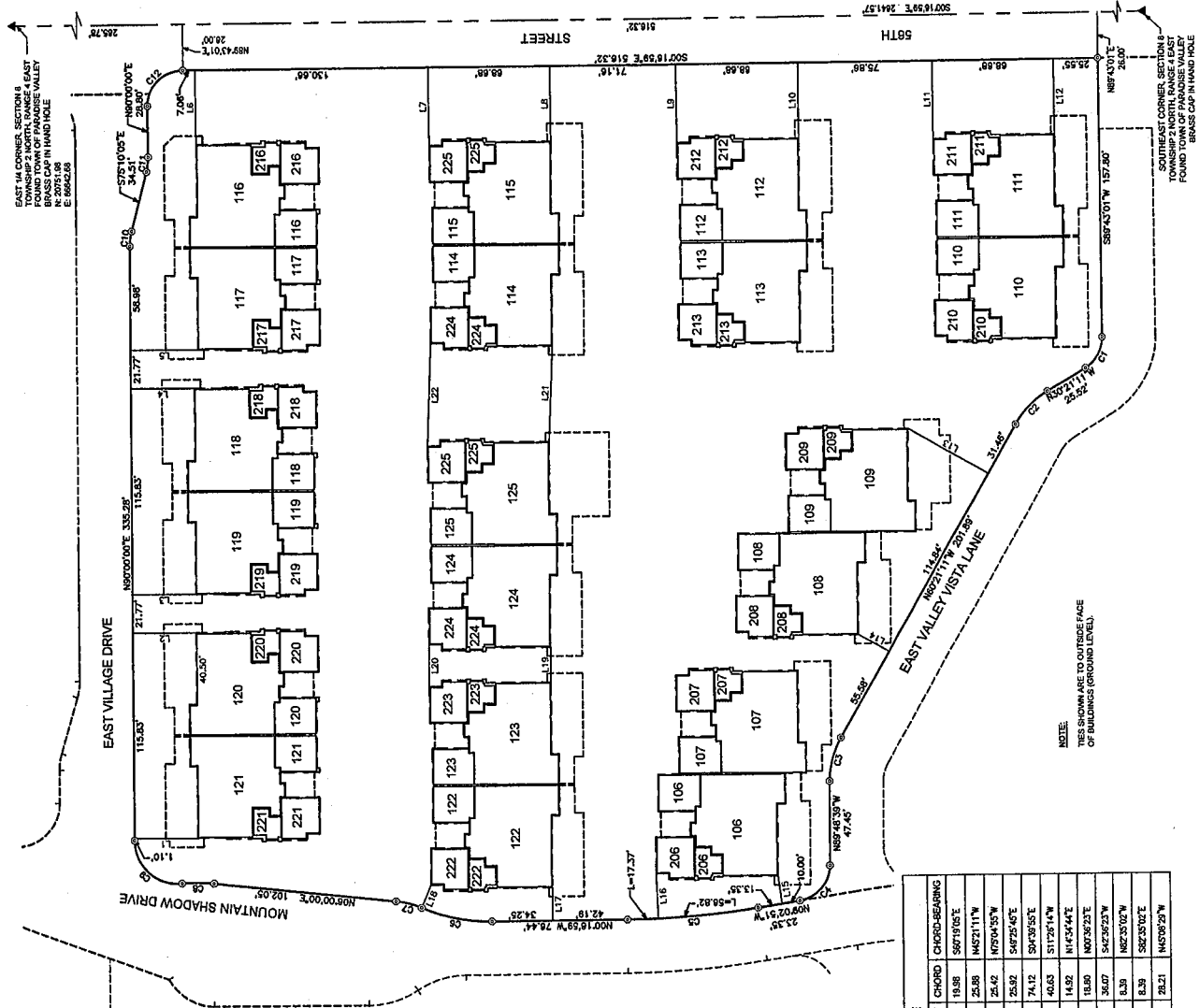

NO.	ARC	RADIUS	DELTA	TANGENT	CHORD	CHORD-BEARING
C1	26.32	20.00	109°54'46"	11.53	19.88	S87°19'10"E
C2	26.18	50.00	030°00'00"	13.40	25.88	N42°11'11"W
C3	25.71	50.00	029°27'28"	13.14	25.42	N75°04'35"W
C4	26.18	20.00	088°45'46"	12.01	25.92	S47°25'45"E
C5	74.19	465.00	008°45'52"	37.17	74.12	S94°39'35"E
C6	40.91	100.00	023°32'36"	20.75	40.63	S11°26'14"W
C7	14.97	50.00	017°09'27"	7.54	14.92	N1°43'44"E
C8	16.83	100.00	010°47'15"	8.44	16.60	N07°36'23"E
C9	40.33	24.50	084°47'15"	28.84	30.07	S42°29'23"W
C10	8.41	32.50	014°49'55"	4.23	8.39	S82°33'02"W
C11	8.41	32.50	014°49'55"	4.23	8.39	S82°33'02"E
C12	31.32	20.00	088°43'01"	19.90	28.21	N45°09'29"W



COUNTY RECORDER

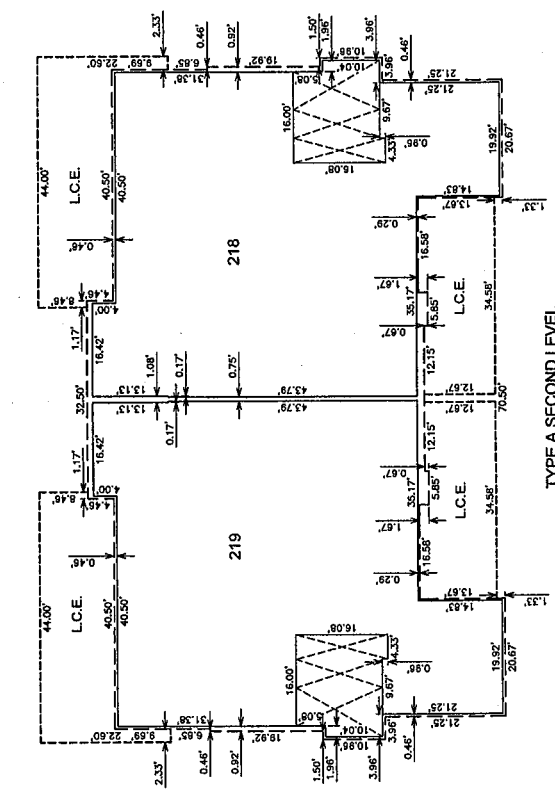

TYPE A SECOND LEVEL

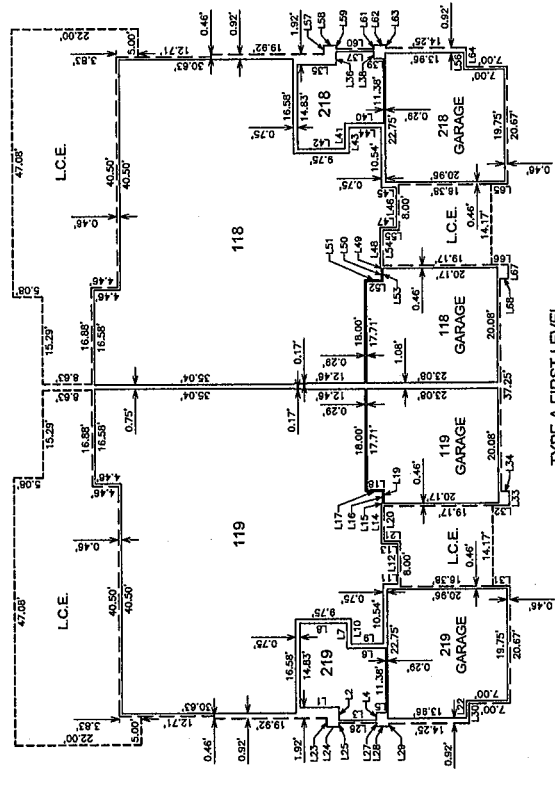

TYPE A FIRST LEVEL

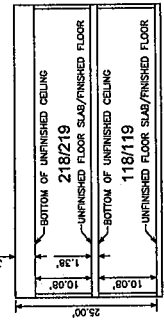

TYPE A VERTICAL SCHEMATIC

- LEGEND**
- INDICATES INTERIOR BOUNDARY
 - - - INDICATES EXTERIOR FACE
 - INDICATES FLOOR LIMITS
 - - - INDICATES OPEN TO FLOOR BELOW

SINGLE FLOOR UNIT DATA TABLE

UNIT	SQUARE FEET	L.B.E.	U.B.E.
118	2432	1365.65	1376.73
119	2432	1365.65	1376.73
218	2432	1365.00	1376.06
219	2432	1365.00	1376.06

TWO FLOOR UNIT DATA TABLE

UNIT	1ST FLOOR	2ND FLOOR	TOTAL	L.B.E.	U.B.E.
218	211	3122	3333	456	1376.11
219	211	3122	3333	456	1376.11
220	211	3122	3333	456	1377.46
221	211	3122	3333	456	1377.46

LINE TABLE		LINE TABLE		LINE TABLE		LINE TABLE	
NO.	LENGTH	NO.	LENGTH	NO.	LENGTH	NO.	LENGTH
L1	6.79	L16	2.82	L31	3.46	L46	7.08
L2	2.92	L17	4.46	L32	2.79	L47	2.79
L3	6.62	L18	8.25	L33	2.46	L48	7.08
L4	1.26	L19	5.67	L34	2.46	L49	0.17
L5	1.71	L20	1.50	L35	2.08	L50	2.08
L6	6.98	L21	3.00	L36	1.33	L51	2.92
L7	4.46	L22	1.50	L37	1.33	L52	2.92
L8	8.25	L23	1.50	L38	1.71	L53	0.46
L9	5.67	L24	2.17	L39	2.17	L54	3.46
L10	4.46	L25	0.67	L40	6.98	L55	2.79
L11	2.54	L26	6.62	L41	4.46	L56	2.79
L12	7.08	L27	0.67	L42	8.25	L57	2.46
L13	2.79	L28	2.17	L43	4.46	L58	1.33
L14	7.08	L29	0.50	L44	5.67	L59	0.67
L15	0.17	L30	3.46	L45	2.54	L60	6.62
L16	2.08	L31	3.46	L46	7.08	L61	0.67
L17	2.92	L32	2.79	L47	2.79	L62	2.17
L18	0.17	L33	2.79	L48	7.08	L63	0.46
L19	5.67	L34	2.46	L49	0.17	L64	3.46
L20	1.50	L35	2.46	L50	2.08	L65	2.79
L21	3.00	L36	1.33	L51	2.92	L66	2.79
L22	1.50	L37	1.33	L52	2.92	L67	2.46
L23	1.50	L38	1.71	L53	0.46	L68	1.33
L24	2.17	L39	2.17	L54	3.46	L69	0.46
L25	0.67	L40	6.98	L55	2.79	L70	0.46
L26	6.62	L41	4.46	L56	2.79	L71	0.46
L27	0.67	L42	8.25	L57	2.46	L72	0.46
L28	2.17	L43	4.46	L58	1.33	L73	0.46
L29	0.50	L44	5.67	L59	0.67	L74	0.46
L30	3.46	L45	2.54	L60	6.62	L75	0.46
L31	3.46	L46	7.08	L61	0.67	L76	0.46
L32	2.79	L47	2.79	L62	2.17	L77	0.46
L33	2.79	L48	7.08	L63	0.46	L78	0.46
L34	2.46	L49	0.17	L64	3.46	L79	0.46
L35	2.46	L50	2.08	L65	2.79	L80	0.46
L36	1.33	L51	2.92	L66	2.79	L81	0.46
L37	1.33	L52	2.92	L67	2.46	L82	0.46
L38	1.71	L53	0.46	L68	1.33	L83	0.46
L39	2.17	L54	3.46	L69	0.46	L84	0.46
L40	6.98	L55	2.79	L70	0.46	L85	0.46
L41	4.46	L56	2.79	L71	0.46	L86	0.46
L42	8.25	L57	2.46	L72	0.46	L87	0.46
L43	4.46	L58	1.33	L73	0.46	L88	0.46
L44	5.67	L59	0.67	L74	0.46	L89	0.46
L45	2.54	L60	6.62	L75	0.46	L90	0.46
L46	7.08	L61	0.67	L76	0.46	L91	0.46
L47	2.79	L62	2.17	L77	0.46	L92	0.46
L48	7.08	L63	0.46	L78	0.46	L93	0.46
L49	0.17	L64	3.46	L79	0.46	L94	0.46
L50	2.08	L65	2.79	L80	0.46	L95	0.46
L51	2.92	L66	2.79	L81	0.46	L96	0.46
L52	2.92	L67	2.46	L82	0.46	L97	0.46
L53	0.46	L68	1.33	L83	0.46	L98	0.46
L54	3.46	L69	0.46	L84	0.46	L99	0.46
L55	2.79	L70	0.46	L85	0.46	L100	0.46
L56	2.79	L71	0.46	L86	0.46	L101	0.46
L57	2.46	L72	0.46	L87	0.46	L102	0.46
L58	1.33	L73	0.46	L88	0.46	L103	0.46
L59	0.67	L74	0.46	L89	0.46	L104	0.46
L60	6.62	L75	0.46	L90	0.46	L105	0.46
L61	0.67	L76	0.46	L91	0.46	L106	0.46
L62	2.17	L77	0.46	L92	0.46	L107	0.46
L63	0.46	L78	0.46	L93	0.46	L108	0.46
L64	3.46	L79	0.46	L94	0.46	L109	0.46
L65	2.79	L80	0.46	L95	0.46	L110	0.46
L66	2.79	L81	0.46	L96	0.46	L111	0.46
L67	2.46	L82	0.46	L97	0.46	L112	0.46
L68	1.33	L83	0.46	L98	0.46	L113	0.46
L69	0.46	L84	0.46	L99	0.46	L114	0.46
L70	0.46	L85	0.46	L100	0.46	L115	0.46
L71	0.46	L86	0.46	L101	0.46	L116	0.46
L72	0.46	L87	0.46	L102	0.46	L117	0.46
L73	0.46	L88	0.46	L103	0.46	L118	0.46
L74	0.46	L89	0.46	L104	0.46	L119	0.46
L75	0.46	L90	0.46	L105	0.46	L120	0.46
L76	0.46	L91	0.46	L106	0.46	L121	0.46
L77	0.46	L92	0.46	L107	0.46	L122	0.46
L78	0.46	L93	0.46	L108	0.46	L123	0.46
L79	0.46	L94	0.46	L109	0.46	L124	0.46
L80	0.46	L95	0.46	L110	0.46	L125	0.46
L81	0.46	L96	0.46	L111	0.46	L126	0.46
L82	0.46	L97	0.46	L112	0.46	L127	0.46
L83	0.46	L98	0.46	L113	0.46	L128	0.46
L84	0.46	L99	0.46	L114	0.46	L129	0.46
L85	0.46	L100	0.46	L115	0.46	L130	0.46
L86	0.46	L101	0.46	L116	0.46	L131	0.46
L87	0.46	L102	0.46	L117	0.46	L132	0.46
L88	0.46	L103	0.46	L118	0.46	L133	0.46
L89	0.46	L104	0.46	L119	0.46	L134	0.46
L90	0.46	L105	0.46	L120	0.46	L135	0.46
L91	0.46	L106	0.46	L121	0.46	L136	0.46
L92	0.46	L107	0.46	L122	0.46	L137	0.46
L93	0.46	L108	0.46	L123	0.46	L138	0.46
L94	0.46	L109	0.46	L124	0.46	L139	0.46
L95	0.46	L110	0.46	L125	0.46	L140	0.46
L96	0.46	L111	0.46	L126	0.46	L141	0.46
L97	0.46	L112	0.46	L127	0.46	L142	0.46
L98	0.46	L113	0.46	L128	0.46	L143	0.46
L99	0.46	L114	0.46	L129	0.46	L144	0.46
L100	0.46	L115	0.46	L130	0.46	L145	0.46
L101	0.46	L116	0.46	L131	0.46	L146	0.46
L102	0.46	L117	0.46	L132	0.46	L147	0.46
L103	0.46	L118	0.46	L133	0.46	L148	0.46
L104	0.46	L119	0.46	L134	0.46	L149	0.46
L105	0.46	L120	0.46	L135	0.46	L150	0.46
L106	0.46	L121	0.46	L136	0.46	L151	0.46
L107	0.46	L122	0.46	L137	0.46	L152	0.46
L108	0.46	L123	0.46	L138	0.46	L153	0.46
L109	0.46	L124	0.46	L139	0.46	L154	0.46
L110	0.46	L125	0.46	L140	0.46	L155	0.46
L111	0.46	L126	0.46	L141	0.46	L156	0.46
L112	0.46	L127	0.46	L142	0.46	L157	0.46
L113	0.46	L128	0.46	L143	0.46	L158	0.46
L114	0.46	L129	0.46	L144	0.46	L159	0.46
L115	0.46	L130	0.46	L145	0.46	L160	0.46
L116	0.46	L131	0.46	L146	0.46	L161	0.46
L117	0.46	L132	0.46	L147	0.46	L162	0.46
L118	0.46	L133	0.46	L148	0.46	L163	0.46
L119	0.46	L134	0.46	L149	0.46	L164	0.46
L120	0.46	L135	0.46	L150	0.46	L165	0.46
L121	0.46	L136	0.46	L151	0.46	L166	0.46
L122	0.46	L137	0.46	L152	0.46	L167	0.46
L123	0.46	L138	0.46	L153	0.46	L168	0.46
L124	0.46	L139	0.46	L154	0.46	L169	0.46
L125	0.46	L140	0.46	L155	0.46	L170	0.46
L126	0.46	L141	0.46	L156	0.46	L171	0.46
L127	0.46	L142	0.46	L157	0.46	L172	0.46
L128	0.46	L143	0.46	L158	0.46	L173	0.46
L129	0.46	L144	0.46	L159	0.46	L174	0.46
L130	0.46	L145	0.46	L160	0.46	L175	0.46
L131	0.46	L146	0.46	L161	0.46	L176	0.46
L132	0.46	L147	0.46	L162	0.46	L177	0.46
L133	0.46	L148	0.46	L163	0.46	L178	0.46
L134	0.46	L149	0.46	L164	0.46	L179	0.46
L135	0.46	L150	0.46	L165	0.46	L180	0.46
L136	0.46	L151	0.46	L166	0.46	L181	0.46
L137	0.46	L152	0.46	L167	0.46	L182	0.46
L138	0.46	L153	0.46	L168	0.46	L183	0.46
L139	0.46	L154	0.46	L169	0.46	L184	0.46
L140	0.46	L155	0.46	L170	0.46	L185	0.46
L141	0.46	L156	0.46	L171	0.46	L186	0.46
L142	0.46	L157	0.46	L172	0.46	L187	0.46
L143	0.46	L158	0.46	L173	0.46	L188	0.46
L144	0.46	L159	0.46	L174	0.46	L189	0.46
L145	0.46	L160	0.46	L175	0.46	L190	0.46
L146	0.46	L161	0.46	L176	0.46	L191	0.46
L147	0.46	L162	0.46	L177	0.46	L192	0.46
L148	0.46	L163	0.46	L178	0.46	L193	0.46
L149	0.46	L164	0.46	L179	0.46	L194	0.46
L150	0.46	L165	0.46	L180	0.46	L195	0.46
L151	0.46	L166	0.46	L181	0.46	L196	



COUNTY RECORDER

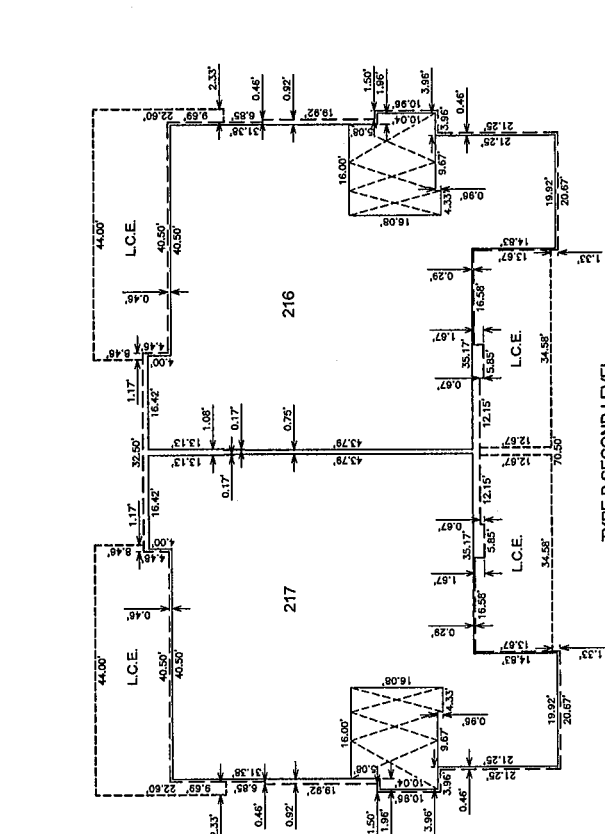

TYPE B SECOND LEVEL

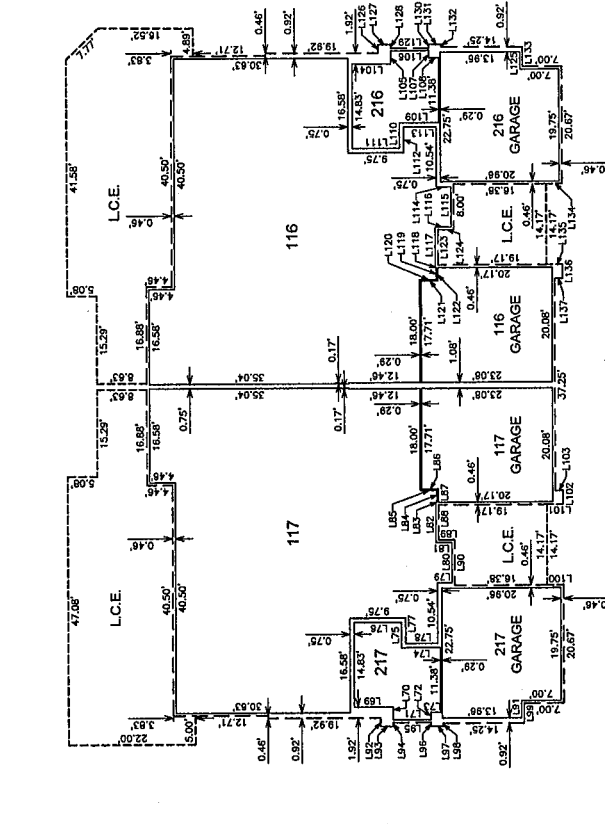

TYPE B FIRST LEVEL

- LEGEND**
- INDICATES INTERIOR BOUNDARY
 - INDICATES EXTERIOR FACE
 - INDICATES FLOOR LIMITS
 - INDICATES OPEN TO FLOOR BELOW

SINGLE FLOOR UNIT DATA TABLE

UNIT	SQUARE FEET	L.B.E.	U.B.E.
117	2432	457	1377.68
116	2432	457	1377.68

TWO FLOOR UNIT DATA TABLE

UNIT	1ST FLOOR	2ND FLOOR	TOTAL	GARAGE	L.B.E.	U.B.E.
217	211	3122	3333	456	1379.05	1389.14
216	211	3122	3333	456	1379.05	1389.14

LINE TABLE

NO.	LENGTH
L123	6.17
L124	2.79
L125	3.00
L126	1.50
L127	2.17
L128	0.67
L129	8.62
L130	0.67
L131	3.46
L132	0.48
L133	3.46
L134	2.79
L135	2.79
L136	2.46
L137	1.33

LINE TABLE

NO.	LENGTH
L105	2.26
L106	6.62
L107	1.29
L108	1.71
L109	6.88
L110	4.46
L111	6.25
L112	4.46
L113	5.67
L114	2.54
L115	7.08
L116	2.79
L117	7.08
L118	0.17
L119	2.08
L120	2.92
L121	2.92
L122	2.38

LINE TABLE

NO.	LENGTH
L87	2.38
L88	6.17
L89	2.79
L90	8.00
L91	3.00
L92	1.50
L93	2.17
L94	0.67
L95	6.62
L96	0.67
L97	2.17
L98	0.50
L99	3.46
L100	2.79
L101	2.79
L102	2.46
L103	1.33
L104	6.79

LINE TABLE

NO.	LENGTH
L68	6.79
L70	2.29
L71	6.62
L72	1.29
L73	1.71
L74	6.88
L75	4.46
L76	8.25
L77	4.46
L78	5.67
L79	2.54
L80	7.08
L81	2.79
L82	7.08
L83	0.17
L84	2.08
L85	2.92
L86	2.92

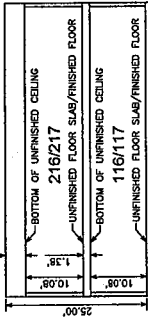

TYPE B VERTICAL SCHEMATIC



SCALE: 1" = 10'

UNIT PLANS



COUNTY RECORDER

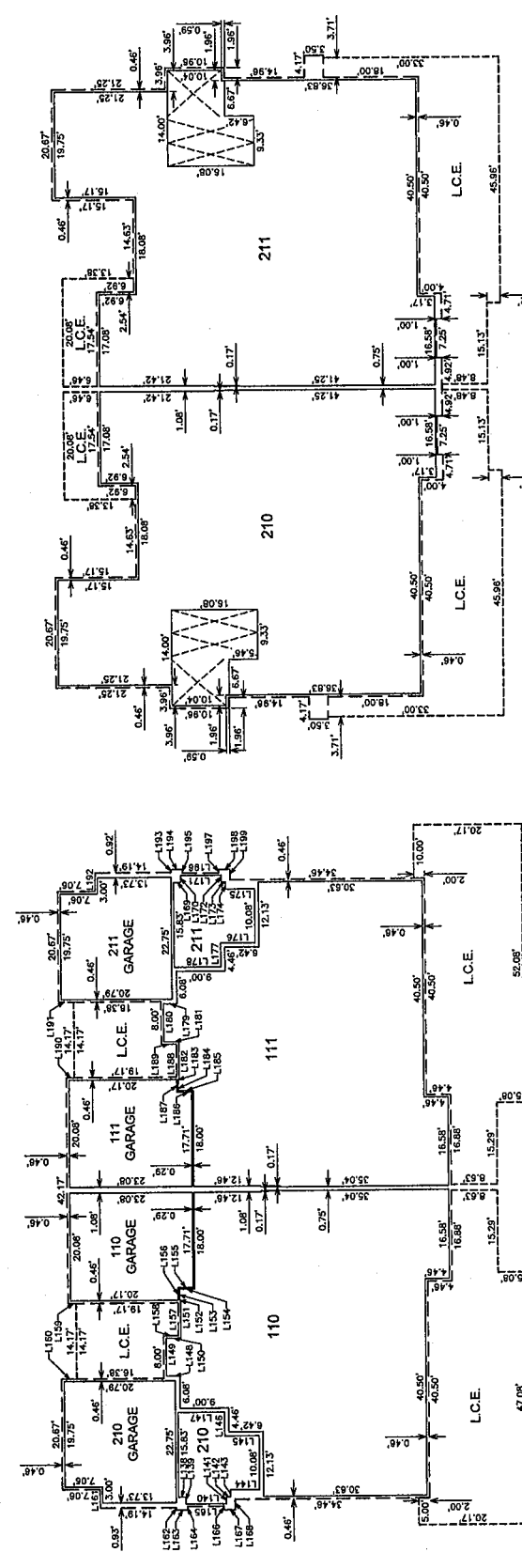

TYPE C SECOND LEVEL

TYPE C FIRST LEVEL

- LEGEND**
- INDICATES INTERIOR BOUNDARY
 - INDICATES EXTERIOR FACE
 - INDICATES FLOOR LIMITS
 - INDICATES OPEN TO FLOOR BELOW

SINGLE FLOOR UNIT DATA TABLE			
UNIT	TOTAL SQUARE FEET	GARAGE	L.B.E. U.B.E.
110	2435	457	1372.70 1382.78
111	2435	457	1372.70 1382.78
112	2435	457	1372.70 1382.78
113	2435	457	1372.70 1382.78
115	2435	457	1372.70 1382.78

TWO FLOOR UNIT DATA TABLE					
UNIT	1ST FLOOR SQUARE FEET	2ND FLOOR SQUARE FEET	TOTAL SQUARE FEET	GARAGE	L.B.E. U.B.E.
210	2435	457	2892	452	1384.16 1394.24
211	2435	457	2892	452	1384.16 1394.24
212	2435	457	2892	452	1384.16 1394.24
213	2435	457	2892	452	1384.16 1394.24
214	2435	457	2892	452	1384.16 1394.24
215	2435	457	2892	452	1384.16 1394.24

LINE TABLE	
NO.	LENGTH
L186	2.92
L187	2.38
L188	6.17
L189	2.79
L190	1.46
L191	2.78
L192	3.48
L193	0.50
L194	2.19
L195	0.67
L196	6.71
L197	0.67
L198	2.08
L199	1.96

LINE TABLE	
NO.	LENGTH
L170	1.29
L171	7.50
L172	1.29
L173	0.75
L174	1.29
L175	5.46
L176	6.42
L177	4.46
L178	6.71
L179	2.54
L180	7.08
L181	2.79
L182	7.08
L183	0.17
L184	2.08
L185	3.92

LINE TABLE	
NO.	LENGTH
L154	2.92
L155	2.92
L156	2.38
L157	6.17
L158	2.79
L159	1.46
L160	2.78
L161	3.46
L162	0.46
L163	2.19
L164	0.67
L165	6.71
L166	0.67
L167	2.08
L168	1.96
L169	1.42

LINE TABLE	
NO.	LENGTH
L138	1.42
L139	1.29
L140	7.50
L141	1.29
L142	0.75
L143	1.28
L144	5.46
L145	6.42
L146	4.46
L147	6.71
L148	2.54
L149	7.08
L150	2.79
L151	7.08
L152	0.17
L153	2.08

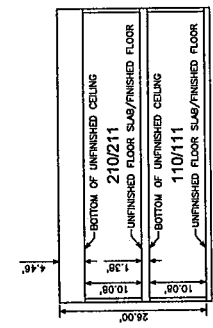

TYPE C VERTICAL SCHEMATIC



SEE SHEET 1 FOR LEGEND AND SEE SHEET 2 FOR CURVE TABLE

TYPE C UNIT PLANS



COUNTY RECORDER

NO.	REVISION	DATE

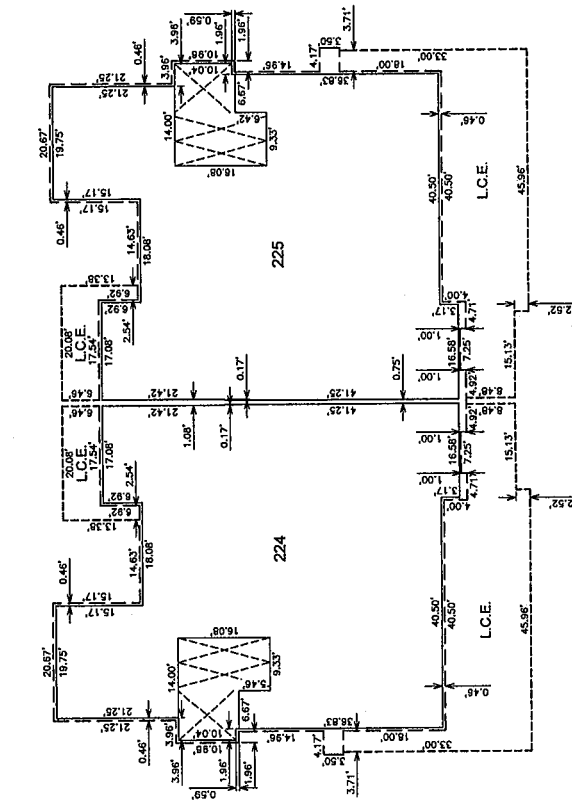

TYPE D SECOND LEVEL

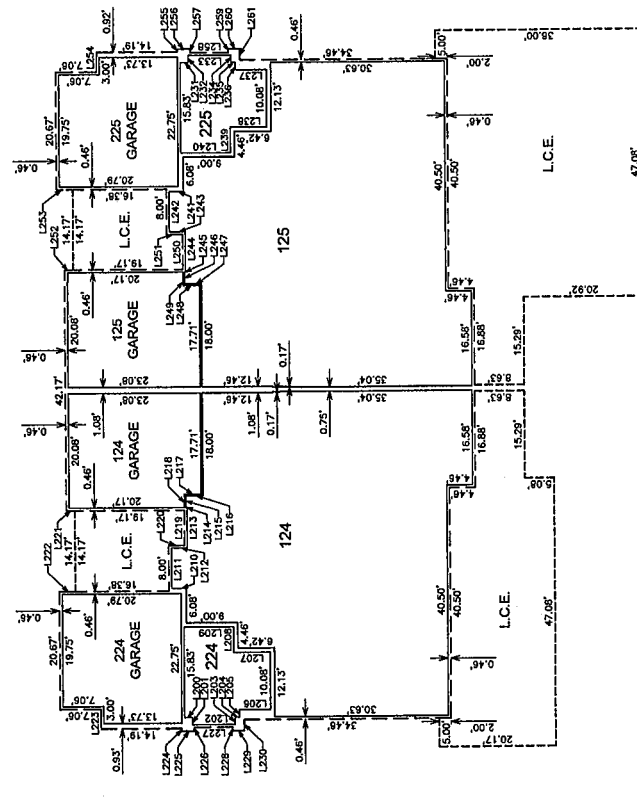

TYPE D FIRST LEVEL

- LEGEND**
- INDICATES INTERIOR BOUNDARY
 - INDICATES EXTERIOR FACE
 - INDICATES FLOOR LIMITS
 - INDICATES OPEN TO FLOOR BELOW

SINGLE FLOOR UNIT DATA TABLE

UNIT	SQUARE FEET	L.B.E.	U.B.E.
224	2455	1362.70	1376.78
225	2455	1362.70	1376.78

TWO FLOOR UNIT DATA TABLE

UNIT	1ST FLOOR	2ND FLOOR	TOTAL	GARAGE	L.B.E.	U.B.E.
224	2455	2455	4910	452	1376.78	1386.24
225	2455	2455	4910	452	1376.78	1386.24

LINE TABLE

NO.	LENGTH
L248	2.92
L249	2.38
L250	6.17
L251	2.79
L252	1.46
L253	2.79
L254	3.46
L255	0.50
L256	2.19
L257	0.87
L258	6.71
L259	0.67
L260	2.08
L261	1.96

LINE TABLE

NO.	LENGTH
L232	1.29
L233	7.50
L234	1.29
L235	0.75
L236	1.29
L237	5.46
L238	6.42
L239	4.48
L240	8.71
L241	2.54
L242	7.08
L243	2.79
L244	7.08
L245	0.17
L246	2.08
L247	2.92

LINE TABLE

NO.	LENGTH
L200	1.42
L201	1.29
L202	7.50
L203	1.29
L204	0.75
L205	1.29
L206	5.46
L207	6.42
L208	4.48
L209	8.71
L210	2.54
L211	7.08
L212	2.79
L213	7.08
L214	0.17
L215	2.08
L216	1.42

COUNTY RECORDER

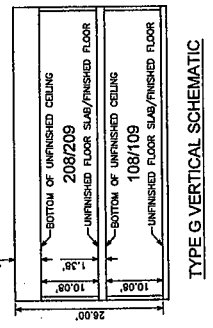
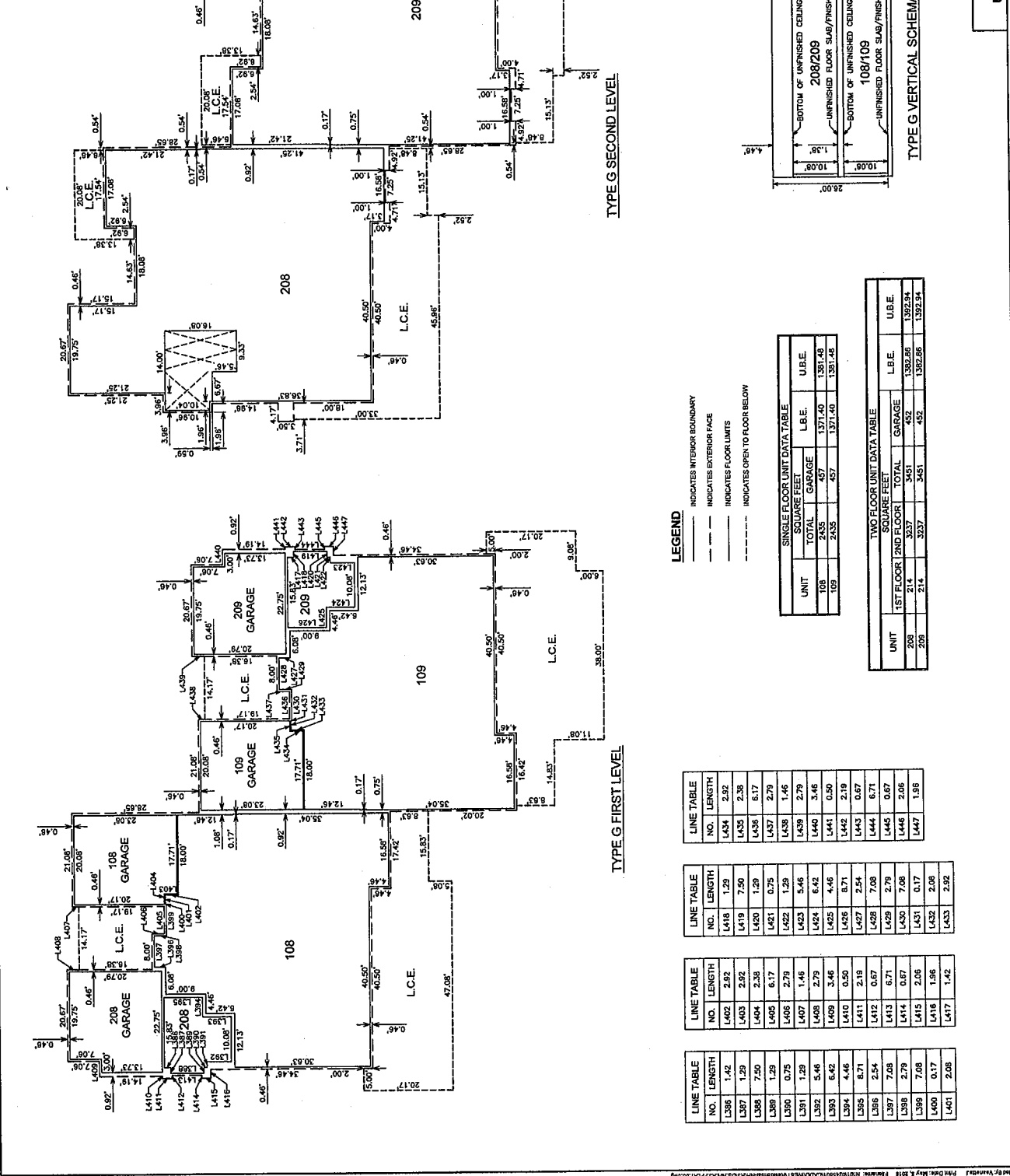

LEGEND

- INDICATES INTERIOR BOUNDARY
- - - INDICATES EXTERIOR FACE
- · · INDICATES FLOOR LIMITS
- - - INDICATES OPEN TO FLOOR BELOW

SINGLE FLOOR UNIT DATA TABLE			
UNIT	SQUARE FEET	L.B.E.	U.B.E.
108	2455	457	1371.40
109	2455	457	1371.40
208	2455	457	1371.40

TWO FLOOR UNIT DATA TABLE				
UNIT	1ST FLOOR	2ND FLOOR	TOTAL	U.B.E.
208	2414	3537	5951	1382.84
108	2414	3537	5951	1382.84
209	2414	3537	5951	1382.84

LINE TABLE	
NO.	LENGTH
L385	1.42
L387	1.29
L388	7.50
L389	1.29
L390	0.75
L391	1.29
L392	5.46
L393	6.42
L394	4.46
L395	6.71
L396	2.54
L397	7.08
L398	2.79
L399	7.08
L400	0.17
L401	2.08

LINE TABLE	
NO.	LENGTH
L402	2.92
L403	2.92
L404	2.38
L405	6.17
L406	1.46
L407	1.46
L408	2.79
L409	3.46
L410	0.50
L411	2.19
L412	0.67
L413	6.71
L414	0.67
L415	2.08
L416	1.96
L417	1.42

LINE TABLE	
NO.	LENGTH
L418	1.29
L419	7.50
L420	1.29
L421	0.75
L422	1.29
L423	5.46
L424	6.42
L425	4.46
L426	6.71
L427	2.54
L428	7.08
L429	2.79
L430	0.17
L431	0.17
L432	2.08
L433	2.92

LINE TABLE	
NO.	LENGTH
L434	2.92
L435	2.38
L436	6.17
L437	2.79
L438	1.46
L439	2.79
L440	3.46
L441	0.50
L442	2.19
L443	0.67
L444	6.71
L445	0.67
L446	2.08
L447	1.96