

# FINAL MAP

## "MOUNTAIN SHADOW RESORT UNIT 2 - AMENDED VII"

A LOT LINE ADJUSTMENT OF LOT 128 OF "MOUNTAIN SHADOW RESORT UNIT 2 AMENDED" AS RECORDED IN BOOK 95 OF MAPS, PAGE 3 M.C.R. & LOT 128-A, LOT 129, LOT 131, LOT 132, LOT 133, LOT 134, LOT 135 AND TRACT "A" OF "MOUNTAIN SHADOW RESORT UNIT 2 - AMENDED VI" AS RECORDED IN BOOK 1210 OF MAPS, PAGE 31 M.C.R. AND SITUATED IN THE SOUTHEAST QUARTER OF SECTION 8, TOWNSHIP 2 NORTH, RANGE 4 EAST OF THE GILA AND SALT RIVER BASE AND MERIDIAN, MARICOPA COUNTY, ARIZONA

### ZONING:

EXISTING ZONING - SUP - RESORT

### UTILITY PROVIDERS

WATER - EPCOR WATER  
SEWER - CITY OF PHOENIX  
ELECTRIC - ARIZONA PUBLIC SERVICE  
TELEPHONE - CENTURYLINK  
GAS - SOUTHWEST GAS  
CABLE TELEVISION - COX COMMUNICATIONS

### ENGINEER

COE & VAN LOO CONSULTANTS  
4550 NORTH 12TH STREET  
PHOENIX, ARIZONA 85014  
PHONE: (602) 264-6831  
FAX: (602) 264-6831  
CONTACT: FRED E. FLEET, P.E.

### BASIS OF BEARING

THE NORTH LINE OF THE EAST HALF OF THE SOUTHEAST QUARTER OF SECTION 8, T. 2 N., R. 4 E. USING A BEARING OF NORTH 90°00'00" EAST.

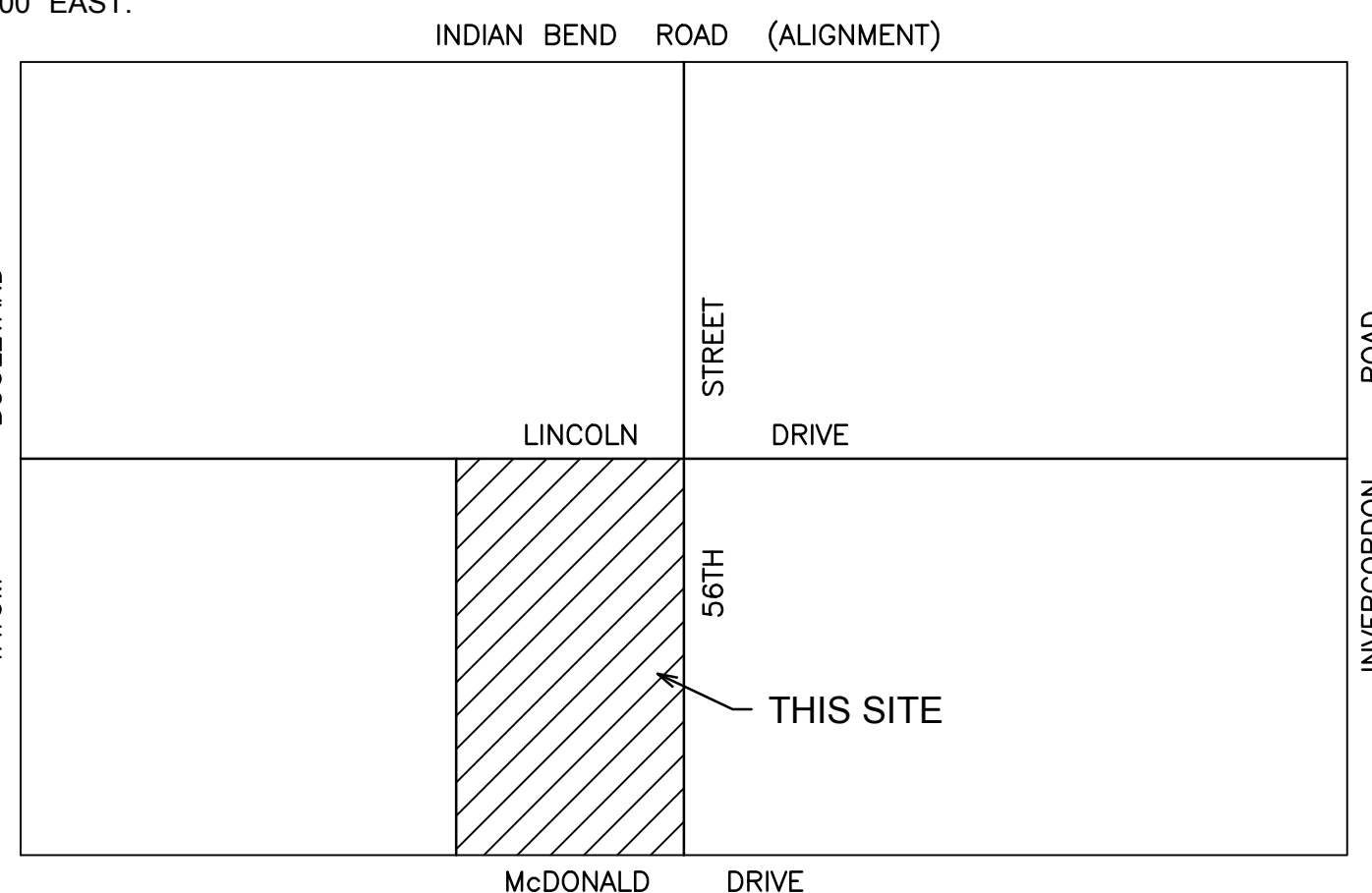

### VICINITY MAP

(NOT-TO-SCALE)

### SHEET INDEX

- 1 - COVER
- 2 - DETAILS, AREA TABLE, AND LEGEND
- 3 - FINAL MAP

### ACKNOWLEDGEMENT

STATE OF ARIZONA )  
 )SS  
COUNTY OF MARICOPA )

ON THIS \_\_\_\_\_ DAY OF \_\_\_\_\_, 2015, BEFORE ME, THE UNDERSIGNED NOTARY PUBLIC IN AND FOR SAID STATE, PERSONALLY APPEARED KRISTOPHER L. HARMAN, PERSONALLY KNOWN TO ME (OR PROVED TO ME ON THE BASIS OF SATISFACTORY EVIDENCE) TO BE THE PERSON WHOSE NAME IS SUBSCRIBED TO THE WITHIN INSTRUMENT AND ACKNOWLEDGED TO ME THAT HE/SHE EXECUTED THE SAME IN HIS/HER AUTHORIZED CAPACITY, AND THAT BY HIS/HER SIGNATURE ON THE INSTRUMENT THE PERSON, OR THE ENTITY UPON BEHALF OF WHICH THE PERSON ACTED, EXECUTED THE INSTRUMENT.

WITNESS MY HAND AND OFFICIAL SEAL

NOTARY PUBLIC \_\_\_\_\_

### ACKNOWLEDGEMENT

STATE OF CALIFORNIA )  
 )SS  
COUNTY OF ORANGE )

ON \_\_\_\_\_, BEFORE ME, ANN M. VERA, A NOTARY PUBLIC, PERSONALLY APPEARED ROBERT A. FLAXMAN, WHO PROVED TO ME ON THE BASIS OF SATISFACTORY EVIDENCE TO BE THE PERSON WHOSE NAME IS SUBSCRIBED TO THE WITHIN INSTRUMENT AND ACKNOWLEDGED TO ME THAT HE EXECUTED THE SAME IN HIS AUTHORIZED CAPACITY, AND THAT BY HIS SIGNATURE ON THE INSTRUMENT THE PERSON, OR THE ENTITY UPON BEHALF OF WHICH THE PERSON ACTED, EXECUTED THE INSTRUMENT.

I CERTIFY UNDER PENALTY OF PERJURY UNDER THE LAWS OF THE STATE OF CALIFORNIA THAT THE FOREGOING PARAGRAPH IS TRUE AND CORRECT.

WITNESS MY HAND AND OFFICIAL SEAL

SIGNATURE \_\_\_\_\_  
ANN M. VERA

### APPROVALS

APPROVED BY THE TOWN ENGINEER AND THE PLANNING DIRECTOR OF THE TOWN OF PARADISE VALLEY, THIS \_\_\_\_\_ DAY OF \_\_\_\_\_ OF 2015.

BY: \_\_\_\_\_  
TOWN ENGINEER

PLANNING DIRECTOR \_\_\_\_\_

### DECLARATION

STATE OF ARIZONA )  
 )SS  
COUNTY OF MARICOPA )

KNOW ALL MEN BY THESE PRESENTS:

THAT MTS LAND, LLC, A DELAWARE LIMITED LIABILITY COMPANY, MS RESORT OWNER, LLC, A DELAWARE LIMITED LIABILITY COMPANY, MS CONDO-HOTEL OWNER, LLC, A DELAWARE LIMITED LIABILITY COMPANY, AND MOUNTAIN SHADOWS MASTER ASSOCIATION, INC., AN ARIZONA NONPROFIT CORPORATION (COLLECTIVELY, "OWNERS.") HAVE RESUBDIVIDED UNDER THE NAME OF "MOUNTAIN SHADOW RESORT - UNIT 2 AMENDED VII" A LOT LINE ADJUSTMENT OF LOT 128 OF "MOUNTAIN SHADOW RESORT UNIT TWO - AMENDED VI" AS RECORDED IN BOOK 95 OF MAPS, PAGE 3 M.C.R. AND LOT 128-A, LOT 129, LOT 131, LOT 132, LOT 133, LOT 134, LOT 135 AND TRACT "A" OF "MOUNTAIN SHADOW RESORT UNIT 2 - AMENDED VI" AS RECORDED IN BOOK 1210 OF MAPS, PAGE 31 M.C.R. AND SITUATED IN THE SOUTHEAST QUARTER OF SECTION 8, TOWNSHIP 2 NORTH, RANGE 4 EAST OF THE GILA & SALT RIVER BASE AND MERIDIAN, MARICOPA COUNTY, ARIZONA, AS SHOWN AND MAPPED HEREON AND HEREBY PUBLISH THIS MAP AS AND FOR THE MAP OF SAID "MOUNTAIN SHADOW RESORT UNIT 2 - AMENDED VII" AND THAT THIS MAP SETS FORTH THE LOCATION AND GIVES THE DIMENSIONS OF THE LOTS AND TRACT CONSTITUTING SAME AND THAT EACH LOT AND TRACT SHALL BE KNOWN BY THE NUMBER OR LETTER GIVEN EACH RESPECTIVELY ON SAID MAP.

OWNERS HEREBY DEDICATE TO WATER, SEWER, GAS, ELECTRIC, TELEPHONE, AND CABLE TELEVISION UTILITY PROVIDERS AND RESERVE FOR THE "MOUNTAIN SHADOWS MASTER ASSOCIATION, INC." HOMEOWNERS ASSOCIATION OR ANY SUBASSOCIATION DESIGNATED BY SUCH MASTER HOMEOWNERS ASSOCIATION (COLLECTIVELY, THE "ASSOCIATION") AN UNDERGROUND EASEMENT UNDER AND ACROSS THOSE AREAS (TO THE EXTENT EACH OWNER OWNS SUCH AREAS) SHOWN AS UTILITY EASEMENTS DEDICATED HEREON FOR THE INSTALLATION, MAINTENANCE, REPAIR, AND REMOVAL OF UNDERGROUND PUBLIC AND PRIVATE WATER LINES, PRIVATE SEWER LINES, GAS, ELECTRIC, TELEPHONE, AND CABLE TELEVISION UTILITIES STRICTLY AS NECESSARY TO PROVIDE SUCH UTILITY SERVICES AND SOLELY FOR THE PURPOSE OF PROVIDING SUCH UTILITY SERVICES TO OR FROM LOTS 128, 128-A, 129, 131, 132, 133, 134, 135, AND TRACT "A." THIS UNDERGROUND EASEMENT ALSO INCLUDES AN EASEMENT FOR ANY ABOVE-GROUND FACILITIES REQUIRED BY UTILITY PROVIDERS IN CONNECTION WITH THE UNDERGROUND UTILITIES. MAINTENANCE OF THE AREAS SUBJECT TO UTILITY EASEMENTS SHALL BE THE RESPONSIBILITY OF THE LOT OWNER, TRACT OWNER, OR ASSOCIATION, AS DETERMINED BY THE ASSOCIATION, PROVIDED THAT AFTER ANY INSTALLATION, MAINTENANCE, REPAIR, OR REMOVAL, ANY UTILITY PROVIDER THAT DISTURBS THE SURFACE OR SUBSURFACE OF THE GROUND SHALL BE RESPONSIBLE FOR RESTORING SUCH AREA TO SUBSTANTIALLY THE CONDITION THAT EXISTED PRIOR TO SUCH DISTURBANCE. THE PUBLIC UTILITY EASEMENTS PREVIOUSLY DEDICATED ON THE FINAL MAPS OF "MOUNTAIN SHADOWS RESORT UNIT 2 - AMENDED IV" AS RECORDED IN BOOK 1170 OF MAPS, PAGE 30 M.C.R., "MOUNTAIN SHADOWS RESORT UNIT 2 - AMENDED V" AS RECORDED IN BOOK 1206 OF MAPS, PAGE 6 M.C.R., AND "MOUNTAIN SHADOW RESORT UNIT 2 - AMENDED VI" AS RECORDED IN BOOK 1210 OF MAPS, PAGE 31 M.C.R. AS SHOWN ON SUCH PRIOR MAPS ARE HEREBY EXTINGUISHED AND SUPERSEDED BY THE UTILITY EASEMENTS DEDICATED IN THIS PARAGRAPH.

TRACT "A" IS DEDICATED AS A PRIVATE DRIVE TO PROVIDE PEDESTRIAN AND VEHICULAR INGRESS AND EGRESS TO AND FROM LOTS 128, 128-A, 129, 131, 132, 133, 134, 135, AND TRACT "A." A NONEXCLUSIVE EASEMENT FOR PEDESTRIAN AND VEHICULAR INGRESS AND EGRESS TO COMPLY WITH SECTION 8.1 OF THE SETTLEMENT AGREEMENT (EVIDENCED BY THE SECOND AMENDMENT TO MEMORANDUM REGARDING SETTLEMENT AGREEMENT AFFECTING REAL PROPERTY RECORDED AS DOCUMENT NO. 2015-0109494, M.C.R.) IS HEREBY CREATED OVER TRACT "A" SHOWN HEREON, AS SUCH TRACT "A" MAY BE MODIFIED FROM TIME TO TIME PURSUANT TO SUCH SECTION 8.1 BY THE OWNERS OF THE EXISTING TRACT "A" AND THE PROPOSED TRACT "A" IN THEIR SOLE DISCRETION, FOR THE BENEFIT OF THE 59 RESIDENTIAL LOTS OF MOUNTAIN SHADOW RESORT UNIT TWO - AMENDED, RECORDED ON JUNE 6, 1961, IN BOOK 95 OF MAPS, PAGE 3, M.C.R. AND THE MOUNTAIN SHADOWS WEST HOMEOWNERS ASSOCIATION, INC.

AN UNDERGROUND EASEMENT IS HEREBY DEDICATED TO WATER, SEWER, GAS, ELECTRIC, TELEPHONE, AND CABLE TELEVISION UTILITY PROVIDERS AND RESERVED FOR THE ASSOCIATION UNDER AND ACROSS TRACT "A" FOR THE INSTALLATION, MAINTENANCE, REPAIR, AND REMOVAL OF UNDERGROUND PUBLIC AND PRIVATE WATER LINES, PRIVATE SEWER LINES, GAS, ELECTRIC, TELEPHONE, AND CABLE TELEVISION UTILITIES STRICTLY AS NECESSARY TO PROVIDE SUCH UTILITY SERVICES AND SOLELY FOR THE PURPOSE OF PROVIDING SUCH UTILITY SERVICES TO OR FROM LOTS 128, 128-A, 129, 131, 132, 133, 134, 135, AND TRACT "A" AND FOR THE PURPOSE OF PROVIDING PUBLIC AND PRIVATE WATER LINES AND PRIVATE SEWER LINES TO OR FROM THE 59 RESIDENTIAL LOTS OF MOUNTAIN SHADOW RESORT UNIT TWO - AMENDED, RECORDED ON JUNE 6, 1961, IN BOOK 95 OF MAPS, PAGE 3, M.C.R. THIS UNDERGROUND EASEMENT ALSO INCLUDES AN EASEMENT FOR ANY ABOVE-GROUND FACILITIES REQUIRED BY UTILITY PROVIDERS IN CONNECTION WITH THE UNDERGROUND UTILITIES. AN EASEMENT FOR REFUSE COLLECTION AND EMERGENCY AND SIMILAR SERVICE TYPE VEHICLE ACCESS IS HEREBY DEDICATED OVER TRACT "A" TO THE TOWN OF PARADISE VALLEY AND OTHER EMERGENCY SERVICE PROVIDERS AND REFUSE COLLECTION PROVIDERS AND TO THE ASSOCIATION, WHICH ASSOCIATION ALSO BENEFITS.

TRACT "A" IS NOT DEDICATED FOR THE USE OF THE GENERAL PUBLIC. TRACT "A" SHALL BE OWNED AND MAINTAINED BY THE ASSOCIATION, PROVIDED THAT AFTER ANY INSTALLATION, MAINTENANCE, REPAIR, OR REMOVAL, ANY UTILITY PROVIDER THAT DISTURBS THE SURFACE OR SUBSURFACE OF THE GROUND SHALL BE RESPONSIBLE FOR RESTORING SUCH AREA TO SUBSTANTIALLY THE CONDITION THAT EXISTED PRIOR TO SUCH DISTURBANCE. NO DWELLING UNITS SHALL BE CONSTRUCTED ON TRACT "A." ONE OR MORE GUARDHOUSES AND ASSOCIATED IMPROVEMENTS MAY BE CONSTRUCTED ON TRACT "A."

COUNTY RECORDER



### DECLARATION - CONTINUED

AN EASEMENT FOR RELOCATED UNDERGROUND SEWER LINES (LISTED IN NO. 9 AND NO. 10 IN THE EASEMENT SCHEDULE) IS HEREBY DEDICATED TO SEWER UTILITY PROVIDERS UNDER AND ACROSS LOT 128-A, LOT 129, AND 131 AS DEPICTED HEREON FOR THE INSTALLATION, MAINTENANCE, REPAIR AND REMOVAL OF UNDERGROUND PRIVATE SEWER LINES PURSUANT TO THAT CERTAIN SEWER EASEMENT RELOCATION AND MAINTENANCE AGREEMENT RECORDED IN RECORDING NO. 2013-1074865, M.C.R. (THE "SEWER EASEMENT AGREEMENT"). THE UNDERGROUND EASEMENT ALSO INCLUDES AN EASEMENT FOR ANY ABOVE-GROUND FACILITIES REQUIRED BY SEWER UTILITY PROVIDERS IN CONNECTION WITH THE UNDERGROUND SEWER LINES. MAINTENANCE OF THE AREA SUBJECT TO THE FOREGOING EASEMENT SHALL BE THE RESPONSIBILITY OF THE LOT OWNER OR ASSOCIATION, AS DETERMINED BY THE ASSOCIATION, AND AS SET FORTH IN AND SUBJECT TO THE SEWER EASEMENT AGREEMENT, PROVIDED THAT AFTER ANY INSTALLATION, MAINTENANCE, REPAIR, OR REMOVAL, ANY SEWER UTILITY PROVIDER THAT DISTURBS THE SURFACE OR SUBSURFACE OF THE GROUND SHALL BE RESPONSIBLE FOR RESTORING SUCH AREA TO SUBSTANTIALLY THE CONDITION THAT EXISTED PRIOR TO SUCH DISTURBANCE. THIS EASEMENT FOR RELOCATED SEWER LINES IS IN ADDITION TO THE UTILITY CORRIDOR EASEMENT GRANTED IN THE MOUNTAIN SHADOWS WEST DECLARATION OF COVENANTS, CONDITIONS, RESTRICTIONS AND EASEMENTS RECORDED IN RECORDING NO. 2015-0109960, M.C.R., AND AMENDED IN RECORDING NO. 2015-\_\_\_\_\_, M.C.R., (THE "WEST DECLARATION") WHICH IS ALSO LISTED IN NO. 9 IN THE EASEMENT SCHEDULE. UPON THE RELOCATION OF SEWER LINES FROM THE EASEMENT LISTED AS NO. 8 IN THE EASEMENT SCHEDULE TO THE EASEMENT FOR RELOCATED SEWER LINES LISTED IN NO. 9 AND NO. 10 IN THE EASEMENT SCHEDULE, AND UPON COMPLIANCE WITH SECTION 1.2 OF THE SEWER EASEMENT AGREEMENT, THE EASEMENT LISTED AS NO. 8 IN THE EASEMENT SCHEDULE AND AS DEPICTED HEREON SHALL BE ABANDONED IN THE FUTURE AND ANY EASEMENT FOR SEWER PURPOSES AS IT PERTAINS TO THE UTILITY EASEMENT DEPICTED AS NO. 8 HEREON SHALL BE AUTOMATICALLY TERMINATED AND OF NO FURTHER FORCE AND EFFECT, AS SET FORTH IN AND SUBJECT TO THE SEWER EASEMENT AGREEMENT.

MTS LAND LLC, A DELAWARE LIMITED LIABILITY COMPANY  
MS RESORT OWNER, LLC, A DELAWARE LIMITED LIABILITY COMPANY  
MS CONDO-HOTEL OWNER, LLC, A DELAWARE LIMITED LIABILITY COMPANY  
MOUNTAIN SHADOWS MASTER ASSOCIATION, INC., AN ARIZONA NONPROFIT CORPORATION

### IN WITNESS WHEREOF:

MTS LAND LLC, A DELAWARE LIMITED LIABILITY COMPANY, AS OWNER, HAS CAUSED ITS NAME TO BE AFFIXED AND THE SAME TO BE ATTESTED BY THE SIGNATURE OF ROBERT A. FLAXMAN, ITS AUTHORIZED AGENT. DULY AUTHORIZED THIS \_\_\_\_\_ DAY OF \_\_\_\_\_, 2015.

BY: \_\_\_\_\_  
AUTHORIZED AGENT

### IN WITNESS WHEREOF:

MS RESORT OWNER, LLC, A DELAWARE LIMITED LIABILITY COMPANY, AS OWNER, HAS CAUSED ITS NAME TO BE AFFIXED AND THE SAME TO BE ATTESTED BY THE SIGNATURE OF KRISTOPHER L. HARMAN, ITS VICE PRESIDENT ON BEHALF OF THE COMPANY DULY AUTHORIZED THIS \_\_\_\_\_ DAY OF \_\_\_\_\_, 2015.

BY: \_\_\_\_\_  
KRISTOPHER L. HARMAN  
VICE PRESIDENT

### IN WITNESS WHEREOF:

MS CONDO-HOTEL OWNER, LLC, A DELAWARE LIMITED LIABILITY COMPANY, AS OWNER, HAS CAUSED ITS NAME TO BE AFFIXED AND THE SAME TO BE ATTESTED BY THE SIGNATURE OF KRISTOPHER L. HARMAN, ITS VICE PRESIDENT ON BEHALF OF THE COMPANY DULY AUTHORIZED THIS \_\_\_\_\_ DAY OF \_\_\_\_\_, 2015.

BY: \_\_\_\_\_  
KRISTOPHER L. HARMAN  
VICE PRESIDENT

### IN WITNESS WHEREOF:

MOUNTAIN SHADOWS MASTER ASSOCIATION, INC., AN ARIZONA NONPROFIT CORPORATION, AS OWNER, HAS CAUSED ITS NAME TO BE AFFIXED AND THE SAME TO BE ATTESTED BY THE SIGNATURE OF ROBERT A. FLAXMAN, ITS AUTHORIZED AGENT. DULY AUTHORIZED THIS \_\_\_\_\_ DAY OF \_\_\_\_\_, 2015.

BY: \_\_\_\_\_  
AUTHORIZED AGENT

### SURVEYOR'S CERTIFICATION

THIS IS TO CERTIFY THAT THE SURVEY AND RELOCATION OF THE LOT LINES DESCRIBED AND MAPPED HEREON WERE MADE UNDER MY DIRECTION DURING THE MONTH OF SEPTEMBER 2014, THAT THIS SURVEY IS COMPLETE AS SHOWN, THAT THE MONUMENTS AND LOT CORNERS SHOWN ACTUALLY EXIST OR WILL BE SET AS SHOWN, THAT THEIR POSITIONS ARE CORRECTLY SHOWN, AND THAT SAID MONUMENTS ARE SUFFICIENT TO ENABLE THE SURVEY TO BE RETRACED.

LARRY E. SULLIVAN, R.L.S. #22782

GROSS AREA = 55.394 ACRES

| DATE | REVISION | NO. |
|------|----------|-----|
|      |          |     |
|      |          |     |
|      |          |     |
|      |          |     |

FINAL MAP  
MOUNTAIN SHADOW RESORT  
UNIT - 2 AMENDED VII



SHEET 1 OF 3  
CVL Contact: R. WEED  
CVL Project #: 01-0245811  
CVL File #:



**CURVE TABLE**

| NO. | RADIUS | ARC    | DELTA      | TANGENT | CHORD  | CHORD-BEARING |
|-----|--------|--------|------------|---------|--------|---------------|
| 1   | 20.00  | 31.32  | 089°43'01" | 19.90   | 28.21  | S45°08'29.5"E |
| 2   | 20.00  | 24.26  | 069°30'46" | 13.88   | 22.80  | S35°02'22.0"E |
| 3   | 20.00  | 31.54  | 090°21'19" | 20.12   | 28.37  | S44°53'40.5"W |
| 4   | 284.00 | 427.00 | 086°08'44" | 265.51  | 387.90 | S13°26'02.0"E |
| 5   | 140.00 | 152.47 | 062°23'50" | 84.78   | 145.04 | S01°33'35.0"E |
| 6   | 294.00 | 264.00 | 051°27'00" | 141.65  | 255.22 | S07°02'00.0"E |
| 7   | 294.00 | 73.01  | 014°13'42" | 36.69   | 72.82  | S82°53'09.0"W |
| 8   | 458.00 | 769.56 | 096°16'20" | 511.10  | 682.17 | N41°51'50.0"W |
| 9   | 436.00 | 147.12 | 019°20'00" | 74.27   | 146.42 | N03°23'40.0"W |
| 10  | 360.00 | 277.01 | 044°05'13" | 145.77  | 270.22 | N08°58'56.5"E |
| 11  | 54.99  | 140.15 | 146°01'20" | 179.99  | 105.18 | N81°57'20.0"E |
| 12  | 10.00  | 15.71  | 090°00'00" | 10.00   | 14.14  | N45°00'00.0"E |
| 13  | 10.00  | 15.71  | 090°00'00" | 10.00   | 14.14  | N45°00'00.0"W |
| 14  | 64.00  | 133.64 | 119°38'20" | 110.05  | 110.65 | S30°10'50.0"E |
| 15  | 360.00 | 392.06 | 062°23'50" | 218.01  | 372.96 | S01°33'35.0"E |
| 16  | 74.00  | 158.55 | 122°45'30" | 135.61  | 129.92 | S28°37'15.0"W |
| 17  | 238.00 | 399.90 | 096°16'20" | 265.59  | 354.49 | N41°51'50.0"W |
| 18  | 656.00 | 221.35 | 019°20'00" | 111.74  | 220.31 | N03°23'40.0"W |
| 19  | 140.00 | 251.83 | 103°03'40" | 176.20  | 219.22 | N38°28'10.0"E |
| 20  | 34.00  | 53.24  | 089°43'01" | 33.83   | 47.96  | S45°08'29.5"E |
| 21  | 235.00 | 52.15  | 012°42'54" | 26.18   | 52.04  | S06°04'28.0"W |
| 22  | 30.00  | 31.93  | 060°58'28" | 17.66   | 30.44  | S30°29'14.0"W |
| 23  | 50.00  | 29.16  | 033°25'04" | 15.01   | 28.75  | S16°42'32.0"E |

**CURVE TABLE**

| NO. | RADIUS | ARC   | DELTA      | TANGENT | CHORD | CHORD-BEARING |
|-----|--------|-------|------------|---------|-------|---------------|
| 24  | 50.00  | 28.92 | 033°08'05" | 14.87   | 28.51 | S16°51'01.5"E |
| 25  | 515.00 | 78.78 | 008°45'52" | 39.47   | 78.70 | S04°39'55.0"E |
| 26  | 273.82 | 43.24 | 009°02'51" | 21.66   | 43.19 | S04°31'25.5"E |
| 27  | 91.26  | 26.11 | 016°23'36" | 13.15   | 26.02 | N00°57'36.0"E |
| 28  | 89.42  | 45.93 | 029°25'52" | 23.48   | 45.43 | N20°50'37.0"W |
| 29  | 70.00  | 40.44 | 033°05'59" | 20.80   | 39.88 | N19°00'32.5"W |
| 30  | 690.47 | 79.39 | 006°35'18" | 39.74   | 79.35 | N05°45'12.0"W |
| 31  | 485.00 | 74.19 | 008°45'52" | 37.17   | 74.12 | N04°39'55.0"W |
| 32  | 100.00 | 40.91 | 023°26'26" | 20.75   | 40.63 | N11°26'14.0"E |
| 33  | 50.00  | 14.97 | 017°09'27" | 7.54    | 14.92 | N14°34'43.5"E |
| 34  | 100.00 | 18.83 | 010°47'15" | 9.44    | 18.80 | N00°36'22.5"E |
| 35  | 24.50  | 40.53 | 094°47'15" | 26.64   | 36.07 | N42°36'22.5"E |
| 36  | 32.50  | 8.41  | 014°49'55" | 4.23    | 8.39  | S82°35'02.5"E |
| 37  | 32.50  | 8.41  | 014°49'55" | 4.23    | 8.39  | S82°35'02.5"E |
| 38  | 20.00  | 7.05  | 020°12'15" | 3.56    | 7.02  | S79°53'52.5"E |
| 39  | 20.00  | 31.51 | 090°16'59" | 20.10   | 28.35 | S44°51'30.5"W |
| 40  | 32.50  | 9.34  | 016°28'06" | 4.70    | 9.31  | N81°45'57.0"W |
| 41  | 32.50  | 9.34  | 016°28'06" | 4.70    | 9.31  | N81°45'57.0"W |
| 42  | 24.50  | 43.21 | 101°03'20" | 29.75   | 37.82 | N39°28'20.0"W |
| 43  | 276.00 | 54.62 | 011°20'19" | 27.40   | 54.53 | N05°23'10.5"E |
| 44  | 20.00  | 31.51 | 090°16'59" | 20.10   | 28.35 | N44°51'30.5"E |
| 45  | 20.00  | 25.62 | 073°23'42" | 14.91   | 23.90 | N27°39'00.0"E |

**COUNTY RECORDER**

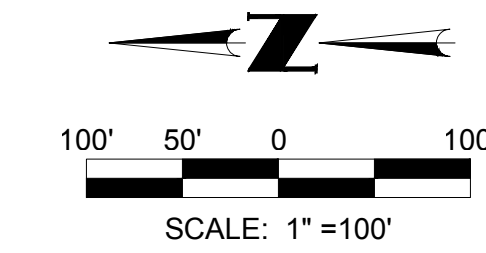

**Coe & Van Loo Consultants, Inc.**

**FINAL MAP**  
MOUNTAIN SHADOW RESORT  
UNIT - 2 AMENDED VII

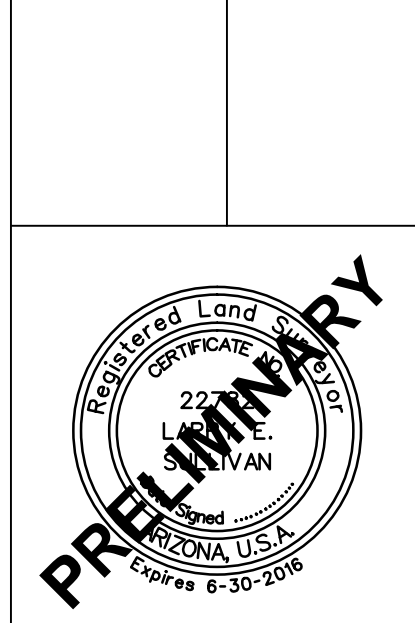

SHEET 3 OF 3  
CVL Contact: R. WEED  
CVL Project #: 01-0245811  
CVL File #:

CENTER SECTION 9  
T. 2 N., R. 4 E.  
FD. M.C.H.D. B.C. IN H.H.

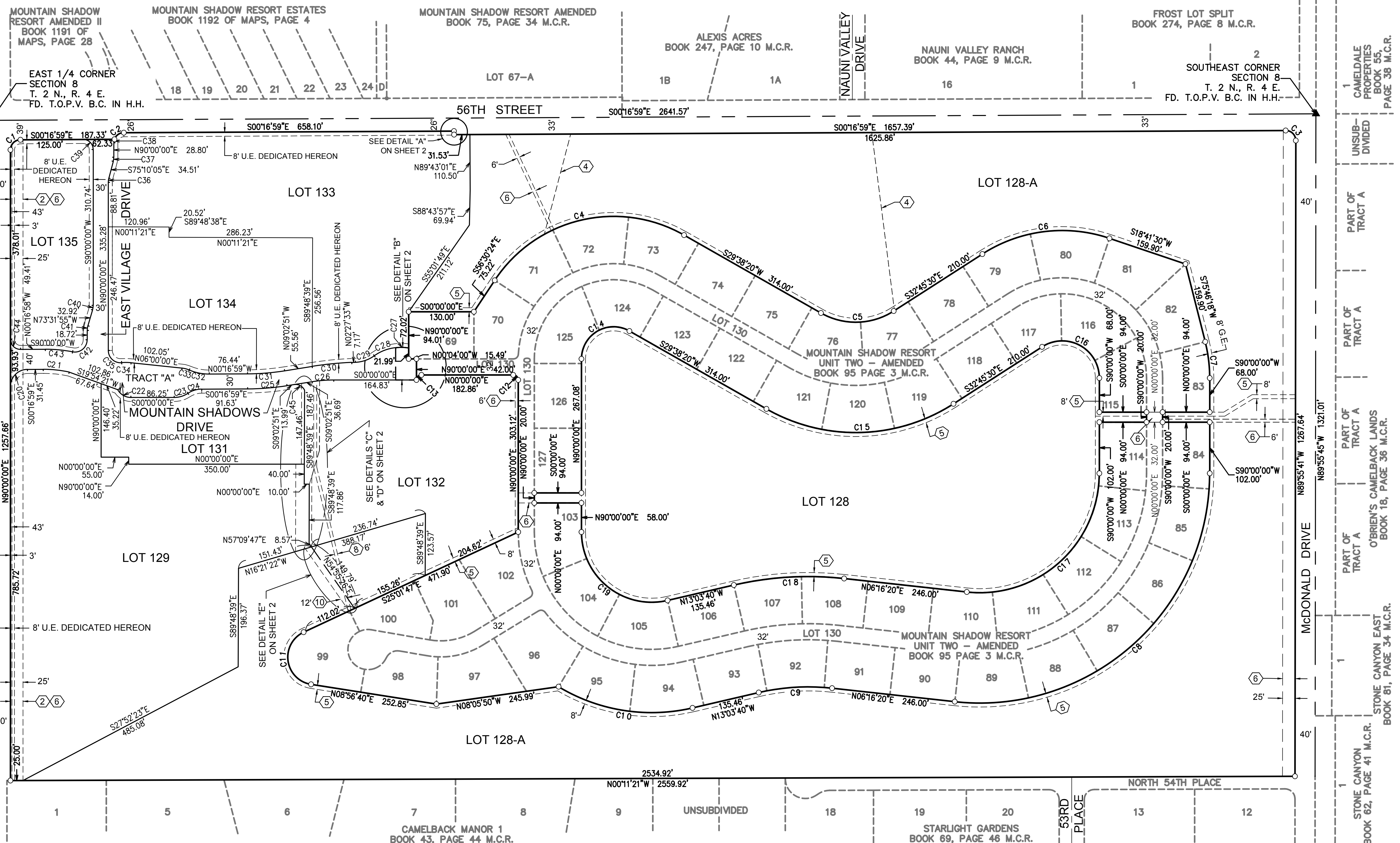

N:\01024581\1\CADD\AMENDED VILDS\FPLAT.S02.DWG MikeR June 4, 2015 - 2:36 PM



**LEGEND**

- ▲ FOUND OR SET MONUMENT AT SECTION OR 1/4 CORNER
- CORNER OF SUBDIVISION (CALCULATED POINT)
- CORNER OF SUBDIVISION FD. MONUMENT (1" PIPE)
- B.C. BRASS CAP
- FD. FOUND
- H.H. HAND HOLE
- T.O.P.V. TOWN OF PARADISE VALLEY
- M.C.H.D. MARICOPA COUNTY HIGHWAY DEPT.
- M.C. MARICOPA COUNTY
- G.E. GAS LINE EASEMENT
- U.E. UTILITY EASEMENT
- M.C.R. MARICOPA COUNTY RECORDS

| LOT TABLE |                    |              |
|-----------|--------------------|--------------|
| LOT NO.   | AREA (SQUARE FEET) | AREA (ACRES) |
| 128       | 409,590            | 9.403        |
| 128-A     | 1,080,938          | 24.815       |
| 129       | 297,302            | 6.825        |
| 131       | 58,254             | 1.337        |
| 132       | 137,505            | 3.157        |
| 133       | 201,606            | 4.628        |
| 134       | 109,309            | 2.509        |
| 135       | 68,106             | 1.564        |
| TRACT "A" | 50,357             | 1.156        |
| TOTAL     | 2,412,967          | 55.394       |

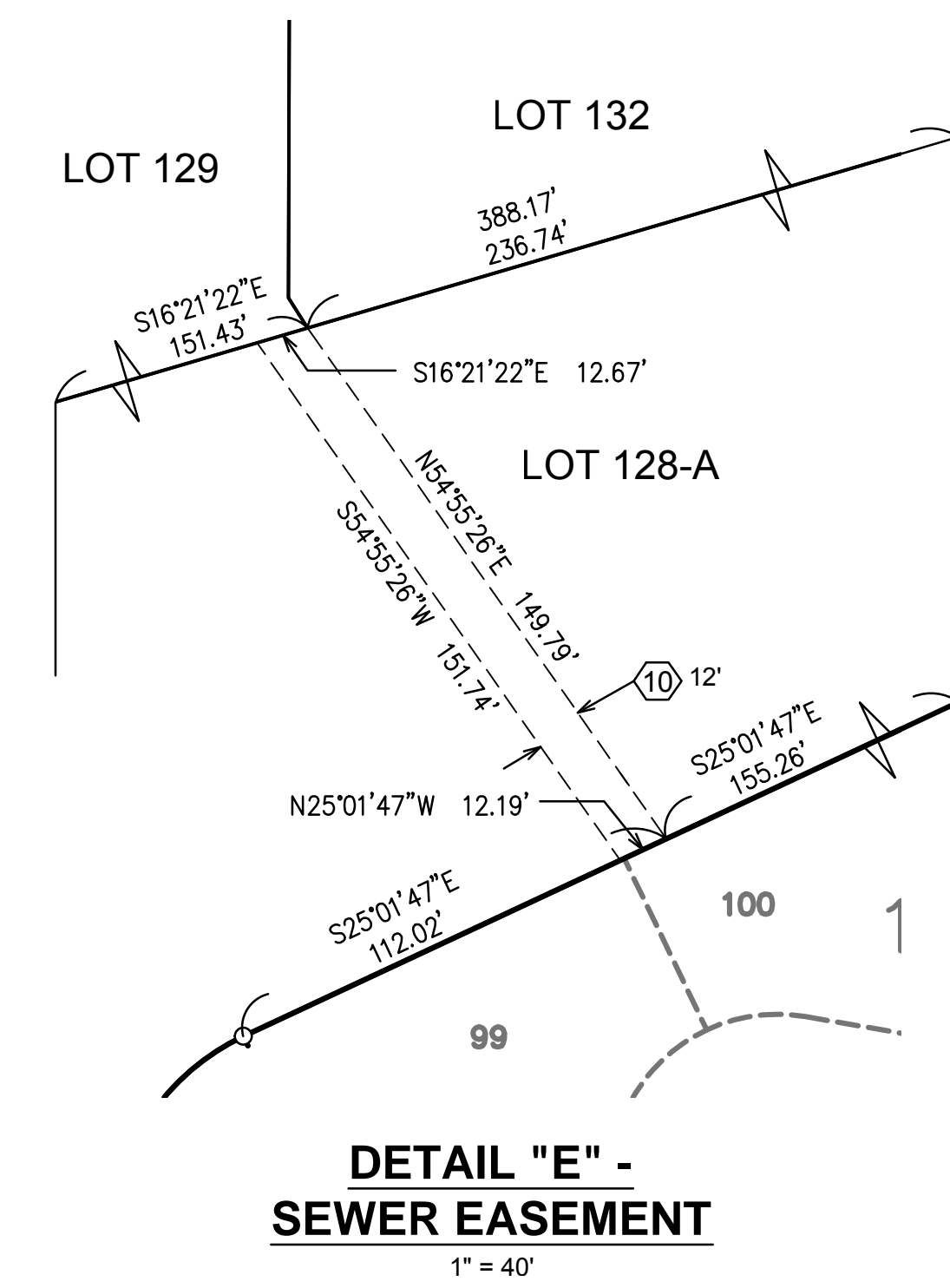
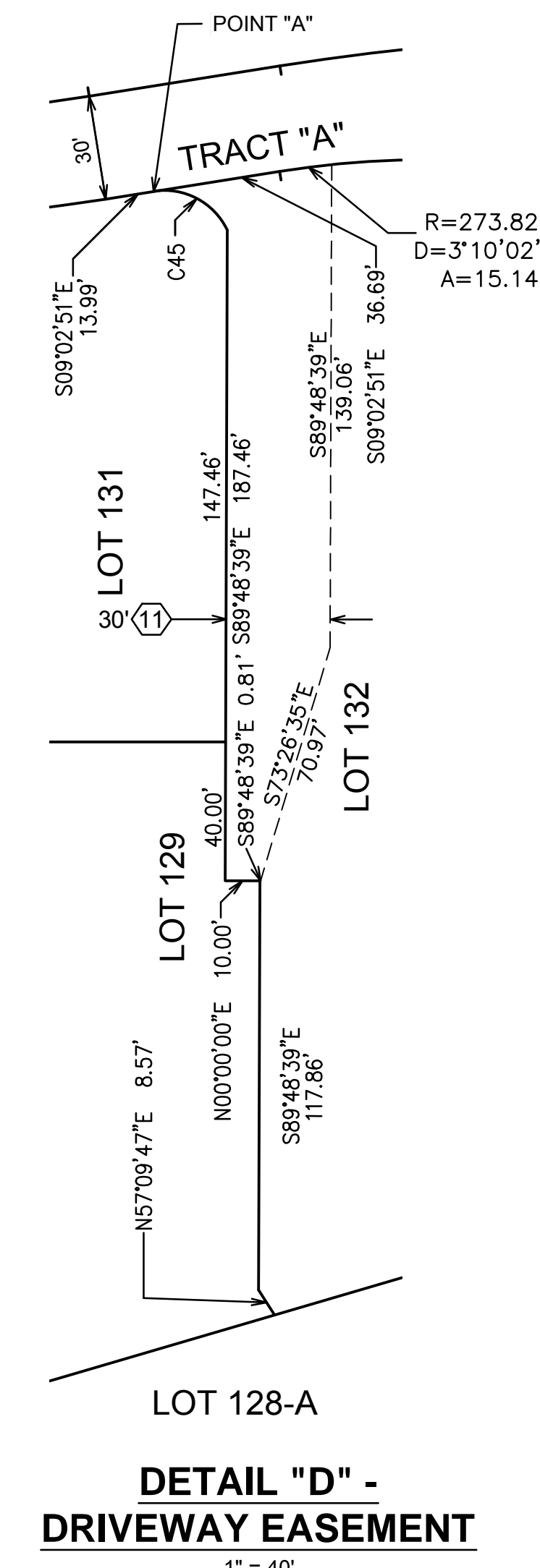
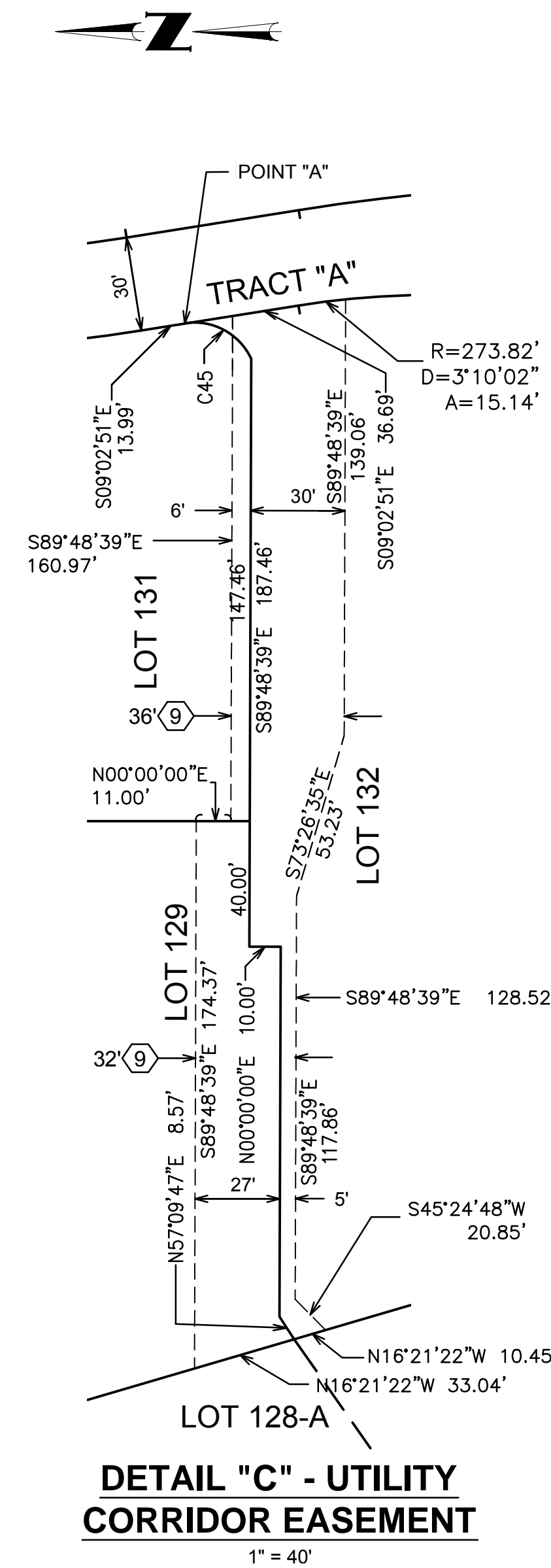
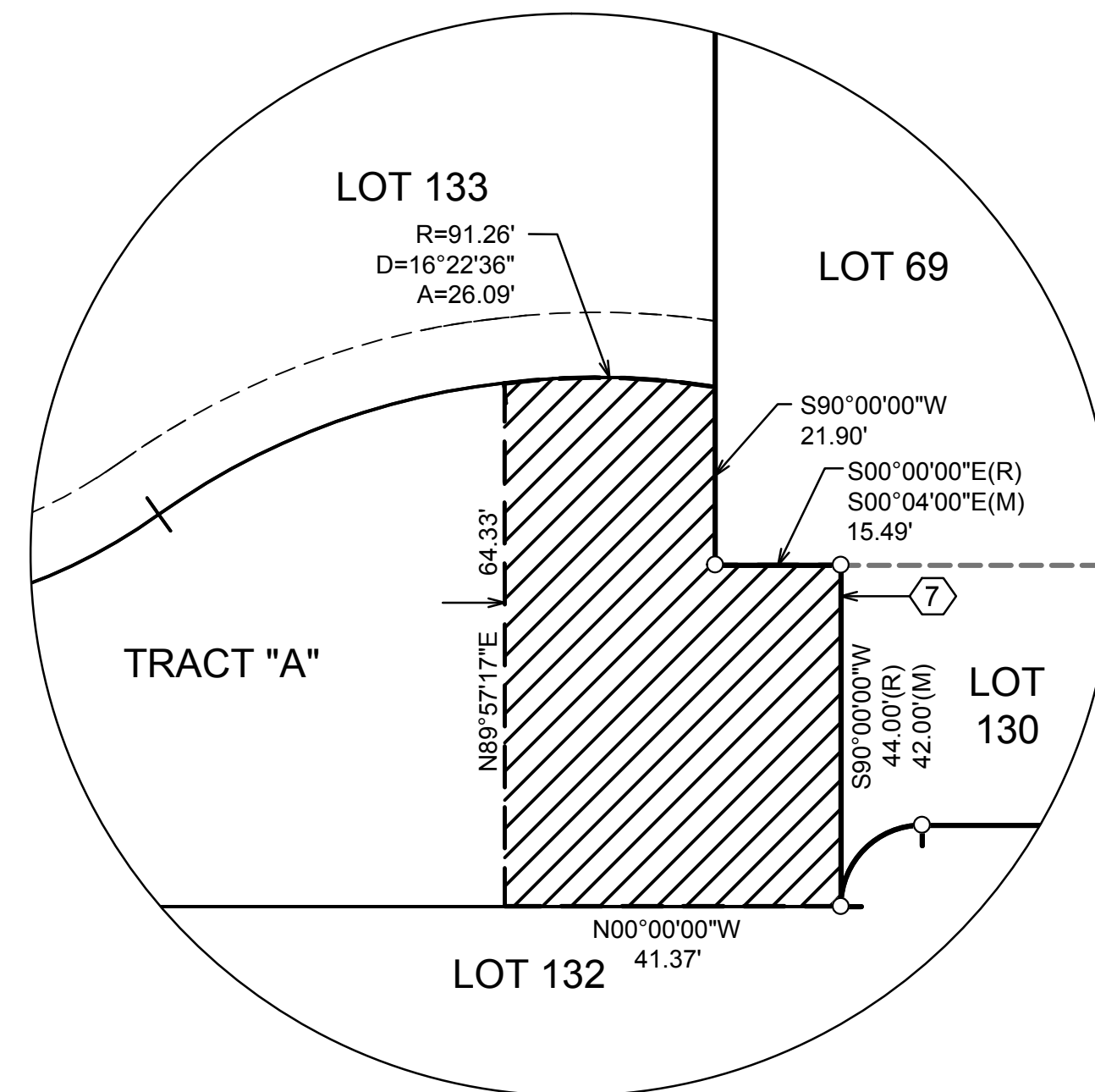
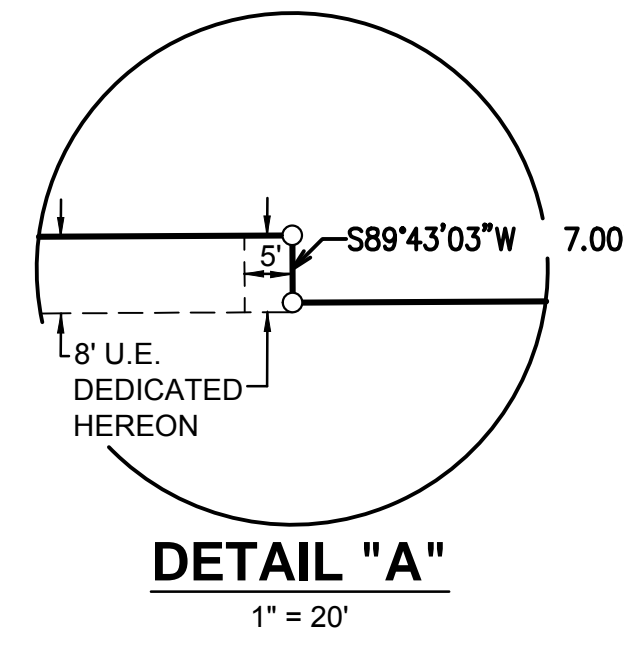

| NO. | REVISION | DATE |
|-----|----------|------|
|     |          |      |
|     |          |      |
|     |          |      |

**FINAL MAP**  
**MOUNTAIN SHADOW RESORT**  
**UNIT - 2 AMENDED VII**



N:\010245811\CADD\AMENDED VILDS\FPLAT.S01.DWG MikeR June 4, 2015 - 2:36 PM