

# PRELIMINARY MAP "THE VILLAS AT MOUNTAIN SHADOWS CONDOMINIUMS"

## NOTES

- THE BOUNDARIES OF EACH UNIT ARE AS FOLLOWS:  
(A) THE VERTICAL BOUNDARIES ARE THE INTERIOR FINISHED SURFACES OF THE PERIMETER WALLS OF THE UNIT;  
(B) THE LOWER HORIZONTAL BOUNDARY IS THE TOP SURFACE OF THE FLOOR SLAB BENEATH THE UNIT; AND  
(C) THE UPPER AND LOWER HORIZONTAL BOUNDARIES OF EACH UNIT SHALL BE FROM THE UNFINISHED FLOOR OF EACH UNIT TO THE UNFINISHED CEILING OF EACH UNIT.
- THE COMMON ELEMENTS OF THE VILLAS AT MOUNTAIN SHADOWS CONDOMINIUMS, A CONDOMINIUM, WILL CONSIST OF ALL THE PROPERTY WITHIN THE BOUNDARIES OF THE CONDOMINIUM AS SHOWN ON THIS CONDOMINIUM MAP, EXCEPT FOR THE UNITS.
- TIES SHOWN ARE TO OUTSIDE FACE OF BUILDINGS (GROUND LEVEL)
- EASEMENTS FOR THE PRIVATE DRIVES, PUBLIC AND PRIVATE UTILITIES, AND EMERGENCY AND SERVICE TYPE VEHICLES WILL BE PROVIDED WITH A MAP OF DEDICATION TO BE PROCESSED WITH THE FINAL MAP FOR "THE VILLAS AT MOUNTAIN SHADOWS CONDOMINIUMS".

A CONDOMINIUM UPON TRACT E OF "THE VILLAS AT MOUNTAIN SHADOWS II" AS RECORDED IN BOOK \_\_\_\_\_ OF MAPS AT PAGE \_\_\_ OF THE MARICOPA COUNTY RECORDERS OFFICE, AND SITUATED IN THE SE1/4 OF SECTION 8, T2N, R4E OF THE GILA AND SALT RIVER BASE AND MERIDIAN, MARICOPA COUNTY, ARIZONA

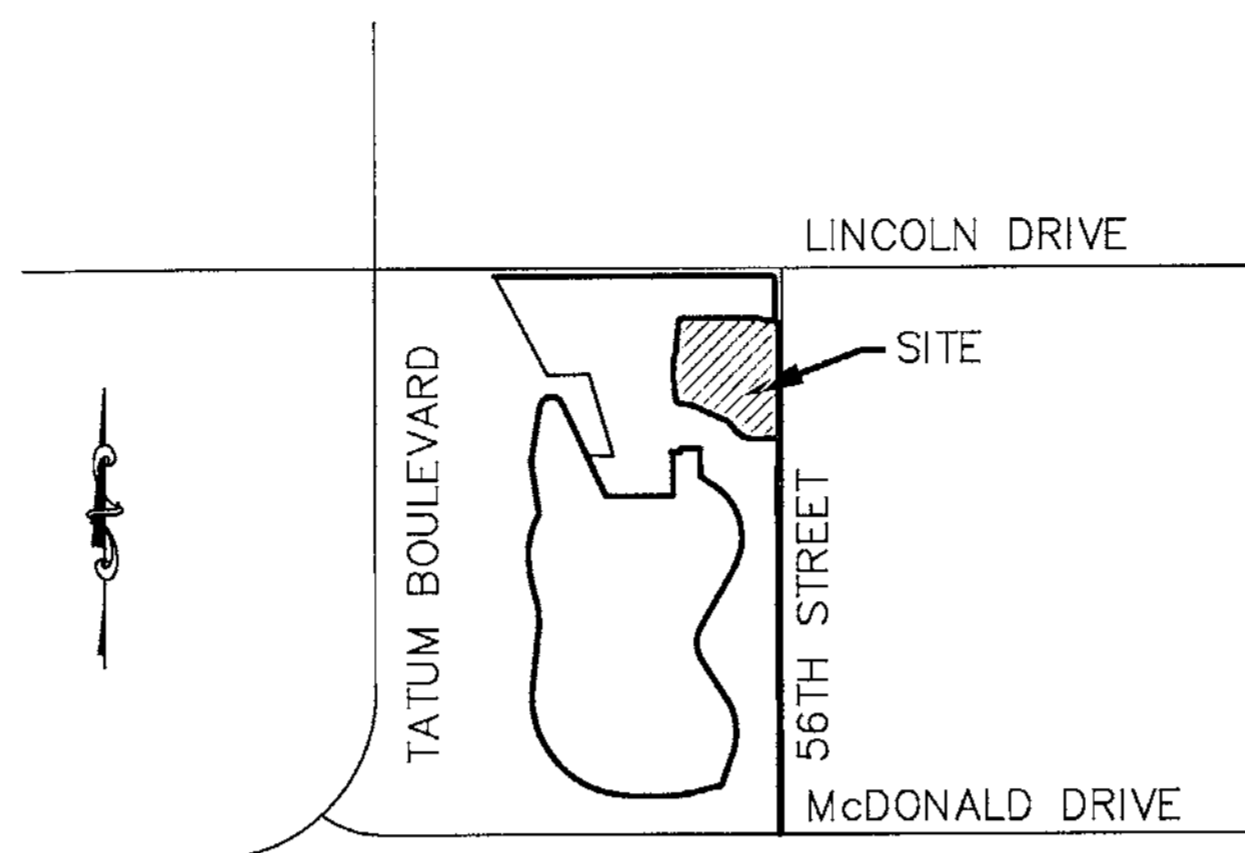

VICINITY MAP  
N.T.S.

## 100 YEAR ASSURED WATER SUPPLY

THE AREA PLATTED HEREON LIES WITHIN THE DOMESTIC WATER SERVICE AREA OF EPCOR WATER ARIZONA INC. - PARADISE VALLEY WHICH IS DESIGNATED AS HAVING AN ASSURED WATER SUPPLY PURSUANT TO SECTION 45-576 ARIZONA REVISED STATUTES AS PER ARIZONA DEPARTMENT OF WATER RESOURCES CERTIFICATE NUMBER \_\_\_\_\_ DATED \_\_\_\_\_

## DRAINAGE EASEMENT RESTRICTIONS

PURSUANT TO A.R.S. 9-463.01(C), AND ARTICLE 6-4(E)(J), 8-7-1 ET. SEQ., AND SECTION 6-3-8 OF THE CODE OF ORDINANCES OF THE TOWN OF PARADISE VALLEY, DRAINAGE EASEMENTS ARE FOR THE PURPOSE OF ALLOWING STORM, FLOOD AND OTHER WATERS TO PASS OVER, UNDER OR THROUGH THE LAND SET ASIDE FOR SUCH EASEMENTS, AND NOTHING WHICH MAY, TO ANY DEGREE, IMPEDE OR OBSTRUCT THE FLOW OF SUCH WATERS. SHALL BE CONSTRUCTED, PLACED, PLANTED, OR ALLOWED TO GROW ON OR IN SUCH EASEMENTS. THE MAINTENANCE AND CLEARING OF THESE DRAINAGE EASEMENTS SHALL BE THE SOLE RESPONSIBILITY AND DUTY OF THE OWNER OF THE PROPERTY ON WHICH SAID EASEMENTS ARE PLATTED. HOWEVER, THE TOWN OF PARADISE VALLEY, A MUNICIPAL CORPORATION, MAY, IF THE TOWN DEEMS IT TO BE IN THE BEST INTERESTS OF THE HEALTH, SAFETY, OR WELFARE OF THE TOWN OF PARADISE VALLEY, CONSTRUCT AND/OR MAINTAIN DRAINAGE FACILITIES ON OR UNDER SUCH EASEMENTS. AGENTS AND EMPLOYEES OF THE TOWN OF PARADISE VALLEY SHALL HAVE FREE ACCESS TO AND FROM ALL PORTIONS OF SUCH EASEMENTS AT ALL TIMES.

## UTILITY PROVIDERS

SEWER	CITY OF PHOENIX
WATER	EPCOR WATER
TELEPHONE	CENTURY LINK
CABLE	COX COMMUNICATIONS
GAS	SOUTHWEST GAS
ELECTRIC	ARIZONA PUBLIC SERVICE

## SITE DATA

EXISTING ZONING - S.U.P.- RESORT
TOTAL TRACTS - 1
TOTAL UNITS - 40
GROSS SITE AREA - 5.17 AC.
NET SITE AREA - 5.17 AC.

## LEGEND

BSL - BUILDING SETBACK LINE	G - GAS LINE
B/C - BACK OF CURB	S - SEWER LINE
C.A. - COMMON AREA	W - WATER LINE
E/P - EDGE OF PAVEMENT	△ - FND. OR SET MONUMENT AT SECTION CORNER
ESMT. - EASEMENT	⊙ - SUBDIVISION CORNER &/OR FND. OR SET MONUMENT AS NOTED
EXST. - EXISTING	⊕ - FIRE HYDRANT (EXISTING)
P.U.E. - PUBLIC UTILITY EASEMENT	⊕ - FIRE HYDRANT (PROPOSED)
U.E. - UTILITY EASEMENT	⊙ - SEWER MANHOLE (EXISTING OR PROPOSED)
TYP. - TYPICAL	TR - DENOTES TRUST
S.U.P.- SPECIAL USE PERMIT	MCR - DENOTES MARICOPA COUNTY RECORDS
M.A.G. - MARICOPA ASSOCIATION OF GOVERNMENTS	
STD. - STANDARD	
C - CABLE	
T - TELEPHONE	

## OWNER

MTS LAND, LLC, A DELEWARE LIMITED LIABILITY COMPANY  
4550 N. 12TH STREET  
PHOENIX, ARIZONA 85014  
PHONE: (602) 264-6831  
IRVINE, CA 92612  
PHONE: 949.476.2200  
CONTACT: ROBERT A. FLAXMAN, CEO

## BENCHMARK

W 1/4 CORNER OF SECTION 9, T.2.N., R.4.E.,  
FD BCHH ⊙ INTERSECTION OF 56TH STREET  
AND LINCOLN DRIVE.  
ELEVATION 1363.42 (NAVD 88' DATUM)

## ENGINEER

COE AND VAN LOO II L.L.C.  
4550 N. 12TH STREET  
PHOENIX, ARIZONA 85014  
PHONE: (602) 264-6831  
FAX: (602) 264-0928  
CONTACT: FRED E. FLEET P.E.  
EMAIL: FEF\_@CVLCI.COM

## SHEET INDEX

- DECLARATION & NOTES
- BOUNDARY MAP
- GROUND (1ST) LEVEL PLAN
- SECOND (2ND) LEVEL PLAN
- UNIT PLANS & VERTICAL SCHEMATIC
- PARKING PLAN

## MTS LAND LLC, A DELEWARE LIMITED LIABILITY COMPANY IN WITNESS WHEREOF:

MTS LAND, LLC, A DELAWARE LIMITED LIABILITY COMPANY, AS OWNER, HAS HEREUNTO CAUSED IT'S NAME TO BE AFFIXED HERETO AND THE SAME TO BE ATTESTED BY ROBERT A. FLAXMAN IT'S AUTHORIZED AGENT.

ROBERT A. FLAXMAN, AUTHORIZED AGENT DATE \_\_\_\_\_

## ACKNOWLEDGMENT:

STATE OF CALIFORNIA }  
COUNTY OF ORANGE } SS

ON \_\_\_\_\_, BEFORE ME, ANN M. VERA, A NOTARY PUBLIC, PERSONALLY APPEARED ROBERT A. FLAXMAN, WHO PROVED TO ME ON THE BASIS OF SATISFACTORY EVIDENCE TO BE THE PERSON WHOSE NAME IS SUBSCRIBED TO THE WITHIN INSTRUMENT AND ACKNOWLEDGED TO ME THAT HE EXECUTED THE SAME IN HIS AUTHORIZED CAPACITY, AND THAT BY HIS SIGNATURE ON THE INSTRUMENT THE PERSON, OR THE ENTITY UPON BEHALF OF WHICH THE PERSON ACTED, EXECUTED THE INSTRUMENT.

I CERTIFY UNDER PENALTY OF PERJURY UNDER THE LAWS OF THE STATE OF CALIFORNIA THAT THE FOREGOING PARAGRAPH IS TRUE AND CORRECT.

WITNESS MY HAND AND OFFICIAL SEAL

SIGNATURE: \_\_\_\_\_  
ANN M. VERA

## APPROVALS:

APPROVED BY THE TOWN COUNCIL OF THE TOWN OF PARADISE VALLEY THIS \_\_\_\_\_ DAY \_\_\_\_\_, 2015.

BY: \_\_\_\_\_  
MAYOR

ATTEST: \_\_\_\_\_  
TOWN CLERK

\_\_\_\_\_

\_\_\_\_\_

## CERTIFICATION

THIS IS TO CERTIFY THAT THE SURVEY OF THE PREMISES DESCRIBED AND MAPPED HEREON WAS MADE UNDER MY DIRECTION DURING THE MONTH OF OCTOBER 2015 AND THAT THIS SURVEY IS COMPLETE AS SHOWN, THAT THE MONUMENTS SHOWN ACTUALLY EXIST, THAT THEIR POSITIONS ARE CORRECTLY SHOWN, AND THAT SAID MONUMENTS ARE SUFFICIENT TO ENABLE THE SURVEY TO BE RETRACED.

REGISTERED LAND SURVEYOR

NO.	REVISION	DATE

**PRELIMINARY MAP**  
 THE VILLAS AT MOUNTAIN SHADOWS CONDOMINIUMS  
 PARADISE VALLEY, ARIZONA

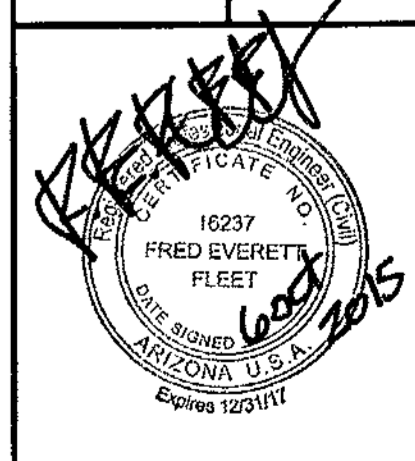

SHEET NUMBER  
1 OF 6



CVL Department: Land  
CVL Project #: 01-0245801  
CVL File: \_\_\_\_\_

# PRELIMINARY MAP "THE VILLAS AT MOUNTAIN SHADOWS CONDOMINIUMS"

A CONDOMINIUM UPON TRACT E OF "THE VILLAS AT MOUNTAIN SHADOWS II" AS RECORDED IN BOOK \_\_\_\_\_ OF MAPS AT PAGE \_\_\_ OF THE MARICOPA COUNTY RECORDERS OFFICE, AND SITUATED IN THE SE1/4 OF SECTION 8, T2N, R4E OF THE GILA AND SALT RIVER BASE AND MERIDIAN, MARICOPA COUNTY, ARIZONA

## BOUNDARY MAP

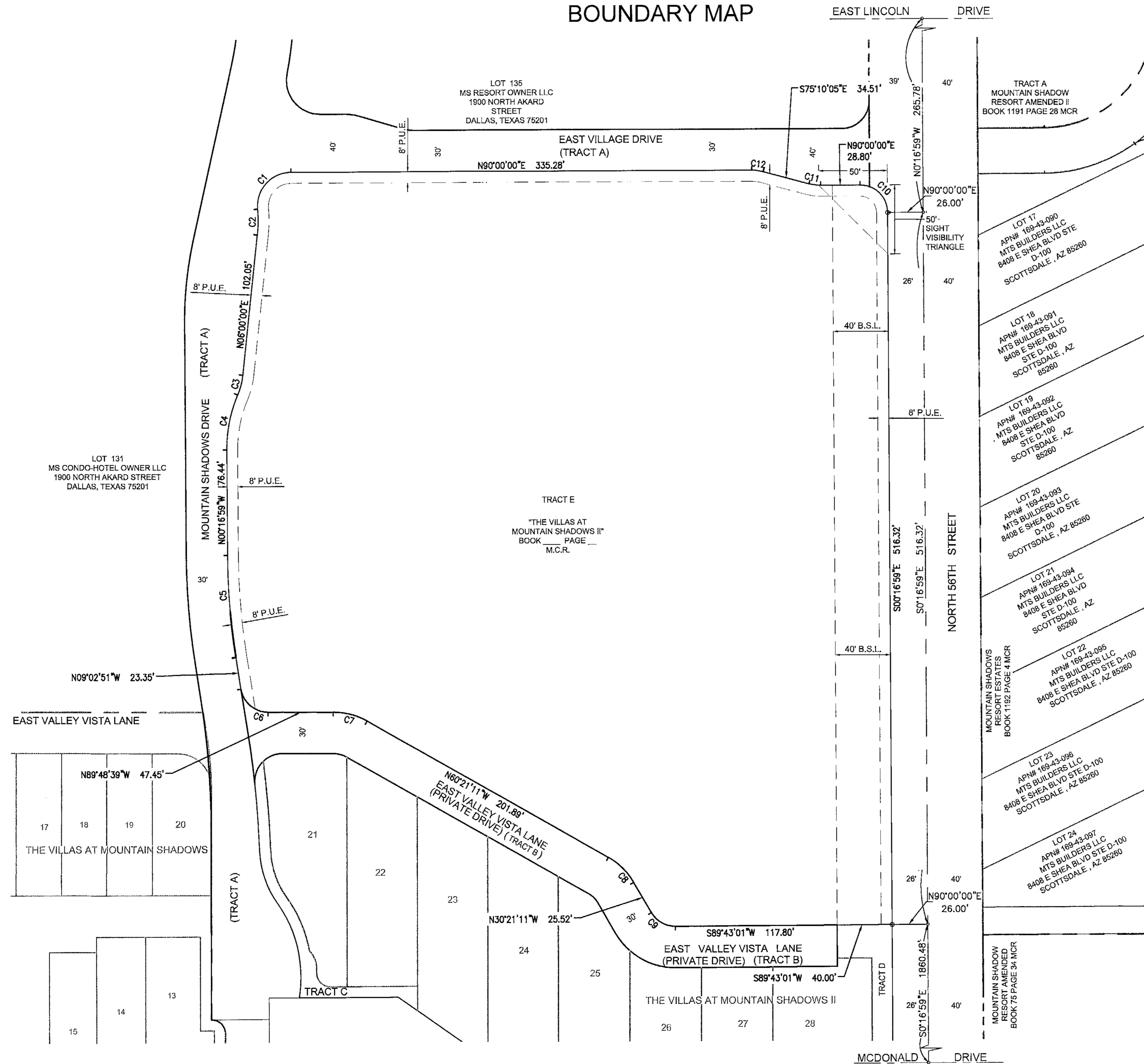

CURVE TABLE						
NO.	ARC	RADIUS	DELTA	TANGENT	CHORD	CHORD-BEARING
C1	40.53	24.50	094°47'15"	26.64	36.07	N42°36'23"E
C2	18.83	100.00	010°47'15"	9.44	18.80	N00°36'23"E
C3	14.97	50.00	017°09'27"	7.54	14.92	N14°34'44"E
C4	40.91	100.00	023°26'26"	20.75	40.63	N11°26'14"E
C5	74.19	485.00	008°45'52"	37.17	74.12	N04°39'55"W
C6	28.19	20.00	080°45'48"	17.01	25.92	N49°25'45"W
C7	25.71	50.00	029°27'28"	13.14	25.42	N75°04'55"W
C8	26.18	50.00	030°00'00"	13.40	25.88	N45°21'11"W
C9	20.92	20.00	059°55'48"	11.53	19.98	N60°19'05"W
C10	31.32	20.00	089°43'01"	19.90	28.21	S45°08'29"E
C11	8.41	32.50	014°49'55"	4.23	8.39	S82°35'02"E
C12	8.41	32.50	014°49'55"	4.23	8.39	S82°35'02"E

NO.	REVISION	DATE

**PRELIMINARY MAP**  
THE VILLAS AT MOUNTAIN SHADOWS CONDOMINIUMS  
PARADISE VALLEY, ARIZONA



SHEET NUMBER  
**2 OF 6**

CVL Department, Land  
CVL Project #: 01-0245801  
CVL File:

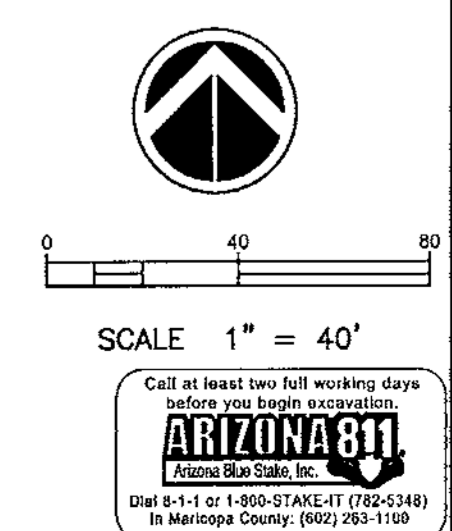

Print Date: October 6, 2015 File Name: N:\010245801\CAD\DWG\EST\Condo\preliminary\PS.PRE.CONDO.MAP.01-05.093015.dwg

**CVL CONSULTANTS**  
4550 North 12th Street  
Phoenix, Arizona 85014  
602-264-6831  
www.cvlci.com

**Coe and Van Loo II L.L.C.**

PROJECT NO. XXXXXX

# PRELIMINARY MAP

## "THE VILLAS AT MOUNTAIN SHADOWS CONDOMINIUMS"

A CONDOMINIUM UPON TRACT E OF "THE VILLAS AT MOUNTAIN SHADOWS II" AS RECORDED IN BOOK \_\_\_\_\_ OF MAPS AT PAGE \_\_\_\_\_ OF THE MARICOPA COUNTY RECORDERS OFFICE, AND SITUATED IN THE SE1/4 OF SECTION 8, T2N, R4E OF THE GILA AND SALT RIVER BASE AND MERIDIAN, MARICOPA COUNTY, ARIZONA

### GROUND (1ST) LEVEL PLAN

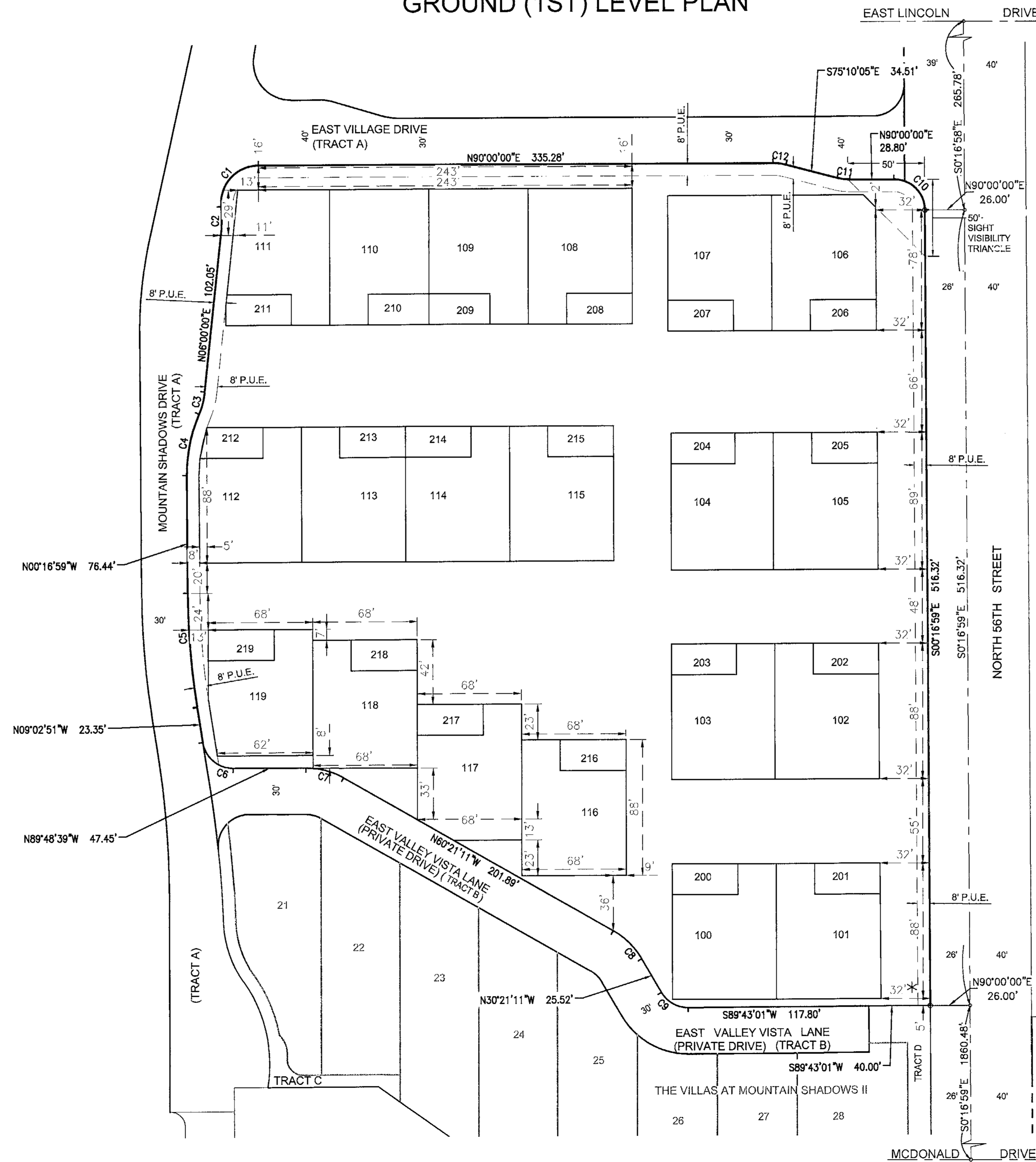

\* DENOTES SET BACK FROM PROPERTY LINE TO LIMITS OF PATIO AND OR BALCONY AIR SPACE



SCALE 1" = 40'



NO.	REVISION	DATE

**PRELIMINARY MAP**

THE VILLAS AT MOUNTAIN SHADOWS CONDOMINIUMS  
PARADISE VALLEY, ARIZONA

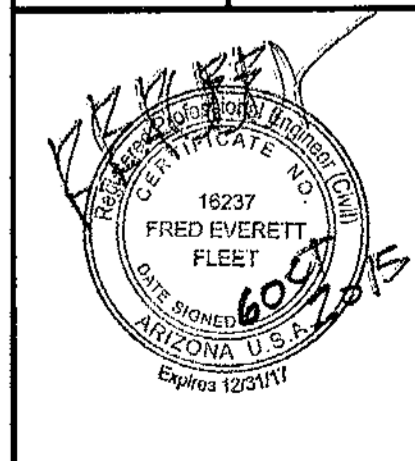

SHEET NUMBER  
**3 OF 6**

CIVL Department: Land  
CIVL Project #: 01-0245501  
CIVL File:

**CVL**  
CONSULTANTS

4550 North 12th Street  
Phoenix, Arizona 85014  
602-264-6831  
www.cvlci.com

**Coe and Van Loo II L.L.C.**

PROJECT NO. XXXXXXX

# PRELIMINARY MAP

## "THE VILLAS AT MOUNTAIN SHADOWS CONDOMINIUMS"

A CONDOMINIUM UPON TRACT E OF "THE VILLAS AT MOUNTAIN SHADOWS II" AS RECORDED IN BOOK \_\_\_\_\_ OF MAPS AT PAGE \_\_\_\_ OF THE MARICOPA COUNTY RECORDERS OFFICE, AND SITUATED IN THE SE1/4 OF SECTION 8, T2N, R4E OF THE GILA AND SALT RIVER BASE AND MERIDIAN, MARICOPA COUNTY, ARIZONA

### SECOND (2ND) LEVEL PLAN

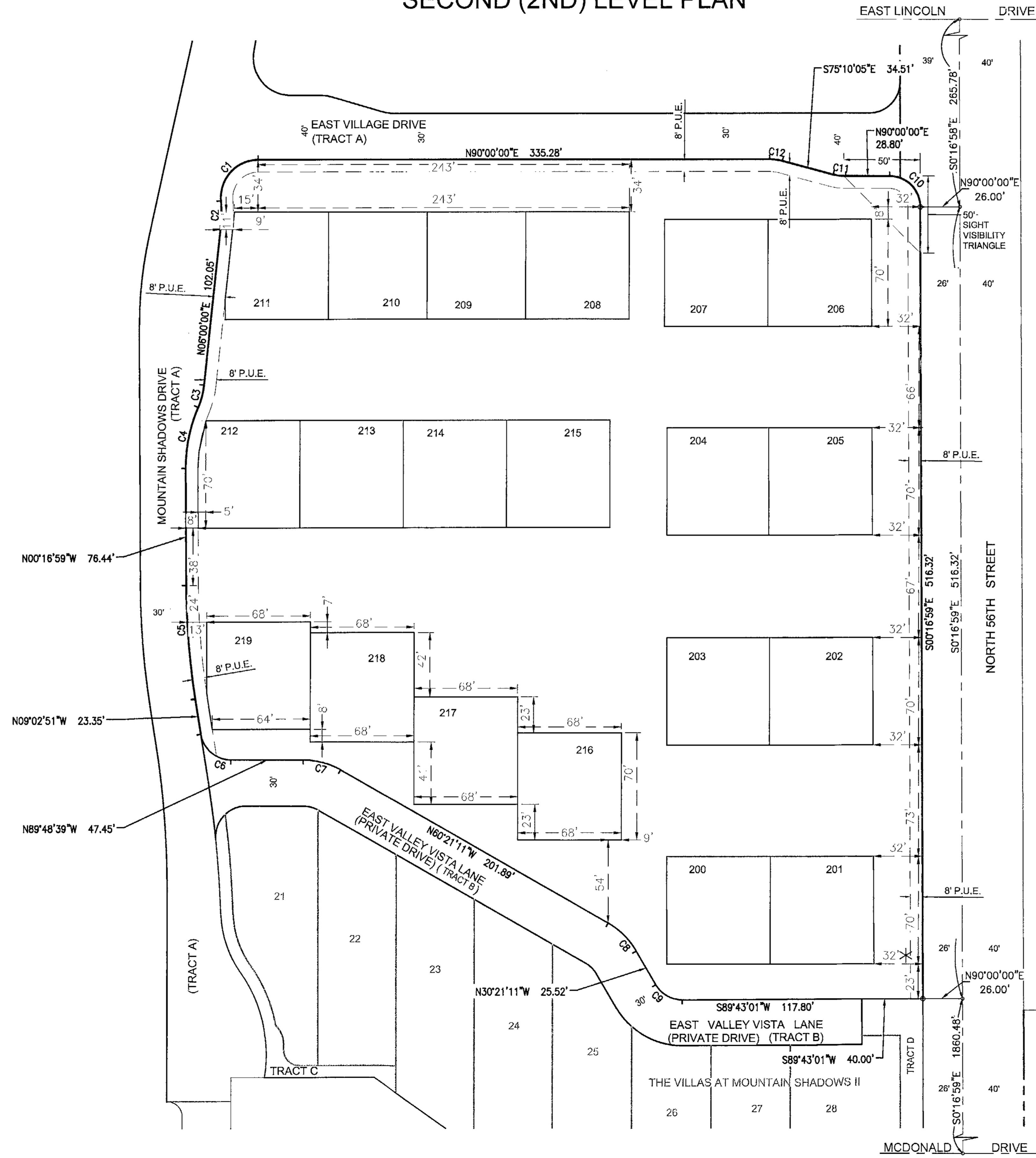

\* DENOTES SET BACK FROM PROPERTY LINE TO LIMITS OF PATIO AND OR BALCONY AIR SPACE

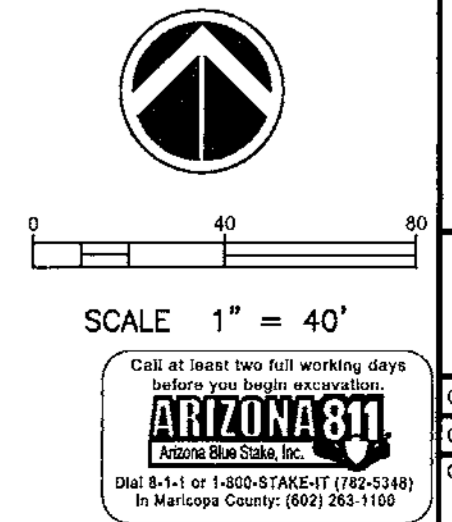

NO.	REVISION	DATE

**PRELIMINARY MAP**

THE VILLAS AT MOUNTAIN SHADOWS CONDOMINIUMS  
PARADISE VALLEY, ARIZONA



SHEET NUMBER  
**4 OF 6**

CVL Department: Land  
CVL Project #: 01-0245901  
CVL File:

**CVL**  
CONSULTANTS  
4550 North 12th Street  
Phoenix, Arizona 85014  
602-264-8831  
www.cvlci.com

**Coe and Van Loo II L.L.C.**



PRELIMINARY MAP  
**"THE VILLAS AT MOUNTAIN SHADOWS CONDOMINIUMS"**

A CONDOMINIUM UPON TRACT E OF "THE VILLAS AT MOUNTAIN SHADOWS II" AS RECORDED IN BOOK \_\_\_\_\_ OF MAPS AT PAGE \_\_\_ OF THE MARICOPA COUNTY RECORDERS OFFICE, AND SITUATED IN THE SE1/4 OF SECTION 8, T2N, R4E OF THE GILA AND SALT RIVER BASE AND MERIDIAN, MARICOPA COUNTY, ARIZONA

**UNIT PLANS & VERTICAL SCHEMATIC**

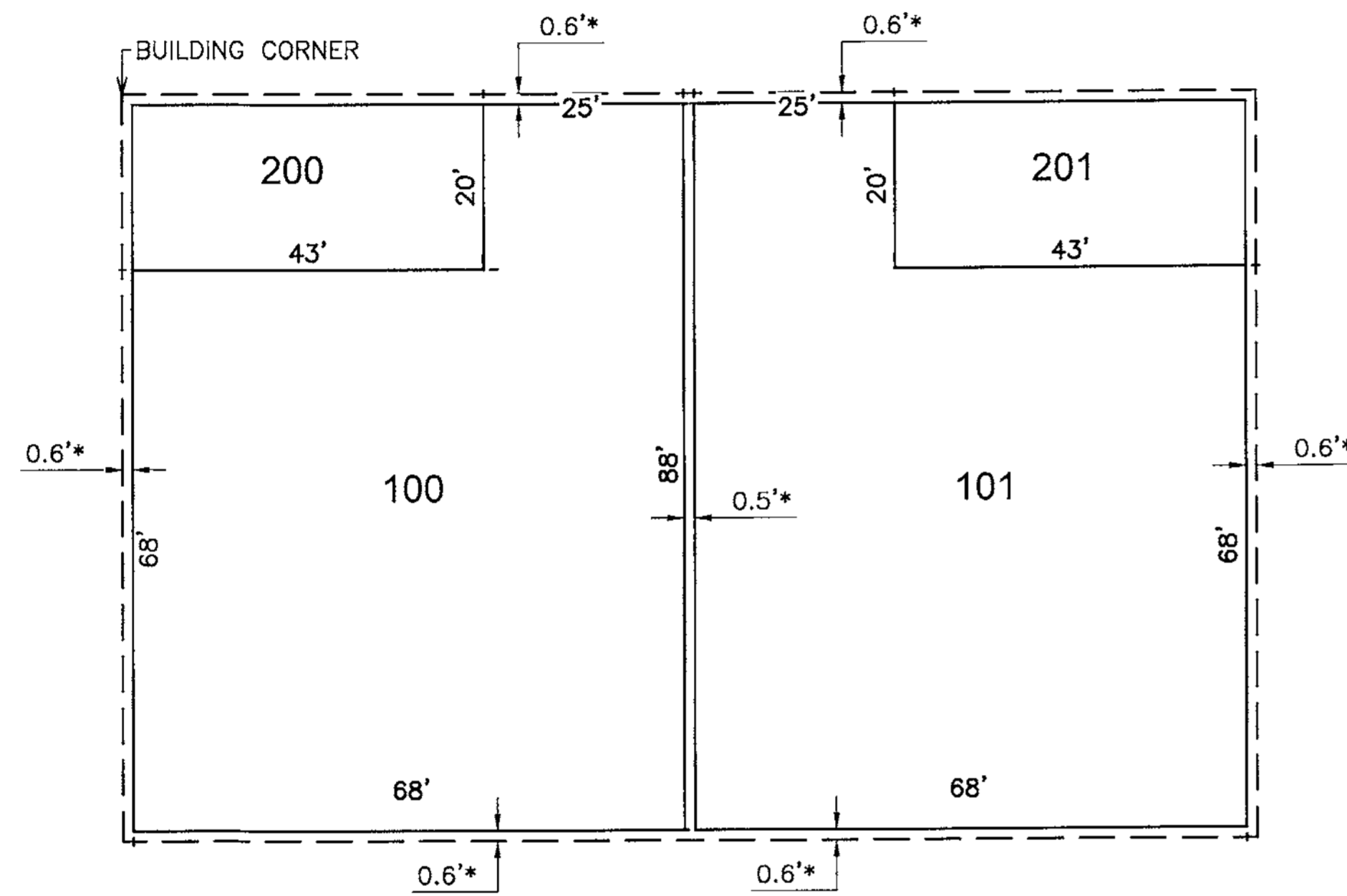

TYPICAL FIRST LEVEL PLAN  
 N.T.S.

UNIT NUMBER	LOWER UNIT BOUNDARY	UPPER UNIT BOUNDARY
100		
101		
102		
103		
104		
105		
106		
107		
108		
109		
110		
111		
112		
113		
114		
115		
116		
117		
118		
119		

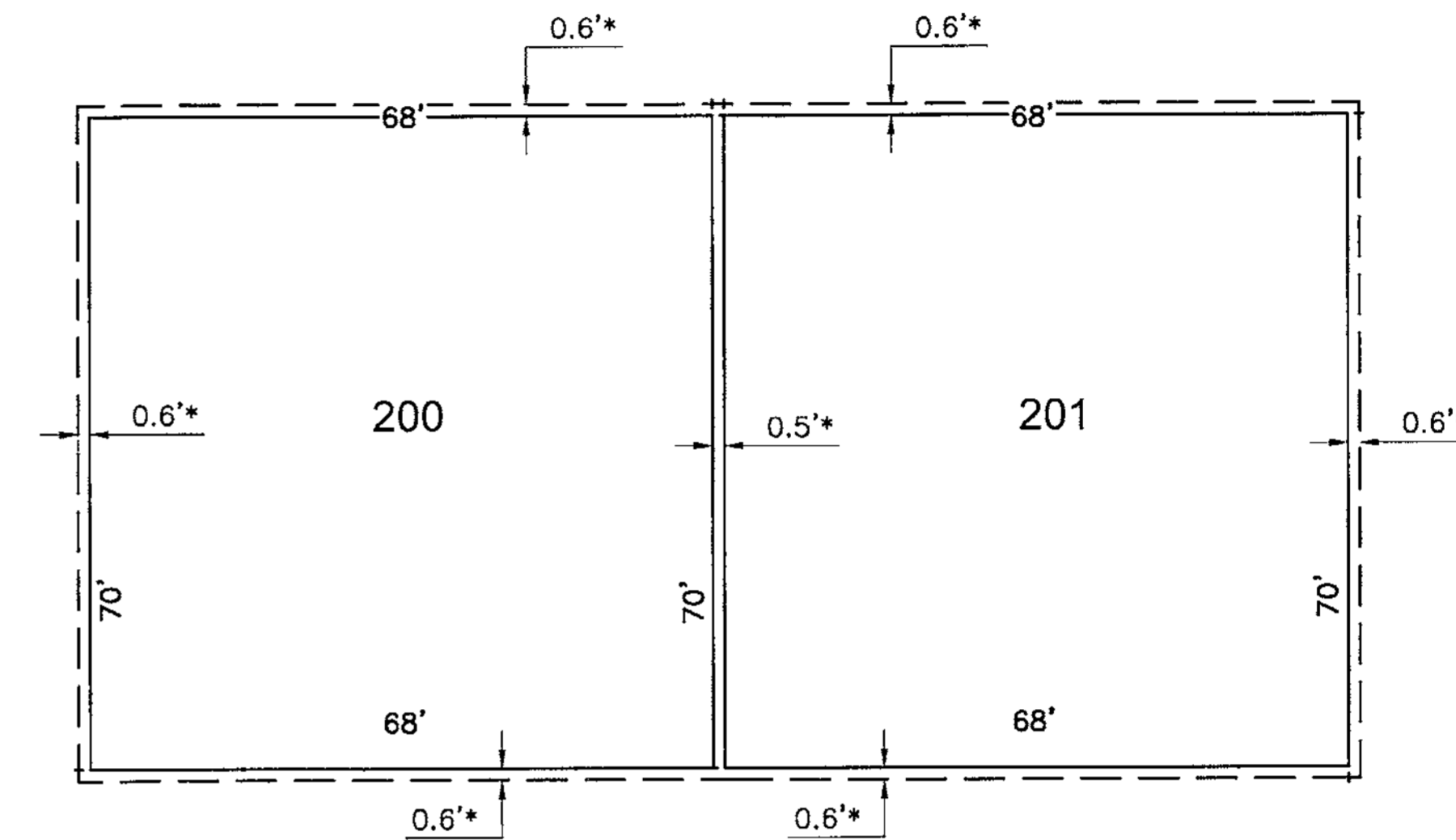

TYPICAL SECOND LEVEL PLAN  
 N.T.S.

UNIT NUMBER	LOWER UNIT BOUNDARY	UPPER UNIT BOUNDARY
200		
201		
202		
203		
204		
205		
206		
207		
208		
209		
210		
211		
212		
213		
214		
215		
216		
217		
218		
219		

**LEGEND**

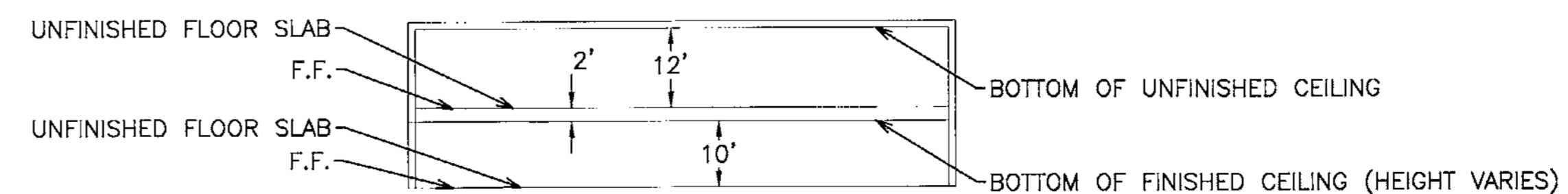

- INTERIOR BOUNDARY
- - - EXTERIOR FACE / COMMON WALL
- F.F. — FINISHED FLOOR
- 0.5'\* — COMMON / INTERIOR WALL DIMENSION
- 0.6'\* — COMMON / EXTERIOR WALL DIMENSION



VERTICAL SCHEMATIC  
 N.T.S.





-  = BUILDING LIMITS
-  = DRIVEWAY
-  = EMERGENCY ACCESS

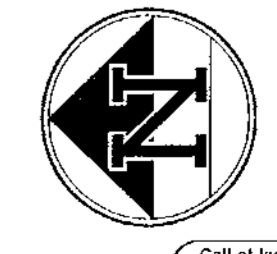

NO.	REVISION	DATE

**PRELIMINARY MAP**

THE VILLAS AT MOUNTAIN SHADOWS CONDOMINIUMS  
PARADISE VALLEY, ARIZONA

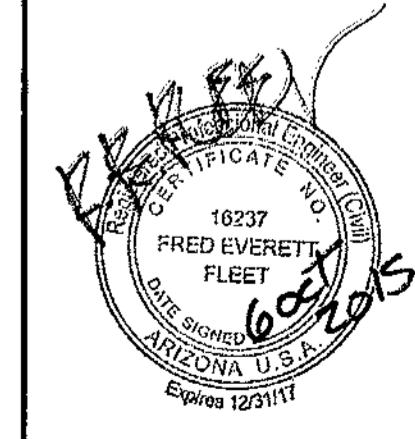

SHEET NUMBER  
**6 OF 6**

CVL Department: Land  
CVL Project #: 01-0245901  
CVL File:

**Coe and Van Loo II L.L.C.**